

## KA8603

## UNIVERSAL SPEECH NETWORK

### INTRODUCTION

The KA8603 can fulfill the standards of other countries by changing the external component. Dynamic or piezoelectric type can be used with receiver. Each gain is controlled with AGC in accordance with the line current. The KA8603 can be operated down to D.C line 1.6V.

### FEATURES

- Independent adjustment of DC resistance and AC impedance.
- ECM or dynamic microphone can be used.
- DTMF signal interface.
- Mute function
- Operates at the low line voltage (1.6V)
- Low or high impedance receiver type can be used.
- Low line current operation. (IL = 4mA)

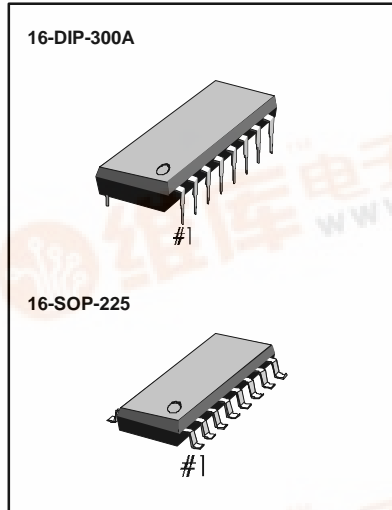

### ORDERING INFORMATION

Device	Package	Operating Temperature
KA8603	16-DIP-300A	- 25°C ~ + 75°C
KA8603D	16-SOP-225	

### BLOCK DIAGRAM

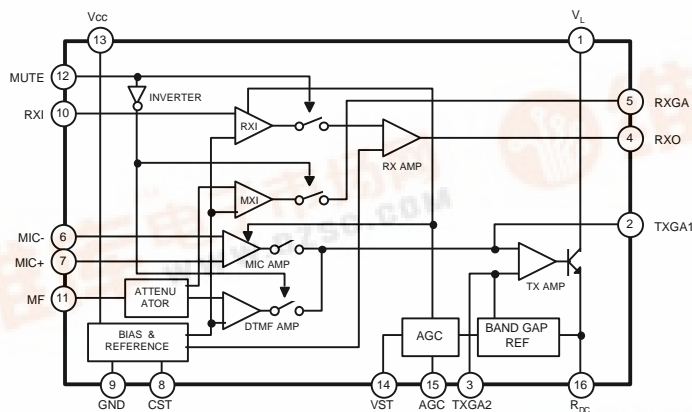

**SAMSUNG**

**ELECTRONICS**

## PIN CONFIGURATION

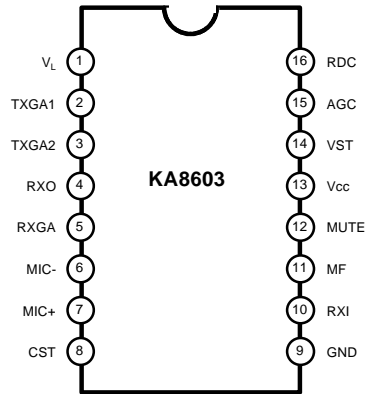

## PIN DESCRIPTION

Pin No	Symbol	Description
1	V <sub>L</sub>	Positive power line and TX Amp output
2	TXGA1	TX gain adjustment
3	TXGA2	TX gain adjustment
4	RXO	RX output
5	RXGA	RX gain adjustment
6	MIC-	Mic(-) input
7	MIC+	Mic(+) input
8	CST	Current stabilizer
9	GND	Ground
10	RXI	RX input
11	MF	DTMF Input
12	MUTE	Mute 'High' : DTMF mode, Mute 'Low' : speech mode
13	V <sub>CC</sub>	Internal power supply pin
14	VST	Voltage stabilizer
15	AGC	Automatic gain control
16	R <sub>DC</sub>	DC Resistance control

## ABSOLUTE MAXIMUM RATINGS

Characteristic	Symbol	Value	Unit
Line Voltage	$V_L$	15	V
Line Current	$I_L$	150	mA
Surge Line Current	$I_{L(SURGE)}$	200	mA
Power Dissipation	$P_D$	1.0	W
Operating Temperature	$T_{ORP}$	- 25 ~ 75	°C
Storage Temperature	$T_{STG}$	- 55 ~ 150	°C

## ELECTRICAL CHARACTERISTICS

(Ta = 25°C, f = 1KHz,  $I_L$  = 15mA, unless otherwise noted)

Characteristic	Symbol	Test Conditions	Min	Typ	Max	Unit	
Line Voltage	$V_L$	$I_L = 4mA$ $I_L = 15mA$ $I_L = 50mA$ $I_L = 140mA$	-	2.1	-	V	
			3.55	3.9	4.25		
			4.1	4.6	5.1		
			-	6.45	7.0		
Line Voltage with $R_{UP}$	$V_{LU}$	Between Pin14 & Pin 16 $R_{UP} = 220K\Omega$	4.15	4.35	4.55	V	
Line Voltage with $R_{DOWN}$	$V_{LD}$	Between Pin 14& Pin 1 $R_{DOWN} = 330K\Omega$	3.25	3.45	3.65	V	
TX Gain	$G_{V(TX)}$	$R_{TX} = 68 K\Omega$ $V_i = 3mV_{rms}$	$I_L = 15mA$	49.5	51.5	53.5	dB
			$I_L = 50mA$	45.5	47.5	49.5	
			$I_L = 80mA$	43.5	45.5	47.5	
TX Gain frequency response	$\Delta G_{TXF}$	f = 300 to 3400Hz	-	$\pm 0.2$	-	dB	
TX Dynamic output voltage	$V_{O(TX)}$	THD = 2% THD = 10%	-	1.6	-	Vrms	
			1.7	2.2	-		
MIC Input Impedance	$Z_{I(MIC)}$	-	-	64	-	K $\Omega$	
RX Gain	$G_{V(RX)}$	$R_{LOAD} = 150\Omega + 10\mu$	$I_L = 15mA$	28.5	30.5	32.5	dB
			$I_L = 50mA$	24.5	26.5	28.5	
			$I_L = 80mA$	22.5	24.5	26.5	
RX Gain frequency response	$\Delta G_{RXF}$	f = 300 to 3400Hz	-	$\pm 0.2$	-	dB	
RX Dynamic output voltage	$V_{O(RX)}$	THD = 2% ( $R_L = 150\Omega$ ) THD = 10%	0.22	0.29	-	Vrms	
			0.30	0.40	-		

**ELECTRICAL CHARACTERISTICS**(Ta = 25°C, f = 1KHz, I<sub>L</sub> = 15mA, unless otherwise noted)

Characteristic	Symbol	Test Conditions	Min	Typ	Max	Unit
DTMF GAIN	G <sub>V(MF)</sub>	R <sub>TX</sub> = 68KΩ (MUTE = H)	23.5	25.5	27.5	dB
DTMF Input Impedance	Z <sub>I(MF)</sub>	-	-	20.7	-	KΩ
MUTE Input Voltage	V <sub>IH(MUTE)</sub>	-	1.5	-	V <sub>CC</sub>	V
	V <sub>IL(MUTE)</sub>	-	-	-	0.8	
TX Gain variation range by AGC	ΔG <sub>TXA</sub>	R <sub>AGC</sub> = 180KΩ I <sub>L</sub> = 15 ~ 80mA	-	-6	-	dB
RX Gain variation range by AGC	ΔG <sub>RXA</sub>	R <sub>AGC</sub> = 180KΩ I <sub>L</sub> = 15 ~ 80mA	-	-6	-	dB
TX Noise Output Voltage (Psophometric weighted)	V <sub>TNO</sub>	-	-	-72	-	dBmp
RX Noise Output Voltage (Psophometric weighted)	V <sub>RNO</sub>	-	-	50	-	uV

KA8603

UNIVERSAL SPEECH NETWORK

APPLICATION CIRCUIT

