

## KA9220C

## RF AMP + SSP

### INTRODUCTION

The KA9220C is an 1-Chip BICMOS integrated circuit to perform the function of RF AMP and SSP (Servo Signal Processor) for Compact disc player applications. It consists of RF signal processing, focus servo, tracking servo, sled servo control, EFM detecting and automatic power control circuits.

### FEATURES

- RF Amplifier
- Focus Error Amplifier
- Tracking Error Amplifier
- Mirror Detector
- Focus OK detector
- EFM Comparator and Auto-Asymmetry control Amplifier
- Defect Detector for improvement to playability
- Built-in APC (Automatic power control) Amplifier (Focus, Tracking, sled, spindle servo control)
- Built-in Autosequencer
- Anti-shock function
- The function of preventing sled run away
- Double speed operation available
- Operating supply Voltage range: 3.4 ~ 5.5V

80 - QFP - 1420C

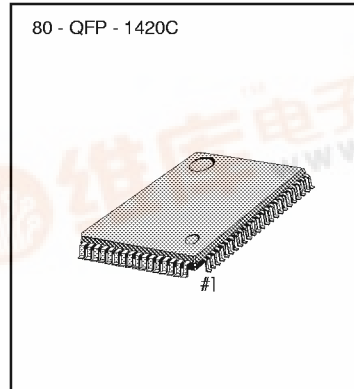

### ORDERING INFORMATION

Device	Package	Operating Temperature
KA9220C	80-QFP-1420C	-20°C~ +75°C

**SAMSUNG**

**ELECTRONICS**

BLOCK DIAGRAM

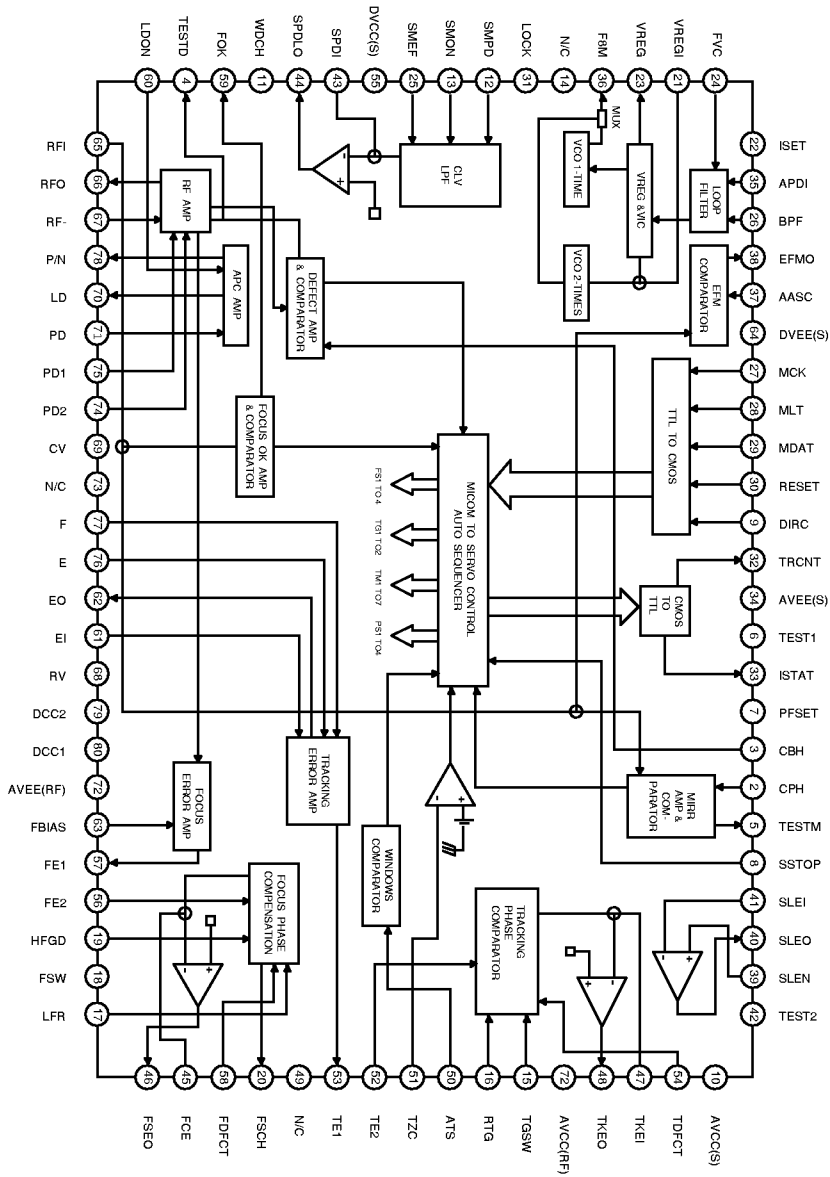

Fig. 1

## PIN DESCRIPTION

Pin No	Symbol	Description
1	AVEE (R)	Analog negative power supply input pin for RF part
2	CPH	Capacitor connection pin of mirror hold.
3	CBH	Capacitor connection pin of defect bottom-hold
4	TESTD	Defect test pin
5	TESTM	Mirror test pin
6	Test1	Input pin for test
7	PPSET	Peak frequency setting pin for focus, tracking compensation and fc (cut off frequency) of CLV LPF.
8	SSTOP	Check the position pin of pick-up whether inside or not.
9	DIRC	Direct 1 Track Jump Control Pin
10	AVCC (S)	Analog positive power supply input pin for SERVO part.
11	WDCH	Auto-sequencer clock-input pin (Normal speed = 88.2KHz, Double speed = 176.4KHz)
12	SMPD	Connection pin of DSP SMPD
13	SMON	Connection pin of DSP SMON, spindle servo ON at "H"
14	N/C	No connection pin
15	TGSW	Providing time constant to change the high frequency tracking gain
16	RTG	Capacitor connection pin to switch the tracking gain of high frequency
17	LFR	Capacitor connection pin to perform rising low bandwidth of focus servo loop
18	FSW	High frequency gain of focus servo loop can be changed by FS3 switch ON or OFF
19	HFGD	Reducing high frequency gain with capacitor connected between pini18 and pin19
20	FSCH	Time constant external pin to generate focus search waveform
21	VREGI	External regulator voltage input pin for VCO
22	ISET	Determining the peak value of focus search, track jump and SLED kick

## PIN DESCRIPTION (CONTINUED)

Pin No	System	Description
23	VREG	3.5V Regulator output pin
24	N/C	No connection pin
25	SMEF	Providing an external LPF time constant of CLV SERVO Loop
26	N/C	No connection Pin
27	MCK	Clock input pin from micom
28	MLT	Latch input pin from micom
29	MDAT	Data input pin from micom
30	RESET	Reset input pin from micom, reset at "L"
31	LOCK	Pin for operation of the sled runaway prevention function at "L"
32	TRCNT	Track count output pin
33	ISTAT	Internal status output pin
34	AVEE (S)	Analog negative power supply input pin for SERVO part
35	N/C	No connection
36	N/C	No connection
37	AASC	Auto-Asymmetry control input pin
38	EFMO	EFM comparator output pin
39	SLEN	Non-inverting input pin of SLED SERVO amplifier
40	SLEO	Output pin of SLED SERVO amplifier
41	SLEI	Inverting input pin of SLED SERVO amplifier
42	TEST2	Test input pin to change speed mode Normal speed = "H", Double speed = "L"
43	SPDI	Inverting input pin of spindle servo amplifier
44	SPDLO	Spindle servo amplifier output pin
45	FCE	Inverting input pin of focus servo amplifier.

## PIN DESCRIPTION (Continued)

Pin No	System	Description
46	FSEO	Output pin of focus servo amplifier
47	TKEI	Non-inverting input pin of tracking servo amplifier
48	TKEO	Output pin of tracking servo amplifier
49	N/C	No connection
50	ATS	Anti-shock input pin
51	TZC	Tracking Zero Crossing input pin
52	TE2	Tracking Error Servo input pin
53	TE1	Output pin of tracking Error Amplifier
54	TDFCT	Capacitor Connection pin for Defect Compensation of tracking servo
55	DVCC (S)	Digital positive power supply input pin for servo part
56	FE2	Focus error servo input pin
57	FE1	Output pin of focus error Amplifier
58	FDFCT	Capacitor connection pin for defect compensation of focus servo
59	FOK	Output pin of Focus OK comparator.
60	LDON	Laser diode ON/OFF control pin
61	EI	Feedback input pin of E I-V amplifier
62	EO	Output pin of E I-V Amplifier
63	FBIAS	Bias pin of non-inverting input of focus error amplifier
64	DVEE (S)	Digital negative power supply input pin for servo part
65	RFI	Output Signal of RF summing amplifier is inputted through capacitor
66	RFO	Output pin of RF summing amplifier
67	RF-	Inverting input pin of RF summing amplifier
68	RV	Output pin of $(AVCC + AVEE)/2$ Voltage
69	CV	Bias input pin of Center Voltage buffer

## PIN DESCRIPTION (CONTINUED)

Pin No	System	Description
70	LD	Output pin of APC amplifier
71	PD	Input pin of APC amplifier
72	AVEE (R)	Analog positive power supply input pin for RF part
73	N/C	No connection
74	PD2	Inverting input pin of RF I-V AMP2
75	PD1	Inverting input pin of RF I-V AMP1
76	F	Inverting input pin of F I-V AMP
77	E	Inverting input pin of E I-V AMP
78	P/N	Selecting P - sub/N - sub of Laser diode
79	DCC2	Defect bottom - hold output is inputted through capacitor
80	DCC1	Output pin of defect bottom - hold

## ABSOLUTE MAXIMUM RATINGS (Ta = 25°C)

Characteristic	Symbol	Value	Unit
Supply Voltage	V <sub>MAX</sub>	6	V
Power Dissipation	P <sub>D</sub>	900	mW
Operating Temperature	T <sub>OPR</sub>	-20 ~ +75	°C
Storage Temperature	T <sub>STG</sub>	-55 ~ +150	°C

## ELECTRICAL CHARACTERISTICS

(Ta = 25°C, AV<sub>CC</sub> = DV<sub>CC</sub> = +2.5V, AV<sub>EE</sub> = DV<sub>EE</sub> = -2.5V, GND = 0V, Unless Otherwise Specified)

Characteristic	No	Symbol	Test Conditions	Input pin	Output Pin	Min	Typ	Max	Unit
Supply Current	1	I <sub>CC</sub>				36	49	62	mA
RF AMP	Output Offset Voltage	V <sub>001</sub>			Pin66	- 80	0	80	mV
	Voltage Gain	G <sub>V1</sub>	V <sub>i</sub> = 1KHz, 40mV <sub>P-P</sub> Sinewave	Pin74	Pin66	25.1	28.1	31.1	dB
	Maximum Output Amplitude H	V <sub>OH(MAX)1</sub>	V <sub>i</sub> = 0.2V <sub>DC</sub> Output: + Peak Voltage	Pin74	Pin66	1.3			V
	Maximum Output Amplitude L	V <sub>OL(MAX)1</sub>	V <sub>i</sub> = -0.2V <sub>DC</sub> Output: - Peak Voltage	Pin74	Pin66			-0.3	V
FOCUS ERROR AMP	Output Offset Voltage	V <sub>002</sub>			Pin57	- 120		120	mV
	Voltage Gain PD1	G <sub>V2</sub>	V <sub>i</sub> = 1KHz, 40mV <sub>P-P</sub> Sinewave	Pin 75	Pin57	27.0	30.0	33.0	dB
	Voltage Gain PD2	G <sub>V3</sub>		Pin74	Pin57	27.0	30.0	33.0	dB
	Gain Difference Maximum	ΔG <sub>V1</sub>	GV2 - GV3			-3	0	3	dB
	Output Amplitude H	V <sub>OH(MAX)2</sub>	V <sub>i</sub> = 0.2V <sub>DC</sub> Output: + Peak Voltage	Pin74	Pin57	1.9			V
	Maximum Output Amplitude L	V <sub>OL(MAX)2</sub>	V <sub>i</sub> = -0.2V <sub>DC</sub> Output: - Peak Voltage	Pin74	Pin57			-1.9	V

## ELECTRICAL CHARACTERISTICS (CONTINUED)

Characteristic		No	Symbol	Test Conditions	Input pin	Output Pin	Min	Typ	Max	Unit
TRACK-ING ERROR AMP	Output Offset Voltage	12	$V_{OO3}$			Pin53	- 50	0	50	mV
	Voltage Gain F	13	$G_{V4}$	$V_I = 1\text{KHz}, 0.3\text{V}_{P-P}$ Sinewave	Pin76	Pin53	7.0	10.0	13.0	dB
	Voltage Gain E	14	$G_{V5}$	$G_{V4} - G_{V5}$	Pin77	Pin53	7.0	10.0	13.0	dB
	Gain difference	15	$\Delta G_{V2}$				-3	0	3	dB
	Maximum Output Amplitude H	16	$V_{OH(MAX)3}$	$V_I = 0.2V_{DC}$ Output: + Peak Voltage	Pin76	Pin53	1.9			V
	Maximum Output Amplitude L	17	$V_{OL(MAX)3}$	$V_I = -0.2V_{DC}$ Output: - Peak Voltage	Pin76	Pin53			-1.9	V
APC AMP	Output Voltage 1	18	$V_{01}$	$V_I = 190\text{mV} + V_{EE}$	Pin71	Pin70	1.4			V
	Output Voltage 2	19	$V_{02}$	$V_I = 90\text{mV} + V_{EE}$	Pin71	Pin70			-1.0	V
	Output Voltage 3	20	$V_{03}$	$V_I = 100\text{mV} + V_{EE}$	Pin71	Pin70	1.4			V
	Output Voltage 4	21	$V_{04}$	$V_I = 170\text{mV} + V_{EE}$	Pin71	Pin70			-1.0	V
	Output Voltage 5	22	$V_{05}$	$V_I = 0\text{mV} + V_{EE}$	Pin71	Pin70	1.4			V
	Output Voltage 6	23	$V_{06}$	$V_I = 0\text{mV} + V_{EE}$ $170 = 0.8\text{mA}$	Pin71	Pin70			-1.0	V
	Maximum Output Amplitude H	24	$V_{OH(MAX)4}$		Pin70	Pin70	0			V
	Maximum Output Amplitude L	25	$V_{OL(MAX)4}$	$V_I = 0\text{mV} + V_{EE}$ $170 = -0.8\text{mA}$	Pin70	Pin70			0	V



## ELECTRICAL CHARACTERISTICS (CONTINUED)

Characteristic		No	Symbol	Test Conditions	Input pin	Output Pin	Min	Typ	Max	Unit
FOK	Threshold Voltage	26	$V_{THI}$		Pin65	Pin59	-430	-380	-330	mV
	High Output Voltage	27	$V_{OH(FOK)1}$	$V_I = 45\text{KHz}$ , $-375\text{mV}_{DC}$ $1V_{P-P}$ Sinewave	Pin65	Pin59	2.2			V
	Low Output Voltage	28	$V_{OL(FOK)1}$		Pin65	Pin59			-1.8	V
MIRROR AMP	High Output Voltage	29	$V_{OH(MIR)1}$	$V_I = 10\text{KHz}$ , $-0.4\text{mV}_{DC}$ $0.8V_{P-P}$ Sinewave	Pin65	Pin5	1.8			V
	Low Output Voltage	30	$V_{OL(MIR)1}$		Pin65	Pin5			-2.2	V
	Bottom hold frequency	31	$F_{RES(B)}$	$V_I = 900\text{KHz}$ , $-0.4\text{mV}_{DC}$ $0.8V_{P-P}$ Sinewave	Pin65	Pin5		550	900	Hz
	Max operation frequency	32	$f_{1(MAX)1}$	$V_I = 30\text{KHz}$ , $-0.4\text{mV}_{DC}$ $0.8V_{P-P}$ Sinewave	Pin65	Pin5	30	75		KHz
DEFECT AMP	High Output Voltage	33	$V_{OH(DEF)1}$	$V_I = 1\text{KHz}$ , $15\text{mV}_{DC}$ $32\text{mV}_{P-P}$ Sinewave	Pin74	Pin4	1.8			V
	Low Output Voltage	34	$V_{OL(DEF)1}$		Pin74	Pin4			-2.2	V
	Minimum input Operating Frequency	35	$f_{1(MIN)}$	$V_I = 1\text{KHz}$ , $15\text{mV}_{DC}$ $32V_{P-P}$ Sinewave	Pin74	Pin4		670	1000	Hz
	Maximum input Operating Frequency	36	$f_{1(MAX)2}$	$V_I = 1\text{KHz}$ , $15\text{mV}_{DC}$ $32V_{P-P}$ Sinewave	Pin74	Pin4	2.0	4.7		KHz
EFM	Duty Cycle 1	37	$D_1$	$V_I = 750\text{KHz}$ , $0V_{DC}$ $0.7V_{P-P}$ Sinewave	Pin56	Pin37	-50	-	50	mV
	Duty Cycle 2	38	$D_2$	$V_I = 750\text{KHz}$ , $0.25V_{DC}$ Sinewave	Pin56	Pin37	0	50	100	mV
FOCUS SERVO	DC Voltage Gain	39	$V_{O(DC)1}$	$V_I = 0.1V_{DC}$	Pin56	Pin46	19.0	21.5	24.0	dB
	Output Voltage 1	40	$V_{O(FCS)1}$	$V_I = 0.5V_{DC}$	Pin56	Pin46	1.98			V
	Output Voltage 2	41	$V_{O(FCS)2}$	$V_I = -0.5V_{DC}$	Pin56	Pin46			-1.98	V
	Output Voltage 3	42	$V_{O(FCS)3}$	$V_I = 0.5V_{DC}$	Pin56	Pin46	1.18			V

## ELECTRICAL CHARACTERISTICS (CONTINUED)

Characteristic		No	Symbol	Test Conditions	Input pin	Output Pin	Min	Typ	Max	Unit
FOCUS SERVO	Output Voltage 4	43	$V_{O(FCS)4}$	$V_i = -0.5V_{DC}$	Pin56	Pin46			-1.18	V
	Search Output Voltage 1	44	$V_{O(SEARCH)1}$	Data = \$30 + \$02	Pin56	Pin46	-0.63	-0.50	-0.38	V
	Search Output Voltage 2	45	$V_{O(SEARCH)2}$	Data = \$30 + \$03	Pin56	Pin46	0.38	0.50	0.63	V
	AC Gain 1	46	$G_{V(AC)1}$	$V_i = 1.2KHz, 100mV_{P-P}$ Sinewave, SD = \$08	Pin56	Pin46	19.0	23.0	27.0	dB
	AC Gain 2	47	$G_{V(AC)2}$	$V_i = 1.2KHz, 100mV_{P-P}$ Sinewave, SD = \$0C	Pin56	Pin46	14.0	18.5	23.0	dB
TRACK -ING SERVO	DC Voltage Gain	48	$G_{V(DC)2}$	$V_i = -0.2V_{DC}$	Pin65	Pin48	13.5	15.5	17.5	dB
	Output Voltage 1	49	$V_{O(TCK)1}$	$V_i = -1.5V_{DC}$	Pin52	Pin48	1.98			V
	Output Voltage 2	50	$V_{O(TCK)2}$	$V_i = 1.5V_{DC}$	Pin52	Pin48			-1.98	V
	Output Voltage 3	51	$V_{O(TCK)3}$	$V_i = -1.5V_{DC}$	Pin74	Pin48	1.18			V
	Output Voltage 4	52	$V_{O(TCK)4}$	$V_i = 1.5V_{DC}$	Pin74	Pin48			-1.18	V
	Jump Output Voltage 1	53	$V_{O(JUMP)1}$			Pin48	-0.63	-0.50	-0.38	V
	Jump Output Voltage 2	54	$V_{O(JUMP)2}$			Pin48	0.38	0.50	0.63	V
	AC Gain 1	55	$G_{V(AC)3}$	$V_i = 1.2KHz, 100mV_{P-P}$ Sinewave	Pin52	Pin48	9.0	12.5	16.0	dB
AC Gain	56	$G_{V(AC)4}$	$V_i = 2.7KHz, 100mV$ Sinewave	Pin52	Pin48	17.5	21.5	25.5	dB	
SLED SERVO	DC Voltage Gain	57	$G_{V(DC)3}$	$V_i = 0.1V_{DC}$	Pin39	Pin40	21.0	23.0	25.0	dB
	Output Voltage 1	58	$V_{O(SLD)1}$	$V_i = 0.4V_{DC}$	Pin39	Pin40	1.98			V
	Output Voltage 2	59	$V_{O(SLD)2}$	$V_i = -0.4V_{DC}$	Pin39	Pin40			-1.98	V
	Output Voltage 3	60	$V_{O(SLD)3}$	$V_i = 0.4V_{DC}$	Pin39	Pin40	1.18			V

## ELECTRICAL CHARACTERISTICS (CONTINUED)

Characteristic		No	Symbol	Test Conditions	Input pin	Output Pin	Min	Typ	Max	Unit
SLED SERVO	Output Voltage 4	61	$V_{O(SLD)4}$	$V_I = -0.4V_{DC}$	Pin39	Pin40			-1.18	V
	Kick Output Voltage 1	62	$V_{O(KICK)1}$			Pin40	0.45	0.59	0.73	V
	Kick Output Voltage 2	63	$V_{O(KICK)2}$			Pin40	-0.73	-0.59	-0.45	V
SPINDLE SERVO	DC Voltage Gain	64	$G_V(DC)4$	$V_I = 0.2V_{DC}$	Pin12	Pin44	14.0	16.0	18.0	dB
	Output Voltage 1	65	$V_{O(SPD)1}$	$V_I = 1.0V_{DC}$	Pin12	Pin44	1.78			V
	Output Voltage 2	66	$V_{O(SPD)2}$	$V_I = -1.0V_{DC}$	Pin12	Pin44			-1.78	V
	Output Voltage 3	67	$V_{O(SPD)3}$	$V_I = 1.0V_{DC}$	Pin12	Pin44	1.13			V
	Output Voltage 4	68	$V_{O(SPD)4}$	$V_I = -1.0V_{DC}$	Pin12	Pin44			-1.13	V
PLL	Regulator Output Voltage	69	$V_{REG}$		Pin74		3.30	3.47	3.65	V
RF AMP	Maximum Output Amplitude H (L)	70	$V_{OH(MAX)5}$	$V_I = 0.2V_{DC}$ Output: + Peak Voltage	Pin74	Pin66	0.5			V
	Maximum Output Amplitude L (L)	71	$V_{OL(MAX)5}$	$V_I = -0.2V_{DC}$ Output: - Peak Voltage	Pin74	Pin66			-0.3	V
FOCUS ERROR AMP	Maximum Output Amplitude H (L)	72	$V_{OH(MAX)6}$	$V_I = 0.2V_{DC}$ Output: + Peak Voltage	Pin74	Pin57	1.1			V
	Maximum Output Amplitude L (L)	73	$V_{OL(MAX)6}$	$V_I = -0.2V_{DC}$ Output: - Peak Voltage	Pin74	Pin57			-1.1	V
TRACK- ING ERROR AMP	Maximum Output Amplitude H (L)	74	$V_{OH(MAX)7}$	$V_I = 0.2V_{DC}$ Output: + Peak Voltage	Pin74	Pin53	1.1			V
	Maximum Output Amplitude L (L)	75	$V_{OL(MAX)7}$	$V_I = -0.2V_{DC}$ Output: - Peak Voltage	Pin76	Pin53			-1.1	V
APC AMP	Output Voltage 7	76	$V_{O7}$	$V_I = 190mV + V_{EE}$	Pin71	Pin70	0.1			V

## ELECTRICAL CHARACTERISTICS (CONTINUED)

Characteristic		No	Symbol	Test Conditions	Input pin	Output Pin	Min	Typ	Max	Unit
APC AMP	Output Voltage 8	77	$V_{O8}$	$V_I = 90\text{mV} + V_{EE}$	Pin71	Pin70			-0.2	V
	Output Voltage 9	78	$V_{O9}$	$V_I = 100\text{mV} + V_{EE}$	Pin71	Pin70	0.6			V
	Output Voltage 10	79	$V_{10}$	$V_I = 170\text{mV} + V_{EE}$	Pin71	Pin70			0	V
	Output Voltage 11	80	$V_{11}$	$V_I = 0\text{V} + V_{EE}$	Pin71	Pin70	0.6			V
	Output Voltage 12	81	$V_{12}$	$V_I = 0\text{V} + V_{EE}$	Pin71	Pin70			-0.2	V
FOK	Threshold Voltage 2	82	$V_{TH2}$		Pin65	Pin59	-430	-380	-330	mV
	Low Output Voltage	83	$V_{OH(FOK)2}$	$V_I = 45\text{KHz}$ , - 375mV <sub>DC</sub> 1V <sub>P-P</sub> Sinewave	Pin65	Pin59	1.2			V
	High Output Voltage	84	$V_{OL(FOK)2}$		Pin65	Pin59			-1.0	V
MIRROR AMP	Low Output Voltage	85	$V_{OH(MIR)2}$	$V_I = 10\text{KHz}$ , - 0.4V <sub>DC</sub> 0.8V <sub>P-P</sub> Sinewave	Pin65	Pin5	1.0			V
	High Output Voltage	86	$V_{OL(MIR)2}$		Pin65	Pin5			-1.2	V
DEFECT AMP	High Output Voltage	87	$V_{OH(DEF)2}$	$V_I = 1\text{KHz}$ , 15mV <sub>DC</sub> 32V <sub>P-P</sub> Sinewave	Pin74	Pin4	1.0			V
	Low Output Voltage	88	$V_{OL(DEF)2}$		Pin74	Pin4			-1.2	V
EFM	Duty Cycle 3	89	$D_3$	$V_I = 750\text{KHz}$ , 0V <sub>DC</sub> 0.7V <sub>P-P</sub> Sinewave	Pin65	Pin37	-50	0	50	mV
	Duty Cycle 4	90	$D_4$	$V_I = 750\text{KHz}$ , 0.25V <sub>DC</sub> Sinewave	Pin65	Pin37	0	50	100	mV
FOCUS SERVO	Output Voltage 5	91	$V_{O(fcs)5}$	$V_I = 0.5\text{V}_{DC}$	Pin56	Pin46	1.18			V
	Output Voltage 6	92	$V_{O(fcs)6}$	$V_I = -0.5\text{V}_{DC}$	Pin56	Pin46			-1.18	V
	Search Output Voltage 3	93	$V_{O(SEARC)3}$			Pin46	-0.63	-0.50	-0.38	V
	Search Output Voltage 4	94	$V_{O(SEARC)4}$			Pin46	0.38	0.50	0.63	V

## ELECTRICAL CHARACTERISTICS (CONTINUED)

Characteristic		No	Symbol	Test Conditions	Input pin	Output Pin	Min	Typ	Max	Unit
TRACK-ING SERVO	Output Voltage 5	95	$V_{O(Trk)5}$	$V_I = -1.5V_{DC}$	Pin52	Pin48	1.18			V
	Output Voltage 6	96	$V_{O(Trk)6}$		Pin52	Pin48			-1.18	V
	Jump Output Voltage 3	97	$V_{O(JUMP)3}$			Pin48	-0.63	-0.50	-0.38	V
	Jump Output Voltage 4	98	$V_{O(JUMP)4}$			Pin48	0.38	0.50	0.63	V
SLED SERVO	Output Voltage 5	99	$V_{O(SLD)}$	$V_I = 0.4V_{DC}$	Pin39	Pin40	1.18			V
	Output Voltage 6	100	$V_{O(SLD)}$	$V_I = -0.4V_{DC}$	Pin39	Pin40			-1.18	V
	Kick Output Voltage 3	101	$V_{O(KICK)3}$			Pin40	0.40	0.54	0.68	V
	Kick Output Voltage 4	102	$V_{O(KICK)4}$			Pin40	-0.68	-0.64	-0.40	V
SPINDLE SERVO	Output Voltage 5	103	$V_{OH(SPD)5}$	$V_I = 1.0V_{DC}$	Pin12	Pin44	0.98			V
	Output Voltage 6	104	$V_{OL(SPD)6}$	$V_I = -1.0V_{DC}$	Pin12	Pin44			-0.98	V



**DESCRIPTION OF FUNCTION**

1. RF AMP BLOCK

1) Description

The KA9220C is designed for 3-spot type optical pick-up assembly. The photo detector is composed of 6 light sensor (A through F). The photo detector A, B, C and D detect audio modulation signal on the disc and generate focus error signal. The E and F photo detectors generate tracking error signal.

2) RF AMPLIFIER

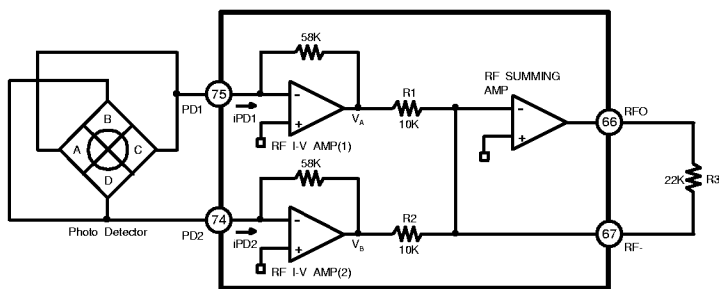

RF I - V AMP (1) and RF I - V AMP (2) are converted current of PD1 (A + C) and PD2 (B + D) through the 58 Kohm Internal resistor into Voltage.

Furthermore, they are added to RF Summing amplifier.

This signal (A + B + C + D) is outputted from RFO (Pin66).

The output Voltage is as follow.

$$V_{RFO} = - R3 \times (iPD1 + iPD2)$$

$$= - R3 \times \left( \frac{V_A}{R_1} + \frac{V_B}{R_2} \right)$$

$$= - 22K \times \left( \frac{V_A}{10K} + \frac{V_B}{10K} \right)$$

$$= - 2.2 \times (V_A + V_B)$$

3) TRACKING ERROR AMPLIFIER

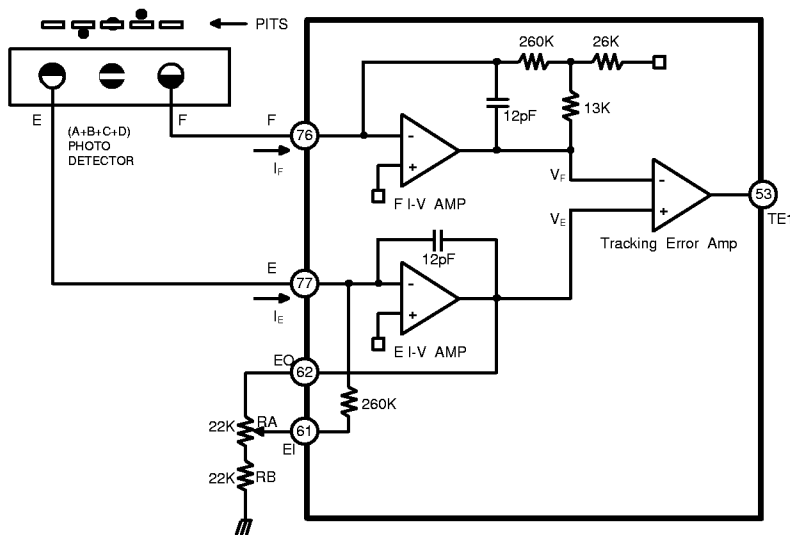

The output of photo detector F is directed to the (-) Input of F I - VAMP and out of photo detector E is directed to the (-) input of E I - V AMP.

These input signals are current.

E I-V AMP and F I-V AMP are converted into voltage from the current signal. When correct tracking, two input ( $V_F$ ,  $V_E$ ) signals are equal. The occurrence of tracking error is due to difference between F I-V AMP output and E I-V AMP output.

$$V_F = I_F \times \left[ \left( \frac{260K \times 13K}{26K} \right) + 273K \right] = I_F \times 403K$$

$$V_E = I_E \times \left[ \left( \frac{R_A}{R_B + 22K} \right) + 260K + R_A + 260K \right]$$

accordingly,  $V_{TE1} = (I_E - I_F) \times 1290K$



4) FOCUS ERROR AMPLIFIER

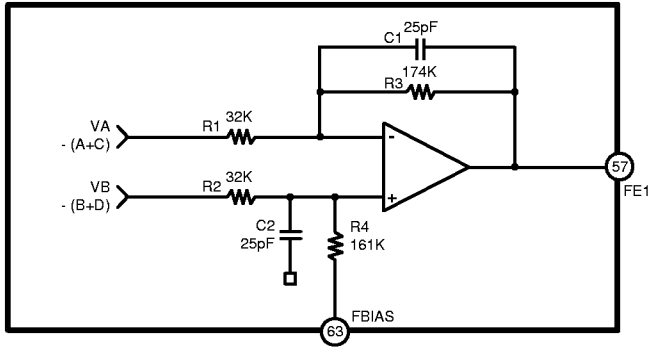

The focus error amp is the difference between RF I-V AMP (1) output VA and RF I-V AMP (2) output VB. This two (VA, VB) signals are each applied to the (-) and (+) input of focus error amp. As the result of differential voltage, Focus error signal is appeared at FE1 Pin (Pin57). This FE1 Output Voltage (low frequency) becomes (A + C) - (B + D), as follow  $V_{FE1} = R_1/R_3 (V_B - V_A)$ . The focus error voltage is directed to the focus servo Block, to maintain optimum focusing at all times.

5) FOCUS OK GENERATION CIRCUIT

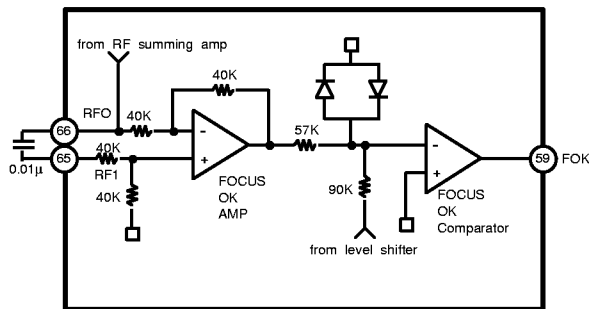



7) DEFECT CIRCUIT

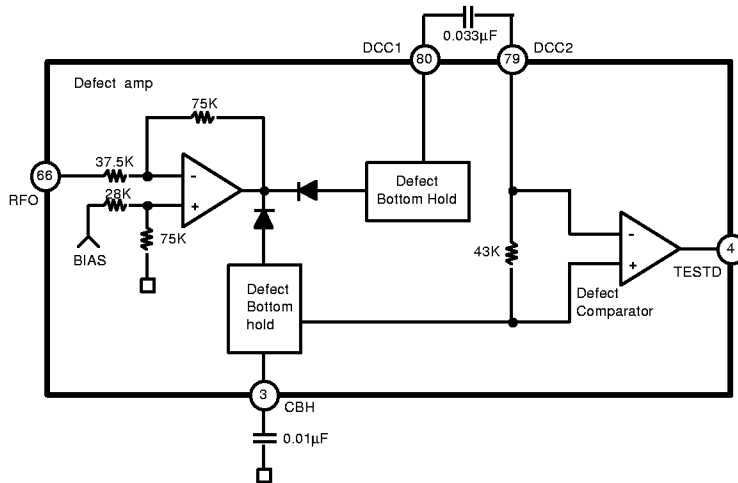

The bottom hold has had two time constant of long and short, after than the RFI signal inverted. The short time constant of bottom hold is generated shorter than 0.1m sec of disc mirror defect, and long time constant is generated by previous mirror level. Mirror defect detection signals are generated by differentiation on Capacitor Coupling, and then transfer level.

8) EFM COMPARATOR

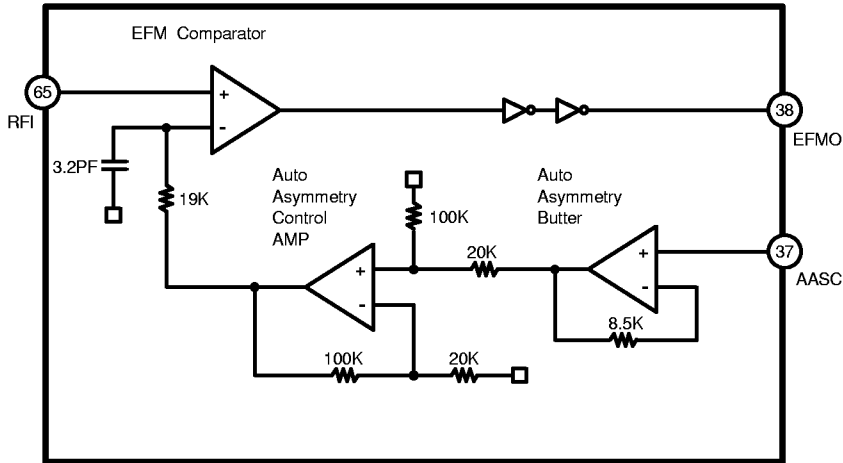

The EFM Comparator converts a RF Signal into a binary signal. A processing of disc production is occurred disproportion because of modification of disc.  
 That is not reduced by only AC coupling.  
 The reference voltage of EFM comparator is controlled utilizing the fact that the generation-probability 1, 0 is 50% (duty) in the binary EFM signal.

9) APC (AUTOMATIC POWER CONTROL) CIRCUIT

A. + 5V Single Power Supply P-sub Laser

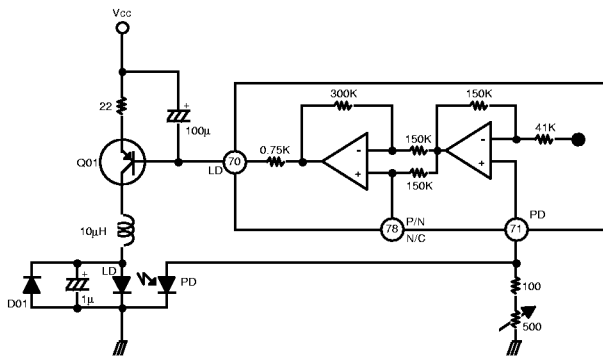

B. + 5V Single Power Supply N-sub Laser

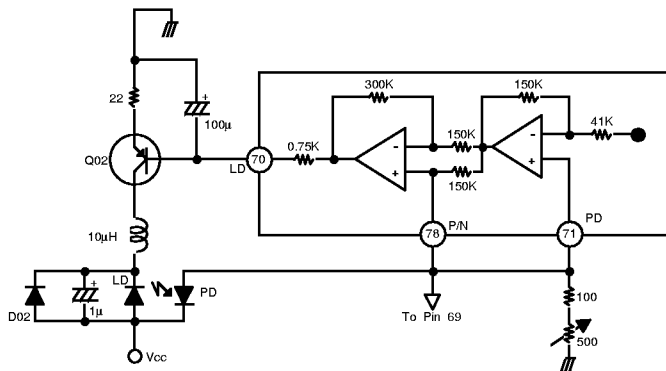

As the Laser diode has had large negative temperature characteristic when it does something for regularly supply current on laser diode. Therefore, the output on processing monitor photo diode must be controlled current for getting regularly output power. This APC circuit is composed by single powersupply operation. This circuit can use p-sub and N-sub of laser diode according to application circuit.

2. SERVO BLOCK

1) FOCUS SERVO BLOCK

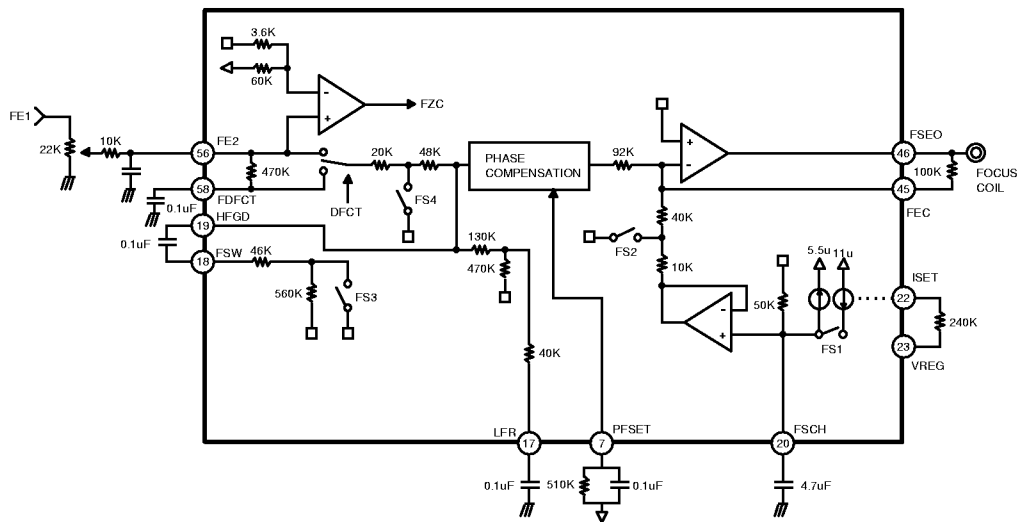

When the defect signal is detected, the focus servo Loop is isolated. At this time, the focus servo error output is outputted through low pass filter formed by connecting a capacitor (0.1 $\mu$ F) between the built-in 470K $\Omega$  resistor and FDFCT Pin (Pin58). Accordingly, the focus error output is held as just before error value during the defect. The peak frequency of the focus phase compensation is at about 1.2KHz when the resistor connected to PFSET (Pin7) is 510K $\Omega$ . It is inversely proportional to the resistor connected to the Pin 7. While the focus search is operating, the FS4 switch is ON and then Focus error signal is isolated, accordingly it is outputted by FSEO Pin (Pin48). When the FS2 switch is ON, the focus servo Loop is on and then focus error is outputted through the focus servo Loop.



3) SPINDLE SERVO AND LOW PASS FILTER

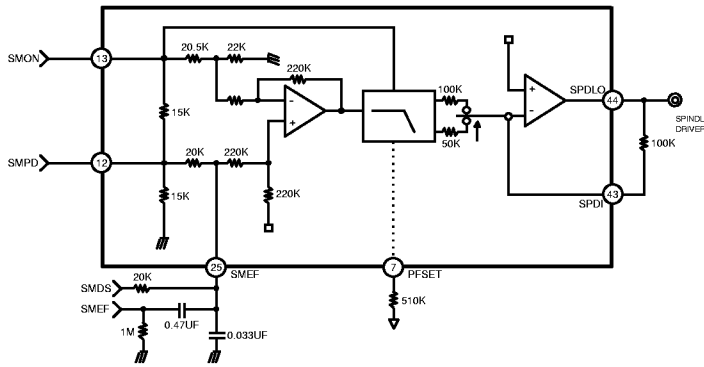

The 0.033nF and the 20K $\Omega$  connected to Pin25 (SMEF) form the 200Hz low Pass filter.  
 And the carrier component of spindle servo error signals is eliminated.  
 In the CLV - S mode, SMEF becomes L and Pin25 LPF fc lowers, strengthening the filter further.



3. COMMANDS

1) CPU Serial interface timing chart

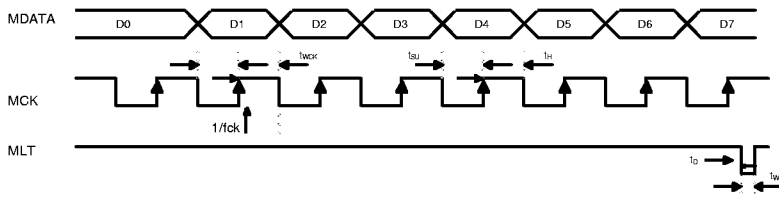

Item	Symbol	Min.	Typ.	Max.	Unit
Clock frequency	$f_{ck}$			1	MHz
Clock pulse width	$t_{wck}$	500			ns
Hold time	$t_{su}$	500			ns
Setup time	$t_h$	500			ns
Delay time	$t_d$	500			ns
Latch pulse width	$t_{wl}$	1000			ns

**2) HEXA COMMANDS**

1. \$0X

- This command controls focus servo Loop.

D7	D6	D5	D4	D3	D2	D1	D1
0	0	0	0	FS4	FS3	FS2	FS1

- \$00

If FS1 = 0, Pin20 is charged to  $(11\mu\text{A} - 5.5\mu\text{A}) \times 50\text{K}\Omega = 0.275\text{V}$ .

- \$02

The Pin46 Voltage level is as follow,

$(11\mu\text{A} - 5.5\mu\text{A}) \times 50\text{K}\Omega \times \text{feed back resistor } 50\text{K}\Omega$

The focus search voltage is produced by \$02 and \$03

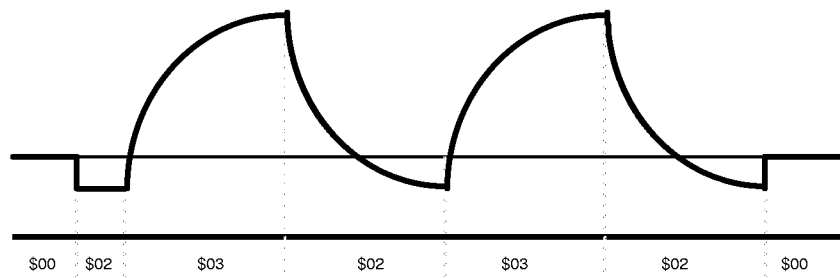

- FS4 SWITCH

\$00- Focus servo off

\$08- Focus servo on

# KA9220C

# RF AMP + SSP

### 2. \$1X.

This command controls tracking servo Loop Gain and Break circuit

D7	D6	D5	D4	D3	D2	D1	D1
0	0	0	1	Anti Shock ON/OFF	Break Circuit ON/OFF	TG2	TG1

### 3. \$2X.

D7	D6	D5	D4	D3	D2	D1	D1
0	0	1	0	Tracking control 0 0 OFF 0 1 SERVO ON 1 0 F - Jump 1 1 R - Jump TM1, TM3, TM4		SLED Control 0 0 OFF 0 1 SERVO ON 1 0 F - Kick 1 1 R - Kick TM2, TM5, TM6	

### 4.S3X.

- D0, D1 : SLED Normal Kick
- D2, D3 : Focus Search Peak

D7	D6	D5	D4	Focus Search		SLED Kick Peak		Relative value
				D3 (PS3)	D2 (PS2)	D1 (PS1)	D0 (PS0)	
0	0	0	1	0	0	0	0	± 1
				0	1	0	1	± 2
				1	0	1	0	± 3
				1	1	1	1	± 4

### 5. \$4X to \$7X

\$4X to \$7X are for the auto sequencer commands.

3) Other

1. DIRC

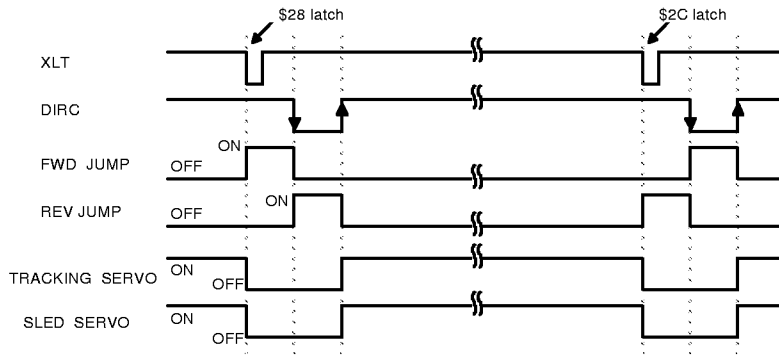

2. LOCK (Sled runaway prevention circuit)

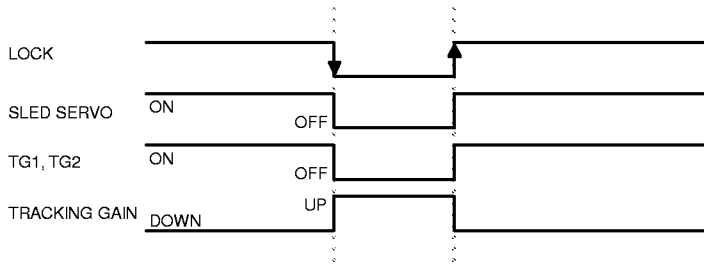

3. DEFECT (Disc defect countermeasure circuit)

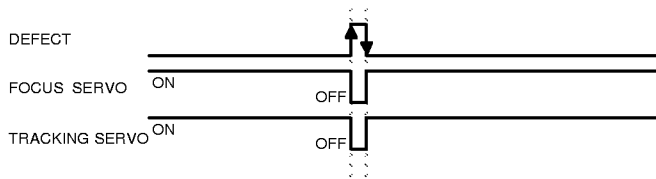

# KA9220C

# RF AMP + SSP

## 4) System Control

ITEM	HEXA	ADDRESS				DATA				ISTAT	
		D7	D6	D5	D4	D3	D2	D1	D0	OUT	
FOCUS CONTROL	\$0X	0	0	0	0	FS4 FOCUS ON	FS3 GAIN DOWN	FS2 SEARCH ON	FS1 SEARCH UP	FZC	
TRACKING CONTROL	\$1X	0	0	0	1	ANTI SHOCK	BREAK ON	TG2 GAIN SET	TG1 GAIN SET	A . S	
TRACKING MODE	\$2X	0	0	1	0	TRACKING MODE		SLED MODE		TZC	
SELECT	\$3X	0	0	1	1	PS4 FOCUS SEARCH + 2	PS3 FOCUS SEARCH + 1	PS2 SLED KICK + 2	PS1 SLED KICK + 1	STOP	
AUTO SEQUENCE	\$4X	0	1	0	0	AS3	AS2	AS1	AS0		
RAM SET	BLIND (A< E)/ OVER FLOW	\$5X	0	1	0	1	0.18ms	0.09ms	0.045ms	0.022ms	Hi - Z
	BREAK (B)		0	1	0	1	0.36ms	0.18ms	0.09ms	0.045ms	
	KICK (D)	\$6X	0	1	1	0	11.6ms	5.8ms	2.90ms	1.455ms	
	TRACK JUMP (N)	\$7X	0	1	1	1	64	32	16	8	
	TRACK JUMP (M)						128	64	32	16	
NORMAL SPEED	\$F0										
DOUBLE SPEED	\$F3										

5) Serial data truth table

1. Focus control

SERIAL DATA	HEXA	SWITH			
FOCUS CONTROL		FS4	FS3	FS2	FS1
0 0 0 0 0 0 0 0	\$00	0	0	0	0
0 0 0 0 0 0 0 1	\$01	0	0	0	1
0 0 0 0 0 0 1 0	\$02	0	0	1	0
0 0 0 0 0 0 1 1	\$03	0	0	1	1
0 0 0 0 0 1 0 0	\$04	0	1	0	0
0 0 0 0 0 1 0 1	\$05	0	1	0	1
0 0 0 0 0 1 1 0	\$06	0	1	1	0
0 0 0 0 0 1 1 1	\$07	0	1	1	1
0 0 0 0 1 0 0 0	\$08	1	0	0	0
0 0 0 0 1 0 0 1	\$09	1	0	0	1
0 0 0 0 1 0 1 0	\$0A	1	0	1	0
0 0 0 0 1 0 1 1	\$0B	1	0	1	1
0 0 0 0 1 1 0 0	\$0C	1	1	0	0
0 0 0 0 1 1 0 1	\$0D	1	1	0	1
0 0 0 0 1 1 1 0	\$0E	1	1	1	0
0 0 0 0 1 1 1 1	\$0F	1	1	1	1

2. Tracking Gain control

SERIAL DATA	HEXA	SWITH			
		AS = 0		AS = 1	
		TG2	TG1	TG2	TG1
0 0 0 1 0 0 0 0	\$10	0	0	0	0
0 0 0 1 0 0 0 1	\$11	0	1	0	1
0 0 0 1 0 0 1 0	\$12	1	0	1	0
0 0 0 1 0 0 1 1	\$13	1	1	1	1
0 0 0 1 0 1 0 0	\$14	0	0	0	0
0 0 0 1 0 1 0 1	\$15	0	1	0	1
0 0 0 1 0 1 1 0	\$16	1	0	1	0
0 0 0 1 0 1 1 1	\$17	1	1	1	1
0 0 0 1 1 0 0 0	\$18	0	0	1	1
0 0 0 1 1 0 0 1	\$19	0	1	1	0
0 0 0 1 1 0 1 0	\$1A	1	0	0	1
0 0 0 1 1 0 1 1	\$1B	1	1	0	0
0 0 0 1 1 1 0 0	\$1C	0	0	1	1
0 0 0 1 1 1 0 1	\$1D	0	1	1	0
0 0 0 1 1 1 1 0	\$1E	1	0	0	1
0 0 0 1 1 1 1 1	\$1F	1	1	0	0

3. Tracking mode control

SERIAL DATA	HEXA	Function		
		DIRC = 1 TM = 6 5 4 3 2 1	DIRC = 0 TM = 6 5 4 3 2 1	DIRC = 1 TM 6 5 4 3 2 1
0 0 1 0 0 0 0 0	\$20	0 0 0 0 0 0	0 0 1 0 0 0	0 0 0 0 1 1
0 0 1 0 0 0 0 1	\$21	0 0 0 0 1 0	0 0 1 0 1 0	0 0 0 0 1 1
0 0 1 0 0 0 1 0	\$22	1 0 0 0 0 0	1 0 1 0 0 0	0 1 0 0 0 1
0 0 1 0 0 0 1 1	\$23	0 1 0 0 0 0	0 1 1 0 0 0	0 1 0 0 0 1
0 0 1 0 0 1 0 0	\$24	0 0 0 0 0 1	0 0 0 1 0 0	0 0 0 0 1 1
0 0 1 0 0 1 0 1	\$25	0 0 0 0 1 1	0 0 0 1 1 0	0 0 0 0 1 1
0 0 1 0 0 1 1 0	\$26	1 0 0 0 0 1	1 0 0 1 0 0	0 1 0 0 0 1
0 0 1 0 0 1 1 1	\$27	0 1 0 0 0 1	0 1 0 1 0 0	0 1 0 0 0 1
0 0 1 0 1 0 0 0	\$28	0 0 0 1 0 0	0 0 1 0 0 0	0 0 0 0 1 1
0 0 1 0 1 0 0 1	\$29	0 0 0 1 1 0	0 0 1 0 1 0	0 0 0 0 1 1
0 0 1 0 1 0 1 0	\$2A	1 0 0 1 0 0	1 0 1 0 0 0	0 1 0 0 0 1
0 0 1 0 1 0 1 1	\$2B	0 1 0 1 0 0	0 1 1 0 0 0	0 1 0 0 0 1
0 0 1 0 1 1 0 0	\$2C	0 0 1 0 0 0	0 0 0 1 0 0	0 0 0 0 1 1
0 0 1 0 1 1 0 1	\$2D	0 0 1 0 1 0	0 0 0 1 1 0	0 0 0 0 1 1
0 0 1 0 1 1 1 0	\$2E	0 0 1 0 0 0	1 0 0 1 0 0	0 1 0 0 0 1
0 0 1 0 1 1 1 1	\$2F	0 1 1 0 0 0	0 1 0 1 0 0	0 1 0 0 0 1



## 4. Auto Sequence

	AS3	AS2	AS1	AS0
CANCEL	0	0	0	0
FOCUS ON	0	1	1	1
1 TRACK JUMP	1	0	0	X
10 TRACK JUMP	1	0	1	X
2N TRACK JUMP	1	1	0	X
M TRACK MOVE	1	1	1	X

X = 0 forward X = 1 reverse

Dimensions in Millimeters

80-QFP-1212

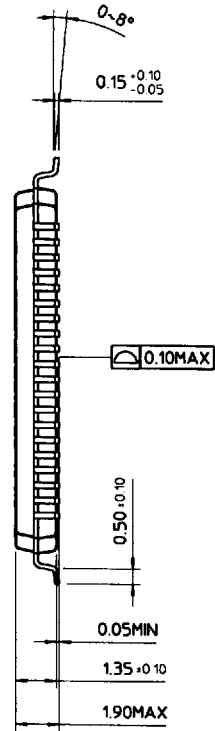
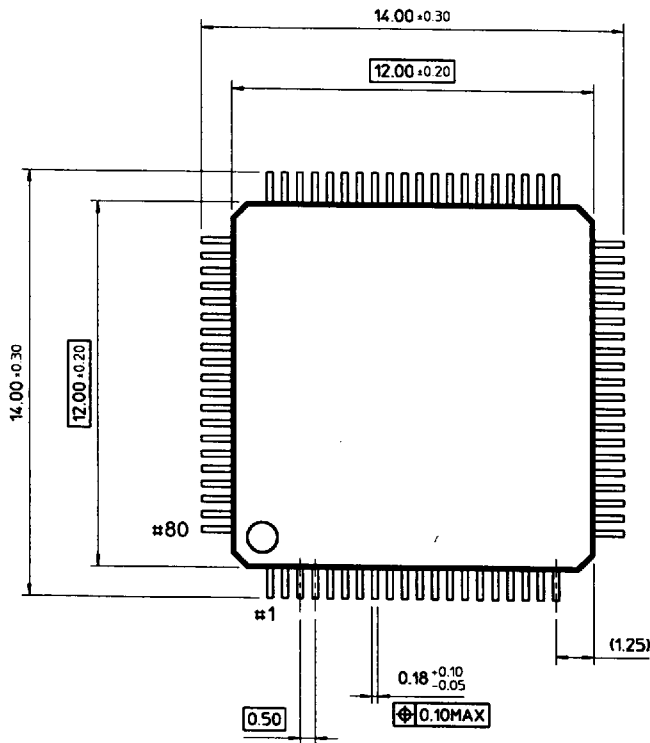

80-QFP-1420C

