

7294621 POWEREX INC

98

DE

7294621

0002265

D

T-33-35

POWEREX

KD7212A2

Powerex, Inc., Hillis Street, Youngwood, Pennsylvania 15697 (412) 925-7272

Dual Darlington Transistor Module
25 Amperes/1200 Volts

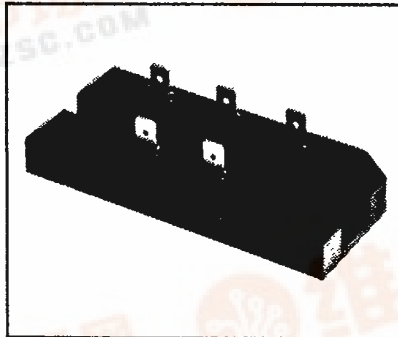
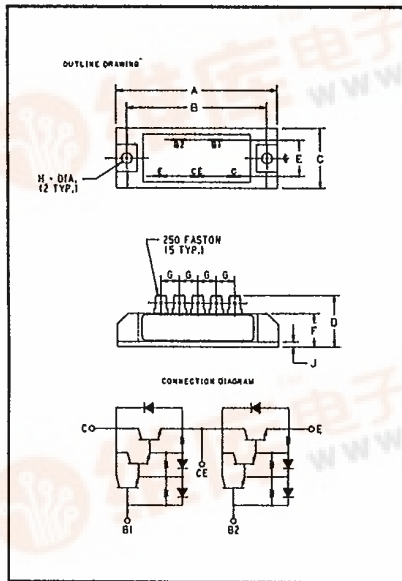

KD7212A2
Dual Darlington Transistor Module
25 Amperes/1200 Volts

Description

Powerex Dual Darlington Transistor Modules are designed for use in switching applications. The modules are isolated consisting of two Darlington Transistors with each transistor having a reverse parallel connected high-speed diode.

Features:

- Isolated Mounting
- Planar Chips
- Discrete Fast Recovery Feed-Back Diode
- High Gain (h_{FE})
- Fast On Connections
- Base Emitter Speed Up Diodes

Applications:

- Inverters
- DC Motor Control
- Switching Power Supplies
- AC Motor Control

Ordering Information

Example: Select the complete eight digit module part number you desire from the table - i.e. KD7212A2 is a 1200 Volt, 25 Ampere Dual Darlington Module.

1200 Volt KD7212A2
Outline Drawing

Dimension	Inches	Millimeters
A	3.622	92
B	3.150 ± .012	80 ± 0.3
C	1.378	35
D	1.181 Max.	30 Max.
E	.827	21
F	.768	19.5
G	.413	10.5
H	.216 Dia.	5.5 Dia.
J	.177	4.5

Type	V _{CE(SUS)} Volts (×100)	Current Rating Amperes (25)
KD72	12	A2



Powerex, Inc., Hillis Street, Youngwood, Pennsylvania 15697 (412) 925-7272

KD7212A2

Dual Darlington Transistor Module

25 Amperes/1200 Volts

Maximum Ratings $T_J = 25^\circ\text{C}$ unless otherwise specified

	Symbol	KD7212A2	Units
Junction Temperature	T_J	-40 to 150	$^\circ\text{C}$
Storage Temperature	T_{STG}	-40 to 125	$^\circ\text{C}$
Collector-Emitter Sustaining Voltage	$V_{CE0(SUS)}$	950	Volts
Collector-Emitter Sustaining Voltage $V_{BE} = -2\text{V}$	$V_{CEV(SUS)}$	1200	Volts
Collector-Base Voltage	V_{CBO}	1200	Volts
Emitter-Base Voltage	V_{EBO}	7	Volts
Collector-Emitter Voltage $V_{BE} = -2\text{V}$	V_{CEV}	1200	Volts
Continuous Collector Current	I_C	25	Amperes
Diode Forward Current	I_{FM}	25	Amperes
Continuous Base Current	I_B	1.5	Amperes
Diode Surge Current	I_{FSM}	250	Amperes
Power Dissipation, Each Transistor	P_T	208	Watts
Max. Mounting Torque M5 Mounting Screws	—	17	in.-lb.
Module Weight	—	155	Grams
V isolation	V_{RMS}	2500	Volts

Electrical and Mechanical Characteristics $T_J = 25^\circ\text{C}$ unless otherwise specified

Characteristics	Symbol	Test Conditions	KD7212A2			Units
			Min.	Typ.	Max.	
Collector Cutoff Current	I_{CEV}	$V_{CE} = 1200\text{V}, V_{BE} = -2\text{V}$	—	—	1	mA
Emitter Cutoff Current	I_{EBO}	$V_{EB} = 7\text{V}$	—	—	200	mA
DC Current Gain	h_{FE}	$I_C = 25\text{A}, V_{CE} = 5\text{V}$	75	—	—	—
Diode Forward Voltage	V_{FM}	$I_{FM} = 25\text{A}$	—	—	1.8	V
Collector-Emitter Saturation Voltage	$V_{CE(SAT)}$	$I_C = 25\text{A}, I_B = 0.5\text{A}$	—	—	3	V
Base-Emitter Saturation Voltage	$V_{BE(SAT)}$	$I_C = 25\text{A}, I_B = 0.5\text{A}$	—	—	3.5	V
Resistive Turn On	t_{on}	$V_{CC} = 600\text{V}$	—	—	2.5	μs
Load Storage Time	t_s	$I_C = 25\text{A}$	—	—	15	μs
Switch Times Fall Time	t_f	$I_{B1} = -I_{B2} = 0.5\text{A}$	—	—	3.0	μs
Thermal Resistance, Case to Sink Lubricated	$R_{\theta CS}$	Per Half Module	—	—	0.15	$^\circ\text{C}/\text{W}$
Thermal Resistance, Junction to Case	$R_{\theta JC}$	Transistor Part	—	—	0.6	$^\circ\text{C}/\text{W}$
Thermal Resistance, Junction to Case	$R_{\theta JC}$	Diode Part	—	—	1.5	$^\circ\text{C}/\text{W}$