



# MIL-STD-461-C INPUT EMI FILTER for 4W up to 50W DC/DC Converters KG 9501

捷多邦 专业PCB打样工厂 24小时加急出货

Accessories

- To comply with MIL-STD-461-C power leads :
  - CE 03 : Emission requirement over 15 kHz
  - CS 01 : Susceptibility requirement over 30Hz to 50KHz
  - CS 02 : Susceptibility requirement over 50KHz to 400MHz
  - CS 06 : Susceptibility
- Current range up to 2A
- Reverse polarity protection
- SMD Components
- Small surface : 20 mm x 25 mm (0.8" x 1")
- Temperature range : -55°C/+105°C



## 1-Subject

The EMI front filter kit KG9501 enables Gaia Converter DC/DC modules or preregulators front-end modules below 50W power to be fully compliant with the MIL-STD-461-C Part 2 & 3 standard as follow :

- CE03, class A1, narrowband
- CE03, class A1, broadband, curve# 1 & 2
- CS01, class A1, consult factory for criteria
- CS02, class A1
- CS06, class A1, spike # 2

This EMI front filter kit is compatible with all GAIA Converter DC/DC modules with J family of input range (16-40 Vdc) or H family of input range (9-36 Vdc), with all pre-regulator PGDS-50 series and can drive up to 2A input current.

This EMI front filter KG9501 is a kit of 15 components as follow.

## 2- Components

- D1 ..... : Diode TO-220 format, BYW29-200 SGS-Thomson or Philips
- L1 ..... : Common mode choke Fair-rite type 2744041447 or equivalent Ferroxcube CMS2-5.6/3/4.8-4S2 (replacement of obsolete Philips type 12NC433003036881)
- L2 ..... : Ferrite bead Fair-rite type 2743021447 or equivalent Ferroxcube type BDS 3/3/8.9-3S1 (replacement of obsolete Philips type 12NC43300303645)
- L3 ..... : Ferrite bead Fair-rite type 2743021447 or for better performances differential mode inductance Coilcraft type D03316P-472 (both components are provided in the GAIA Converter kit.)
- C1, C2, C3 & C4\* : SMD 10µF tantalum capacitor, 7343D 10µF 20% 293D serial D package CTC3 type
- C5 & C6 ..... : SMD 1206 ceramic capacitor, 100nF/50 V 20% X7R type Vishay reference VJ1206Y104MXAT or TDK reference C3216x7R1H104KT
- R1, R2, R3 & R4 : SMD 0805 resistor, 1M 5% 200 PPM 150V 0.125W

\* Note : The choice of capacitor rating values depends on level of transients required (i.e 60V, 80V or 100V)



### 3- Schematic

The EMI front filter kit KG9501 can be used either :

- directly in front of any GAIA Converter DC/DC modules or assembly of DC/DC modules up to 50W power
- in front of GAIA Converter pre-regulator PGDS-50 series.

Both schematics are resumed hereafter.

#### 3-1 Connection to GAIA Converter DC/DC Converter

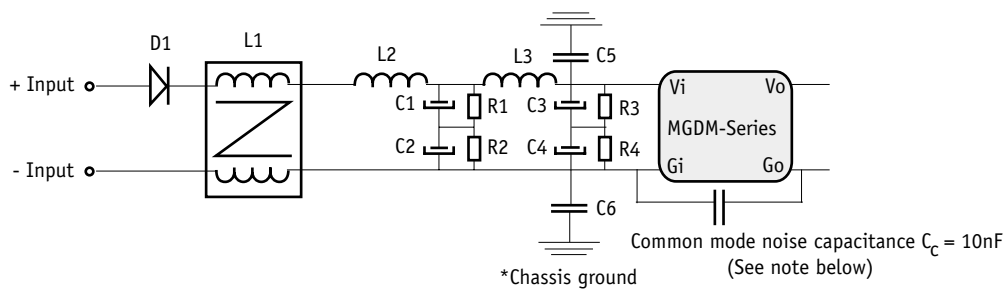

Notes : it is suggested to use a common mode capacitor  $C_c$  (10 nF/1.500V) to increase EMI performance. This capacitor should be layed-out as close as possible from the DC/DC converter.

\* For connection to chassis ground, if a higher isolation is required, it is suggested to use 10nF with voltage rating compliant with application requirements as capacitors C5 and C6.

#### 3-2 Connection to GAIA Converter Pre-regulator PGDS-50 & DC/DC Converters

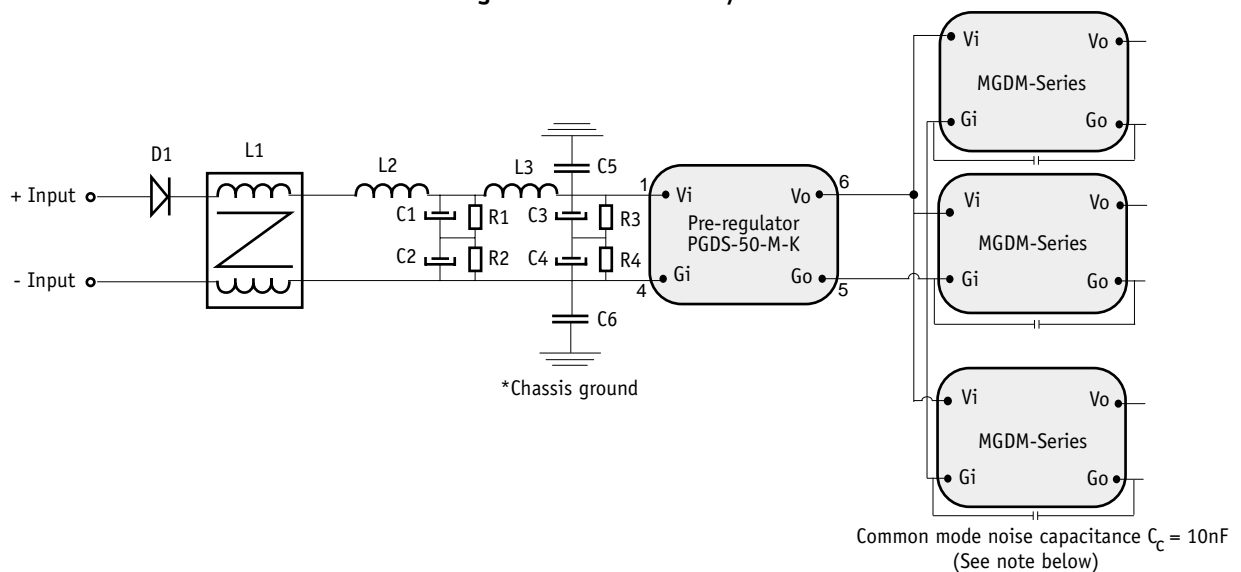

Notes : it is suggested to use a common mode capacitor  $C_c$  (10 nF/1.500V) for each DC/DC converter to increase EMI performance. This capacitor should be layed-out as close as possible from the DC/DC converter.

\* For connection to chassis ground, if a higher isolation is required, it is suggested to use 10nF with voltage rating compliant with application requirements as capacitors C5 and C6.

### 4- Component Dimensions

#### 4-1 Differential Mode Inductance Implementation & Dimensions (L3)

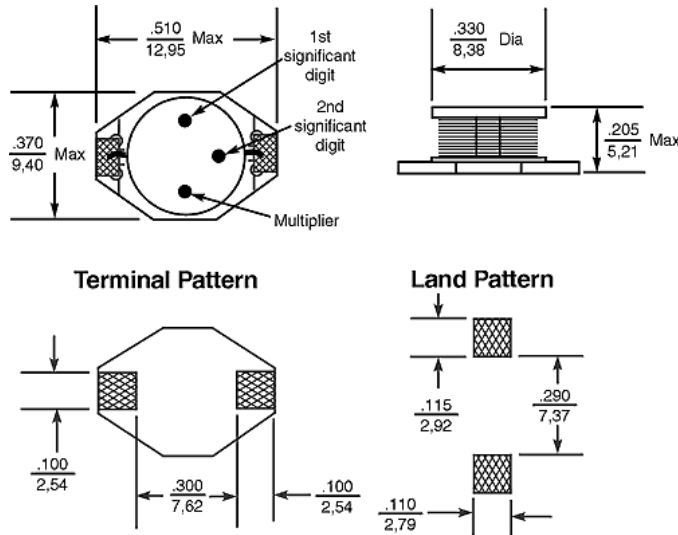

#### 4-2 Ferrite Bead Implementation & Dimensions (L2)

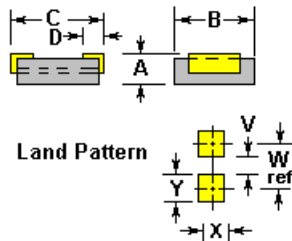

Conductor in Figure herabove is 1.27 mm (.050) wide x 0.2 mm (.008) thick flat TCW

Impedance (Ω) @ 10 MHz	Impedance (Ω) @ 25 MHz	Impedance (Ω) @ 100MHz	Rdc (mΩ)	Wt (g)	A (mm/in)	B (mm/in)	C (mm/in)	D (mm/in)	V (mm/in)	W (mm/in)	X (mm/in)	Y (mm/in)	TapeWidth	Parts per Reel
48 min	45 min	95±20%	0.9 max	.30	<b>2.85±0.2</b> .112	<b>3.05±0.1</b> .120	<b>9.6-0.95</b> .359	<b>1.5±0.5</b> .059	4.5 .177	7.5 .295	1.8 .071	3.0 .118	<b>16</b> .629	2800

Bold numbers are in mm, light numbers are in inch

#### 4-3 Common Mode Choke Implementation & Dimensions (L1)

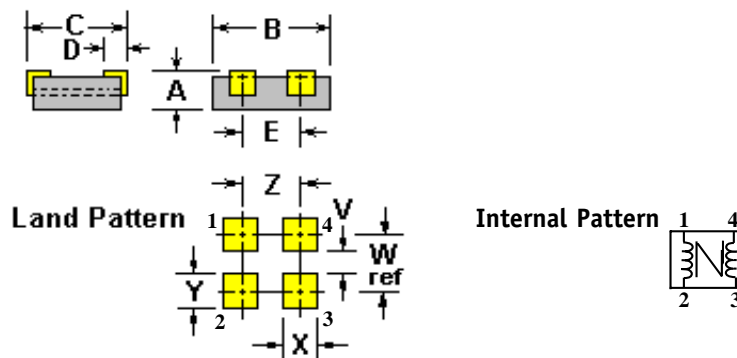

Impedance (γ) @ 25 MHz	Impedance (γ) @ 100 MHz	Rdc (mγ)	Wt (g)	A (mm/in)	B (mm/in)	C (mm/in)	D (mm/in)	E (mm/in)	V (mm/in)	W (mm/in)	X (mm/in)	Y (mm/in)	Z (mm/in)	TapeWidth	Parts per Reel
16min	33±20%	0.8 max	.30	<b>2.85±0.2</b> .112	<b>5.6±0.2</b> .220	<b>5.0-0.6</b> .185	<b>1.35±0.25</b> .053	<b>2.54±0.1</b> .1	1.0 .040	4.0 .157	1.8 .071	3.0 .118	2.54 .100	<b>12</b> .472	2400

Bold numbers are in mm, light numbers are in inch

## 5- Lay-out Recommendation

### 5-1 Grounding Design

GAIA Converter recommend to use four layer boards. The two outer layers will be used for power and ground planes, and the two inner layers for low levels signals. Where necessary, extra planes to beef-up high current paths can be added on the inner layers.

We recommend that the top layer, located closest to the modules, be used for the ground planes and divided into two parts as follow :

- primary ground part, divided into two sub-parts (see KG9501 datasheet for further information)
- secondary ground parts,

Both parts must be as large as possible and spread out over the entire surface of the board; a grid could be used to avoid a complete copper surface.

GAIA Converter recommend the use of a decoupling common mode noise capacitance (10nF) between primary and secondary ground planes. If more than one module is used, additional common mode noise capacitance are recommended.

The «case» pin of the modules (if available) can be connected either to primary or secondary ground plane and a 6 sides shielding can be achieved with the PCB ground plane.

### 5-2 Component and Trace Routing Design

The component placement is also a key factor between a good result and a nightmare.

The first step in placing the component is to determine the power flow through the board. The most popular flow structure is from one side of the board to the other and avoiding cross-overs.

If more than one DC/DC modules is used it is recommended to place the modules side-by-side so that the power signals can be easily routed avoiding cross-overs. It is also recommended to leave 1/2 inch between each module to avoid that radiation from power stage of one module can affect the control stage of the adjacent module and cause cross-talk.

The second step is to place the EMI filter (KG9501 or other) next and as close as possible to the modules minimizing trace lengths to avoid «antenna» phenomenon and minimize loop areas and straight inductances that can limit the effectiveness of the filter. When placing these components make sure to leave enough room for power carrying traces to run through. Please consult also KG9501 datasheet for additional routing information.

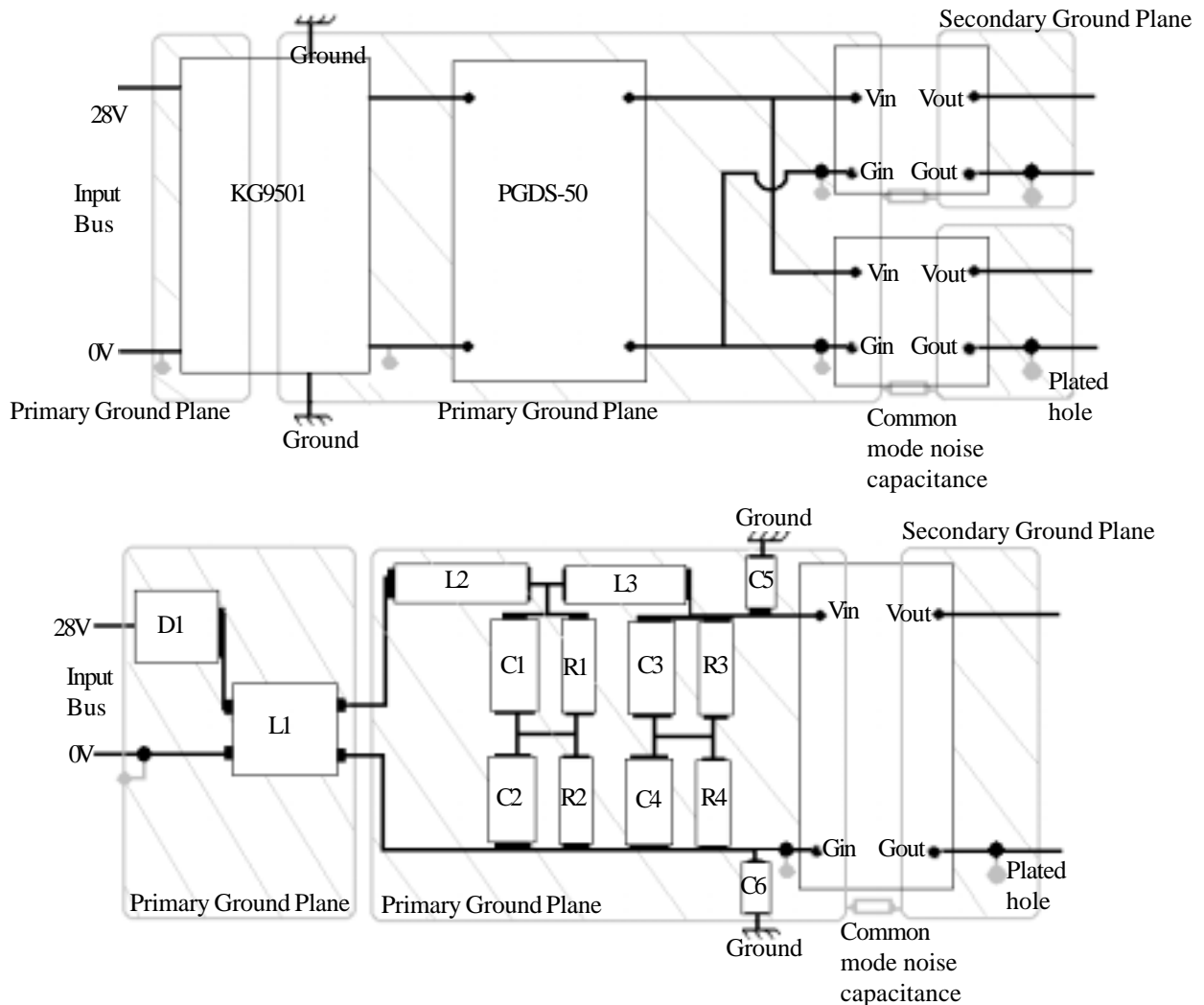

## 6- Emission Level CE03 Results

### 6-1 Emission Level CE03 Results with Single Module

Single module without filter

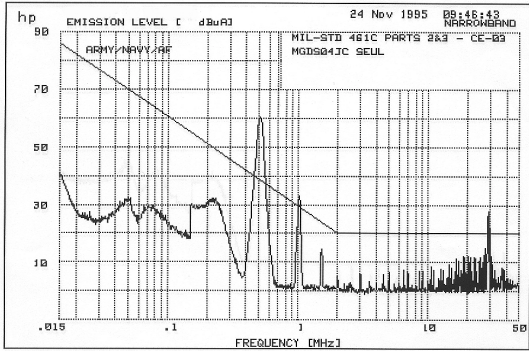

(MGDS-04-J-C module)

Single module with front filter KG9501

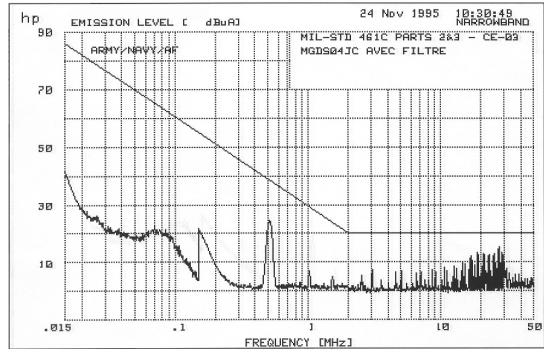

(MGDS-04-J-C module)

Single module without filter

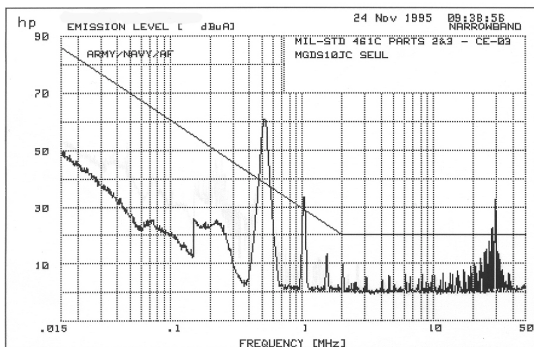

(MGDS-10-J-C module)

Single module with front filter KG9501

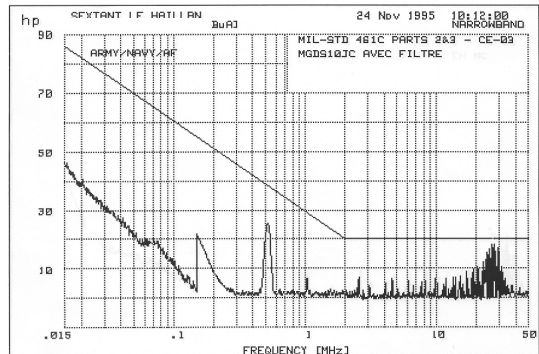

(MGDS-10-J-C module)

### 6-2 Emission Level with Multiple Module Architecture Filtered by KG9501

Module architecture stand alone

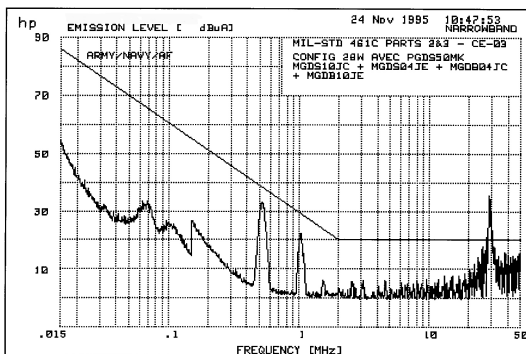

Module architecture with front filter KG9501

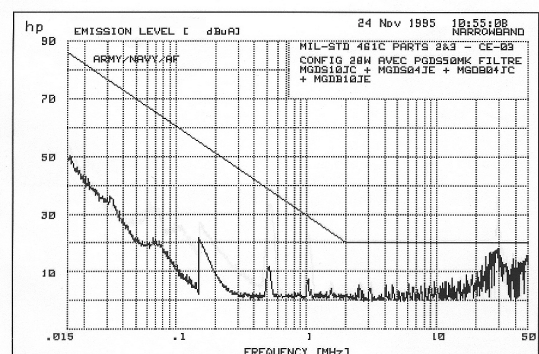



For more detailed specifications and applications information, contact :

<b>International Headquarters</b>	<b>North American Headquarters</b>
Marketing and Sales department GAIA Converter - France Address : B.P. 26 - 33186 LE HAILLAN - FRANCE Tel. : + (33)-5-57-92-12-80 Fax : + (33)-5-57-92-12-89	GAIA Converter Canada, Inc Address : 6611 Thimens ST-LAURENT, QUEBEC - CANADA H4S 1W2 Tel. : (514)-333-3169 Fax : (514)-333-4519

Represented by :