

## KM93C46

## CMOS EEPROM

## 1K Bit Serial Electrically Erasable PROM

## FEATURES

- Operating temperature range
  - KM93C46: Commercial
  - KM93C46I: Industrial
- Single 5 Volt supply
- High performance advanced CMOS technology
  - Reliable floating gate technology
- 64 × 16 serial read/write memory
- TTL compatible
- Low power dissipation
  - Standby current: 250 $\mu$ A (TTL)
  - Active current: 3 mA (TTL)
- Self-timed programming cycle
- Device status signal during programming
- 100,000 Cycle Endurance
- Available in plastic DIP and SOP

## GENERAL DESCRIPTION

The KM93C46 is a CMOS 5V. Only 1,024 bit non-volatile, sequential EEPROM. It is fabricated with the well defined floating gate CMOS technology using Fowler-Nordheim tunneling for erasing and programming.

The KM93C46 is organized as 64 registers of 16 bits each, which can be read/written serially by a microprocessor. It operates in a self-timed mode with the DO pin indicating the READY/BUSY status of the device.

The KM93C46 is designed for applications up to 100,000 erase/write cycles per word and over 10 years of data retention.

2

## FUNCTIONAL BLOCK DIAGRAM

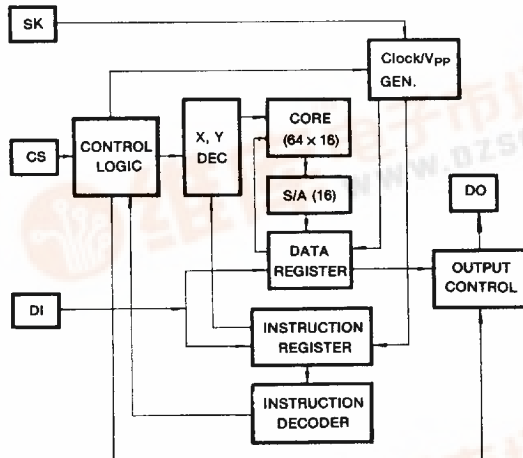

## PIN CONFIGURATION

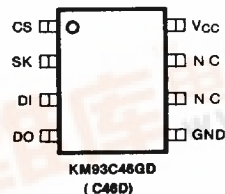
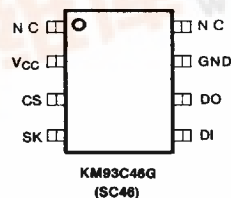
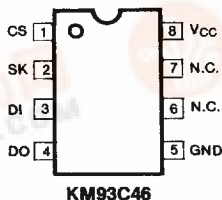

Pin Name	Pin Function
CS	Chip Select
SK	Serial Data Clock
DI	Serial Data Input
DO	Serial Data Output
N.C.	No Connection
Vcc	Power Supply
GND	Ground

**KM93C46****CMOS EEPROM****ABSOLUTE MAXIMUM RATINGS\***

Item	Symbol	Rating	Unit	
Voltage on Any Pin Relative to $V_{SS}$	$V_{IN}$	-0.3 to 7.0	V	
Temperature Under Bias	Commercial	$T_{bias}$	-10 to +125	°C
			Industrial	
Storage Temperature	$T_{stg}$	-65 to +150	°C	

\*Permanent device damage may occur if ABSOLUTE MAXIMUM RATINGS are exceeded. Functional operation should be restricted to the conditions as detailed in the operational sections of the data sheet. Exposure to absolute maximum rating conditions for extended periods may affect device reliability.

**RECOMMENDED OPERATING CONDITIONS**

KM93C46  $T_A = 0$  to  $70^\circ\text{C}$ , Voltages referenced to  $V_{SS}$   
 KM93C46I  $T_A = -40$  to  $85^\circ\text{C}$ , Voltages referenced to  $V_{SS}$

Item	Symbol	Min	Typ	Max	Unit
Supply Voltage	$V_{CC}$	4.5	5.0	5.5	V
Supply Voltage	$V_{SS}$	0	0	0	V

**DC CHARACTERISTICS**

(Recommended operating conditions unless otherwise noted)

Parameter	Symbol	Test Condition	Min	Max	Unit
Operating Voltage	$V_{CC}$		4.5	5.5	V
Operating Current (DC)	$I_{CC1}$	$V_{CC} = 5.5\text{V}$ , $CS = 2.0\text{V}$ , $SK = 2.0\text{V}$		1	mA
Operating Current (AC)	$I_{CC2}$	$V_{CC} = 5.5\text{V}$ , $f_{SK} = 1\text{MHz}$		3	mA
Standby Current (TTL)	$I_{SB1}$	$V_{CC} = 5.5\text{V}$ , $CS = 0.8\text{V}$		250	$\mu\text{A}$
Standby Current (CMOS)	$I_{SB2}$	$V_{CC} = 5.5\text{V}$ , $CS = 0\text{V}$		100	$\mu\text{A}$
Input Voltage Levels	$V_{IL}$ $V_{IH}$		-0.3	0.8	V
			2.0	$V_{CC} + 0.3$	
Output Voltage Levels	$V_{OL}$ $V_{OH}$	$I_{OL} = 2.1\text{mA}$ $I_{OH} = -400\mu\text{A}$	2.4	0.4	V
Input Leakage Current	$I_{LI}$	$V_{IN} = 5.5\text{V}$		10	$\mu\text{A}$
Output Leakage Current	$I_{LO}$	$V_{OUT} = 5.5\text{V}$ , $CS = 0\text{V}$		10	$\mu\text{A}$

**INSTRUCTION SET FOR MODE SELECTION**

Instruction	SB	OP Code	Address	Data	Comment
READ	1	10	A5A4A3A2A1A0	$D_{OUT}$	Read register A5A4A3A2A1A0
WRITE	1	01	A5A4A3A2A1A0	D15-D0	Write register A5A4A3A2A1A0
ERASE	1	11	A5A4A3A2A1A0	—	Erase register A5A4A3A2A1A0
EWEN	1	00	11XXXX	—	Erase/Write enable
EWDS	1	00	00XXXX	—	Erase/Write disable
ERAL	1	00	10XXXX	—	Erase all registers
WRAL	1	00	01XXXX	D15-D0	Write all registers

The KM93C46 provides 7 instructions as shown. Note that all the instructions start with a logic "1" start bit, and following 8 bits carry the OP code and the 6-bit address for 1 of 64, 16-bit registers.

**KM93C46**

**CMOS EEPROM**

**AC TEST CONDITIONS**

Parameter	Value
Input Pulse Levels	0.45V to 2.4V
Input Rise and Fall Times	20ns
Input and Output Timing measurement Levels	0.8V and 2.0V
Output Load	1 TTL Gate and $C_L = 100pF$

**AC OPERATING CHARACTERISTICS**

KM93C46  $T_A = 0^\circ C$  to  $70^\circ C$ ,  $V_{CC} = 5V \pm 10\%$ , unless otherwise noted.

KM93C46I  $T_A = -40^\circ C$  to  $85^\circ C$ ,  $V_{CC} = 5V \pm 10\%$ , unless otherwise noted.

Parameter	Symbol	Test Condition	Min	Max	Unit
SK Frequency	$f_{SK}$		—	1.0	MHz
SK High Time	$t_{SKH}$	(Note 1)	500		ns
SK Low Time	$t_{SKL}$	(Note 1)	250		ns
Chip Select Setup Time	$t_{CSS}$		50		ns
Chip Select Hold Time	$t_{CSH}$		0		ns
Data Setup Time	$t_{DIS}$		150		ns
Data Hold Time	$t_{DIH}$		150		ns
Output High Delay Time	$t_{PD1}$	$V_{OL} = 0.8V, V_{OH} = 2.0V$		500	ns
Output Low Delay Time	$t_{PDO}$	$V_{IL} = 0.45V, V_{IH} = 2.4V$		500	ns
Self-Timed Program Cycle Time	$t_{EW}$			10	ms
Min CS Low Time	$t_{CS}$	(Note 2)	250		ns
Rising Edge of CS to Status Valid	$t_{SV}$			500	ns
Falling Edge of CS to $D_{OUT}$ High-Z	$t_{OH}, t_{IH}$			100	ns

Note 1: The SK frequency spec, specifies a minimum SK clock period of  $1\mu s$ , therefore in a SK clock cycle  $t_{SKH} + t_{SKL}$  must be greater than or equal to  $1\mu s$ .

e.g., if  $t_{SKL} = 250ns$  then the minimum  $t_{SKH} = 750ns$  in order to meet the SK frequency specification.

Note 2: CS must be brought low for a minimum  $250ns(t_{CS})$  between consecutive instruction cycles.

**TIMING DIAGRAMS**  
**SYNCHRONOUS DATA TIMING**

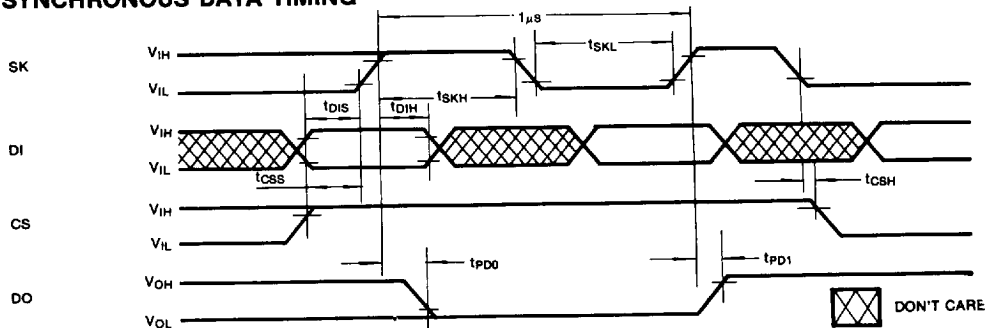

2

**KM93C46**

**CMOS EEPROM**

**TIMING DIAGRAMS (Continued)**

INSTRUCTION TIMING

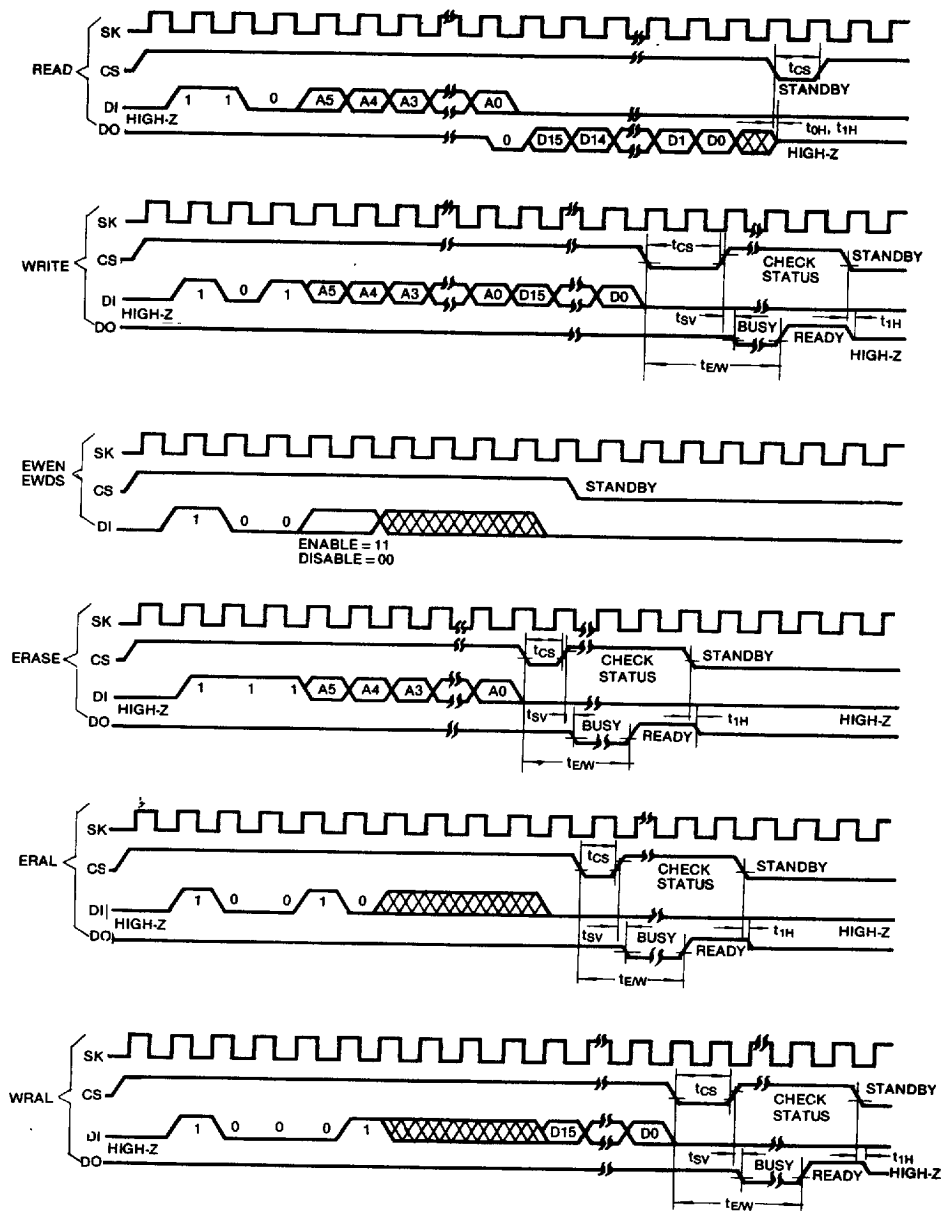

## KM93C46

## CMOS EEPROM

### DEVICE OPERATION

The KM93C46 is a 1K bit CMOS serial I/O EEPROM used with microcontrollers for non-volatile memory applications. The on-chip programming voltage generator allows user to use a single 5V power supply. The erase and write cycle of the KM93C46 is self-timed with the ready/busy status of the chip indicated at the DO pin. All the operations of the chip are preceded by two OP code bits, facilitating inherent protection against false writes. The DO pin is high-Z except for the read period and the ready/busy indication period to eliminate bus contention.

#### READ

After a read instruction and address set is received, low to high transition of the SK clock produces output data at DO pin. A dummy bit (logical '0') proceeds the 16 bit data output string.

#### EWEN / EWDS

The KM93C46 is at the erase/write disable (EWDS) state during the power-up period to protect against accidental disturbance. After the power up period, the erase/write operation must be preceded by an erase/write enable (EWEN) operation. The erase/write enable (EWEN) mode is maintained until an erase/write disable (EWDS) operation is executed or  $V_{CC}$  is removed from the part. Execution of the READ operation is independent of both EWEN and EWDS instructions

#### ERASE

Before a write cycle, an erase cycle need to be operated to reset the EEPROM cells to the 'erase' state. The chip starts the self-timed erase cycle by dropping CS low after an erase instruction and address set is input. The chip's ready/busy status is indicated at the DO pin by bringing CS high during erase cycle

#### WRITE

The write operation is started by sequentially loading its instruction, address, and data set. After the last bit of data is input on the DI pin, CS must be brought low before the rising edge of the SK clock. This falling edge of CS initiates the self-timed write cycle. Like the erase operation, write cycle has the ready/busy function.

#### ERAL (chip erase)

Entire memory array is erased, i.e., logical '1' state, by this chip erase (ERAL) operation. The chip erase cycle is identical to the erase cycle except for different OP code.

#### WRAL (chip write)

The entire array needs to be erased before this chip write mode operation. Data given during this mode are written to all cells in the corresponding column simultaneously

#### READY / BUSY

The ready/busy status of the KM93C46 during all the self-timed programming cycle (erase, write, chip erase, chip write) is indicated at the DO pin. Bringing the CS pin high, after self-timed programming cycle has been initiated, will produce logic '0' at the DO pin if the chip is still programming and a logic '1' if the programming cycle has been completed.

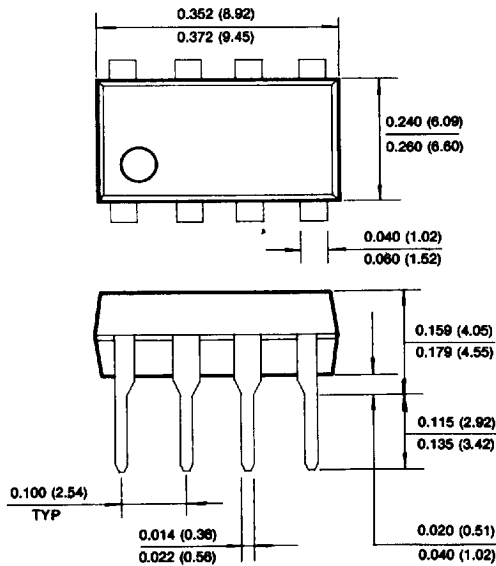
**KM93C46****CMOS EEPROM****PACKAGE DIMENSIONS**  
**8 PIN PLASTIC DUAL IN LINE PACKAGE**

unit: inches (millimeters)

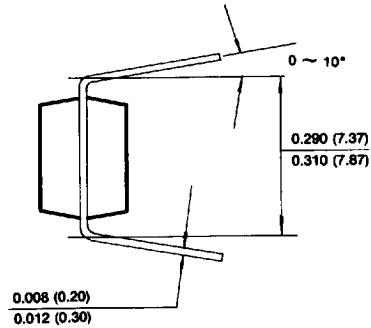
**8 PIN PLASTIC SMALL OUT LINE PACKAGE**