

cosmo

High Reliability Photocoupler KMOC3052

UL 1577 (File No.E169586) VDE EN60747-5-2 / EN60950 / EN60065 (File No.40009235)

Features

1. Compact dual-in-line package.
2. 600V peak blocking voltage.
3. Isolation voltage between input and output (Viso:5000Vrms).

For 115/240 Vac (rms) Application:

1. Solenoid/Valve Controls.
2. Lighting Controls.
3. Static Power Switches.
4. AC Motor Drives.
5. Temperature Controls.
6. E. M. Contactors.
7. AC Motor Staters.
8. Solid State Relays.
9. Programmable controllers.

Outside Dimension:Unit (mm)

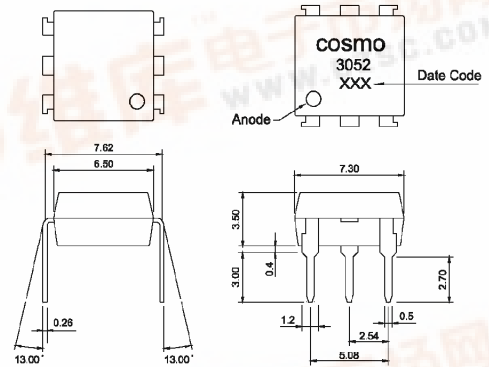

Schematic:Top View

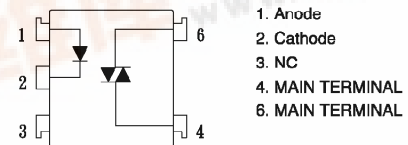

Absolute Maximum Ratings

(Ta=25°C)

Parameter	Symbol	Rating	Unit
Input	Forward current	IF	50 mA
	Peak forward current (100us)	IFM	1 A
	Reverse voltage	VR	6 V
	Power dissipation	PD	70 mW
Output	Off-State Output Terminal voltage	VDRM	600 Vpeak
	On-State R. M. S. Current	IT(RMS)	100 mA
	Peak Repetitive Surget Current (PW=10ms, DC 10%)	ITSM	1 A
	Power dissipation	PD	300 mW
	Total power dissipation	Ptot	330 mW
	Isolation voltage 1 minute	Viso	5000 Vrms
Operating temperature	Topt	-40 to +85 °C	
Storage temperature	Tstg	-50 to +125 °C	
Soldering temperature 10 second	Tsol	260 °C	

Electro-optical Characteristics

(Ta=25°C)

Parameter	Symbol	Conditions	MIN.	TYP.	MAX.	Unit	
Input	Forward voltage	VF	—	1.2	1.4	V	
	Peak forward voltage	VFM	—	—	3.5	V	
	Reverse Leakage Current	IR	VR=4V	—	—	10 μA	
Output	Peak Blocking Current	IDRM	—	—	100	nA	
	ON-State Voltage	VTM	—	1.6	2.8	V	
Transfer characteristics	Holding Current	IH	—	1.0	—	mA	
	Critical rate of rise of OFF-state voltage	dV/dt	—	—	—	V/μS	
	Isolation resistance	Riso	DC500V	5x10 ¹⁰	10 ¹¹	—	ohm
	Minimum trigger current	IFT	Main Terminal Voltage=3V	—	—	10	mA
	Turn-on time	Ton	Vd=6V, RL=100 ohm, IF=20mA	—	—	100	μS



