

Kingbright

Part NO. :KRB031

PCB TYPE PHOTOINTERRUPTER

*Dimensions

Note:All units are in millimeters unless otherwise indicated.

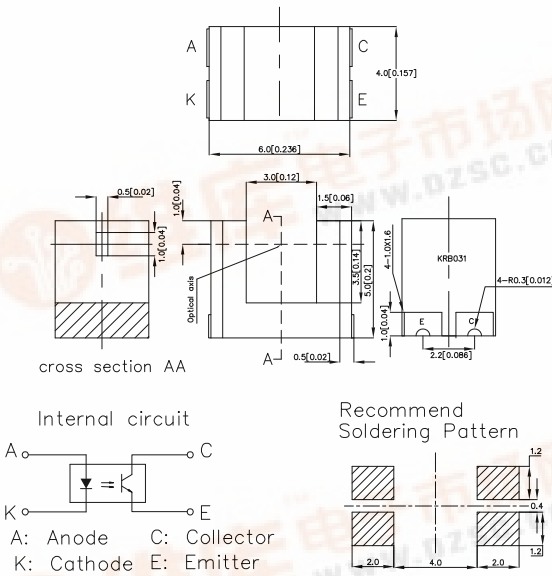

*Features

- Ultra-compact with a 6.0mm width photointerrupter and 3mm width slot.
- PCB surface mounting type.
- High resolution with a 0.5mm width aperture.

*Absolute Maximum Ratings (Ta=25°C)

Parameter		Symbol	Rating	Unit
Input	Forward current[1]	IF	25	mA
	Reverse voltage	VR	5	V
	Power dissipation	Pd	35	mW
Output	Collector-emitter voltage	VCEO	20	V
	Emitter-collector voltage	VECO	5	V
	Collector current	IC	20	mA
	Collector power dissipation	PC	75	mW
Operating temperature		Topr	-30~+85	°C
Storage temperature		Tstg	-40~+90	°C
Soldering temperature[2]		Tsol	240	°C
Manual soldering[2]		Tsol	300	°C

Unless otherwise, the tolerances are ±0.15mm.

Notes:1.Refer to the temperature ratingchart if the ambient temperature exceeds 25°C.

2.Complete soldering within 10 seconds for reflow soldering and within 3 seconds for manual soldering.

*Electrical / Optical Characteristics at Ta=25°C

Parameter	Symbol	Value			Conditions	
		Min.	Typ.	Max.		
Input	Forward voltage	VF	-	1.1V	1.3V	IF=5mA
	Reverse current	IR	-	-	10µA	VR=5V
	Peak Wavelength	λp	-	940nm	-	IF=20mA
Output	Collector current	IC	50µA	150µA	-	IF=5mA, VCE=5V
	Collector dark current	ID	-	-	100nA	VCE=10V, 0LX
	Collector-emitter saturation voltage	VCE(sat)	-	0.1V	0.4V	IC=50µA, IF=20mA
	Peak spectral sensitivity wavelength	λp	-	920nm	-	-
Rise time	tr	-	8µsec	-	VCC=5V, RL=1KΩ IC=100µA	
Fall time	tf	-	10µsec	-		



Fig.1 Forward Current vs. Forward Voltage

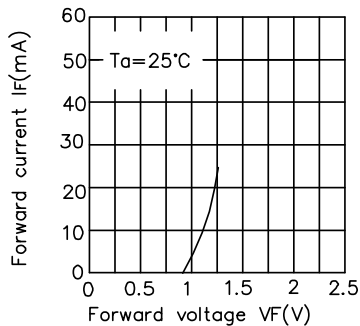

Fig.2 Collector Current vs. Forward Current

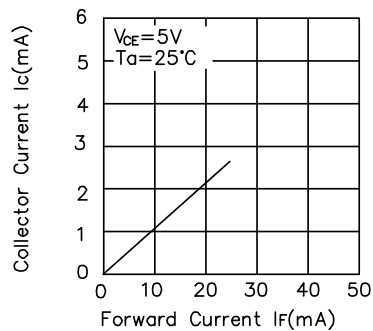

Fig.3 Collector Current vs. Ambient Temperature

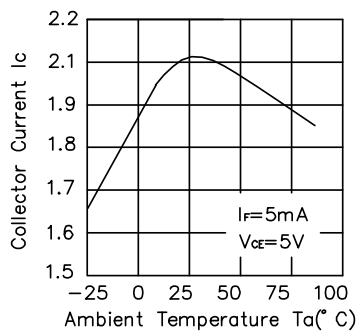

Fig.4 Collector-Emitter Saturation Voltage vs. Ambient Temperature

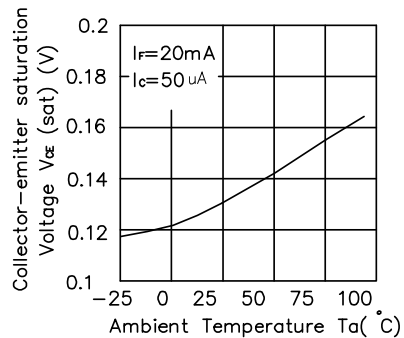

Fig.5 Forward Current vs. Collector Dissipation Temperature Rating

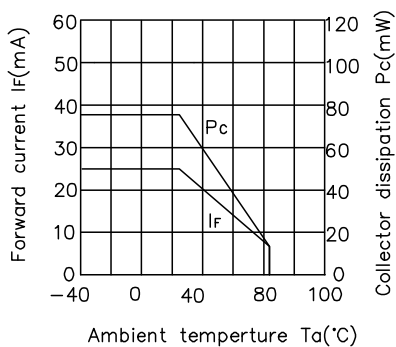

Fig.6 Forward Current vs. Collector-Emitter Voltage

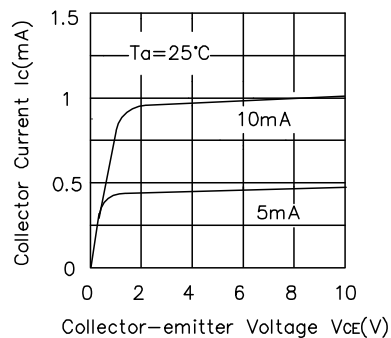

Fig.7 Relative Collector Current vs. Shield Distance(1) Fig.8 Relative Collector Current vs. Shield Distance(2)

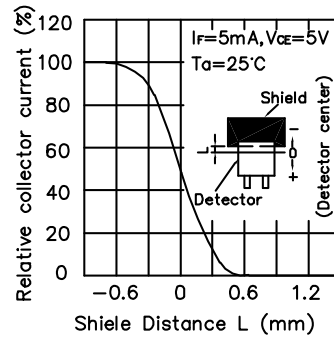
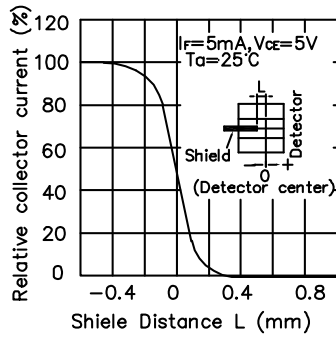
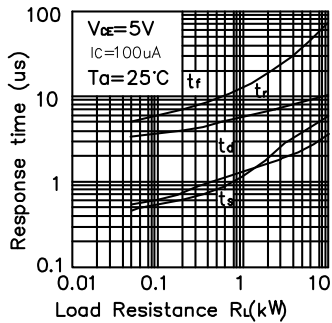
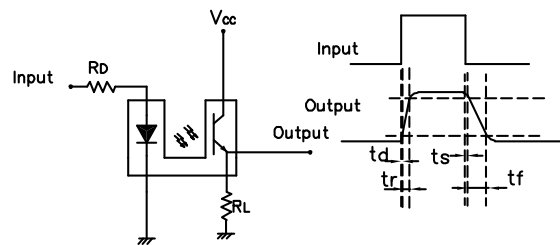

Fig.9 Response Time vs. Load Resistance



Test Circuit for Response Time



**Reel Dimensions
(Units : mm)**

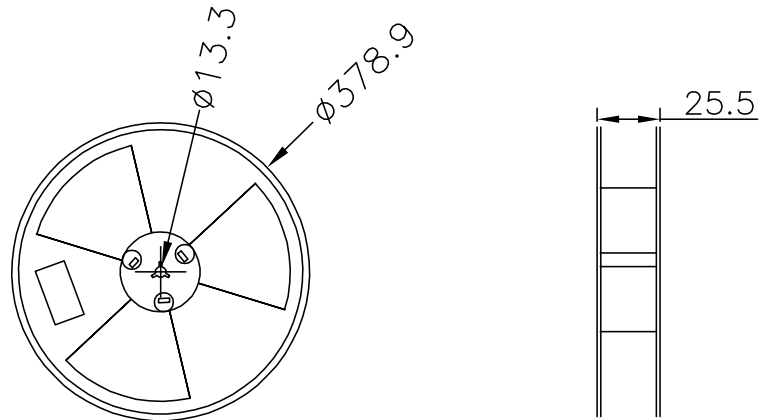

**Tape Specifications
(Units : mm)**

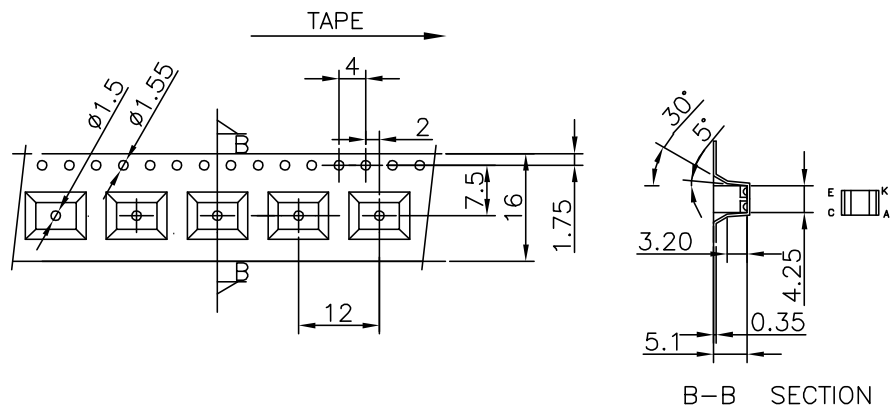

Tape quantity
1000pcs/reel