

SWITCHING APPLICATION.  
AUDIO MUTING APPLICATION.  
INTERFACE CIRCUIT AND DRIVER  
CIRCUIT APPLICATION.

### FEATURES

- With Built-in Bias Resistors.
- Simplify Circuit Design.
- Reduce a Quantity of Parts and Manufacturing Process.

### EQUIVALENT CIRCUIT

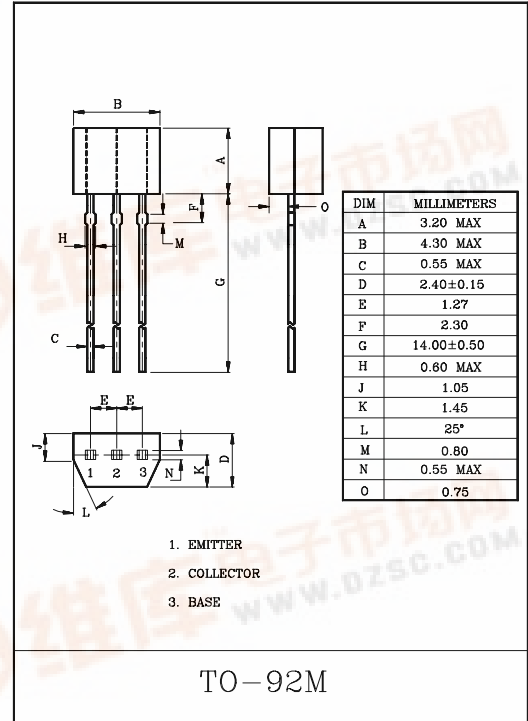
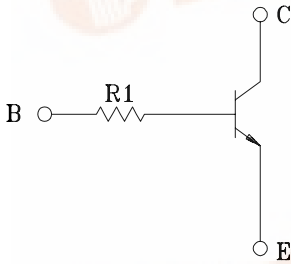

### MAXIMUM RATINGS(Ta=25°C)

CHARACTERISTIC	SYMBOL	RATING	UNIT
Collector-Base Voltage	$V_{CBO}$	30	V
Collector-Emitter Voltage	$V_{CEO}$	15	V
Emitter-Base Voltage	$V_{EBO}$	5	V
Collector Current	$I_C$	600	mA
Collector Power Dissipation	$P_C$	400	mW
Junction Temperature	$T_j$	150	°C
Storage Temperature Range	$T_{stg}$	-55~150	°C

# KRC231M ~ KRC233M

## ELECTRICAL CHARACTERISTICS (Ta=25°C)

CHARACTERISTIC		SYMBOL	TEST CONDITION	MIN.	TYP.	MAX.	UNIT
Collector-Emitter Breakdown Voltage		$BV_{CEO}$	$I_C=1mA$	15	-	-	V
Collector-Base Breakdown Voltage		$BV_{CBO}$	$I_C=50\mu A$	30	-	-	V
Emitter-Base Breakdown Voltage		$BV_{EBO}$	$I_E=50\mu A$	5.0	-	-	V
Collector Cut-off Current		$I_{CBO}$	$V_{CB}=30V$	-	-	0.5	$\mu A$
Collector-Emitter Saturation Voltage		$V_{CE(sat)}$	$I_C=50mA, I_B=2.5mA$	-	40	80	mV
DC Current Gain		$h_{FE}$	$V_{CE}=5V, I_C=50mA$	200	350	800	-
Input Resistor	KRC231M	$R_i$		-	2.2	-	k $\Omega$
	KRC232M			-	5.6	-	
	KRC233M			-	10	-	
Transition Frequency		$f_T^*$	$V_{CE}=10V, I_E=-50mA, f=100MHz$	-	200	-	MHz
On Resistance		$R_{on}$	$f=1kHz, I_B=1mA, V_{IN}=0.3V$	-	0.6	-	$\Omega$

Note : \*Characteristic of Transistor Only

# KRC231M ~ KRC233M

