

KS58550

UNIVERSAL 10 MEMORY DIALER

INTRODUCTION

The KS58550 is 10 memory Tone/pulse switchable dialer with 32 digit redial memory.

The Flash time is selectable on the keyboard.

Also, Hands-Free and Hold function are controlled on the keyboard. The KS58550 can fulfill all the standards of each country.

FEATURES

- Flash Time selectable on the keyboard (92, 312, 608 mS)
- Hands-Free and Hold function
- Key in Tone function (1.75KHz)
- Tone/Pulse switchable
- Pulse rate selectable
- Make/Break ratio selectable
- Single tone enable for test
- Uses 3.579545MHz Color burst Crystal or ceramic resonator
- Tone (T/ *) key function (Pulse → Tone)
- Redial function (Pulse: 32 digit, Tone : 31 digit)
- Two touch repertory memory (Pulse : 16 digit, Tone : 15 digit)
- Pin compatible with KS58006, KS58555B

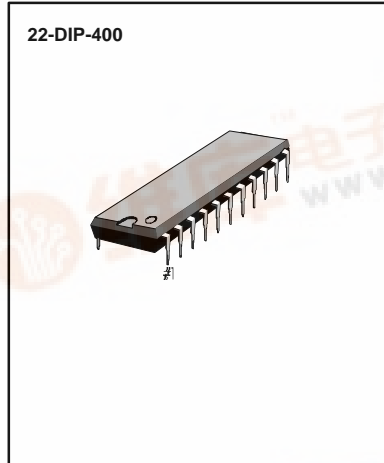

ORDERING INFORMATION

Device	Package	Function					
		HFD	HOLD	KIT	FLASH TIME	MAKE/BREAK	PPS
KS58550	22-DIP-400	O	O	O	Selectable	Selectable	Selectable

* HFD : Hands-Free Dialing Function

* HOLD : Hold for Melody

* KIT : Key In Tone

SAMSUNG

ELECTRONICS

BLOCK DIAGRAM

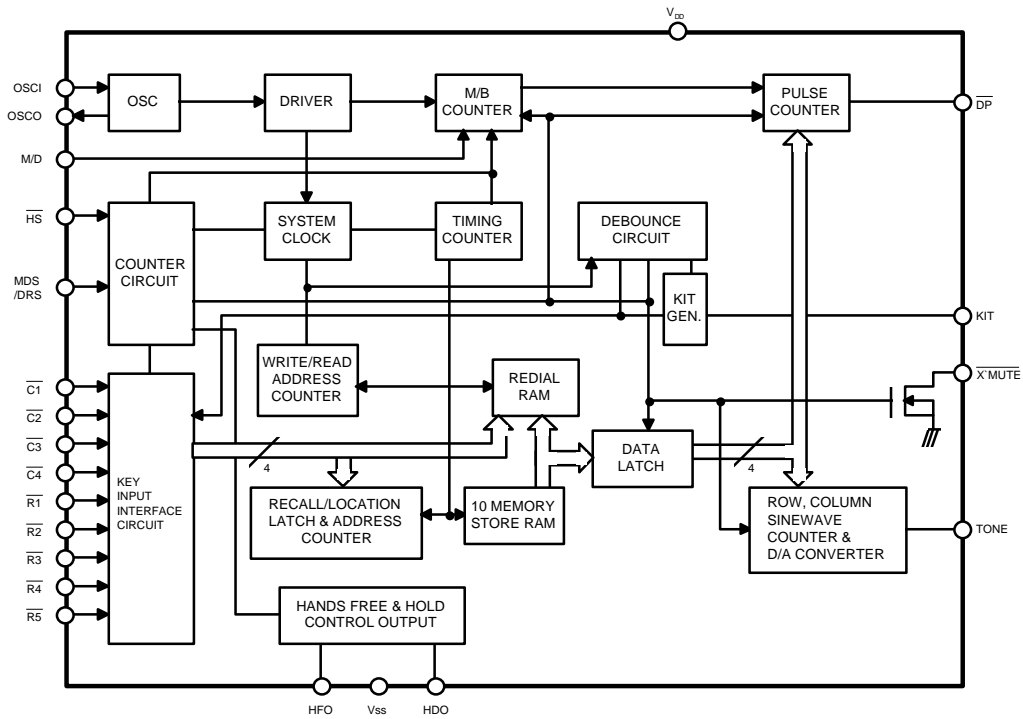

KS58550

UNIVERSAL 10 MEMORY DIALER

PIN CONFIGURATION

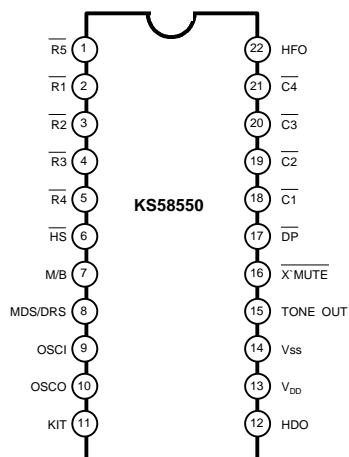

ARRANGEMENT OF KEY BOARD

1	2	3	ST
4	5	6	R/L
7	8	9	RD/P
T/*	0	#	F3
HFI	HDI	F1	F2

- RD/P: Redial/Pause
- ST : Store
- R/L : Recall/Location
- F1 : Flash Time (92ms)
- F2 : FlashTime (312ms)
- F3 : Flash Time (608ms)
- HFI : Hands Free Dialing Key Input
- HDI : Hold Key Input
- T/* : Pulse → Tone Mode
- # : RD/P Function in Pulse Mode
Data in Tone Mode

SELECTION FUNCTION

PIN	CONNECTION	FUNCTION
MDS/DRS	V _{DD}	PULSE MODE/20 PPS
	OPEN	PULSE MODE/10 PPS
	V _{SS}	TONE MODE
MAKE/BREAK	V _{DD}	1 : 2 (M : B)
	V _{SS}	2 : 3 (M : B)



PIN DESCRIPTION

Pin No	Symbol	I/O	Description
1	$\overline{R5}$	I	Row Key Input
2	$\overline{R1}$		
3	$\overline{R2}$		
4	$\overline{R3}$		
5	$\overline{R4}$		
6	\overline{HS}	I	Hook Switch
7	M/B	I	Make/Break Select
8	MDS/DRS	I	Mode & Dial Pulse Ratio Select Pin
9	OSCI	I	Oscillator Input
10	OSCO	O	Oscillator Output
11	KIT	O	Key - In -Tone Output
12	HDO	O	Hold Function Control Output
13	V _{DD}	S	(+) Power
14	V _{SS}	S	(-) Power
15	TONE	O	Tone Output
16	$\overline{X'MUTE}$	O	Xmute Output (N - Channel Open Drain)
17	DP	O	Dial Pulse Output (CMOS Inverter Output)
18	$\overline{C1}$	I	Column Key Input
19	$\overline{C2}$		
20	$\overline{C3}$		
21	$\overline{C4}$		
22	HFO	O	Hands-Free Control Output

ABSOLUTE MAXIMUM RATINGS

Characteristic	Symbol	Value	Unit
Supply Voltage	V _{DD}	- 0.3 ~ 7.0	V
Input Voltage	V _I	- 0.2 ~ V _{DD} + 0.3	V
Output Voltage	V _O	- 0.3 ~ V _{DD} + 0.3	V
Power Dissipation	P _D	500	mW
Operating Temperature	T _{OPR}	- 20 ~ + 70	°C
Storage Temperature	T _{STG}	- 55 ~ + 150	°C

ELECTRICAL CHARACTERISTICS(V_{DD} = 3.5V, V_{SS} = 0V, Ta = 25°C, f_{osc} = 3.579545 MHz)

Characteristic	Symbol	Test Conditions	Min	Typ	Max	Unit	
Operating voltage	V _{DD}	-	2.0	-	6.0	V	
Memory Retention Voltage	V _{MR}	-	1.0	-	-		
Memory Retention Current	I _{MR}	HS = V _{DD} = 1.0V	-	0.05	0.1	μA	
Operating Current	I _{DD(PULSE)}	All Output Unloaded	Pulse Mode	-	0.1	0.3	mA
	I _{DD(TONE)}		Tone Mode	-	0.4	0.7	
Standby Current	I _{SB}	HS = V _{SS}	-	10	50	μA	
Output Sink Current (DP, X'MUTE)	I _{O(SINK)1}	V _{OL} = 0.4V	1.7	5.0	-	mA	
	I _{O(SINK)2}	V _{OL} = 0.4V, V _{DD} = 2.5V	0.5	1.5	-	mA	
Output Current	I _{OH}	V _{OH} = 3.0V	1.8	5.2	-	mA	
	I _{OL}	V _{OL} = 0.4V	1.7	5.1	-	mA	
Input Voltage	V _{IH}	R1 ~ R5, M/B, HS	0.8V _{DD}	-	V _{DD}	V	
	V _{IL}	C1 ~ C4, MDS/RDS, HS	V _{SS}	-	0.2V _{DD}	V	
Input Current	V _{I1}	R1 ~ R5, V _{IN} = V _{SS}	-	-	50	μA	
	V _{I2}	R1 ~ R5, V _{IN} = V _{SS} V _{DD} = 2.5V	-	-	30	μA	
Column to Row Tone Ratio	dBcr	Tone Mode	1	2	3	dB	
Row Tone Output	V _{OH(TONE)}	R _L = 5.0 Kohm	-18	-	-16	dBV	
	V _{OL(TONE)}	V _{DD} = 2.5V, R _L = 5.0Kohm	-18	-	-16		
Tone Distortion	THD	-	-	-	4	%	
Valid Key Entry Time	t _{KD}	-	-	23.0	-	mS	
Pause Time	t _{PA}	"P" Key Depress	-	3.52	-	Sec	
Pulse Interdigit Pause Time	t _{PIDP1}	MDS/DRS = V _{DD} (20 PPS)	-	585	-	mS	
	t _{PIDP2}	MDS/DRS = OPEN (10 PPS)	-	805	-		
Tone Interdigit Pause Time	t _{TIDP}	MDS/DRS = V _{SS}	-	92	-		
Tone Duration	t _{TD}	-	-	92	-		
Key In Tone Duration	t _{KIT}	-	-	27	-		
Key In Tone Frequency	f _{KIT}	-	-	1.75	-		
Make/Break Time	t _{MB}	MDS/DRS = OPEN (10PPS)	M/B = V _{DD}	-	34.33/68.66	-	KHz
			M/B = V _{SS}	-	41.19/61.79	-	
		MDS/DRS = V _{DD} (20PPS)	M/B = V _{DD}	-	17.16/34.33	-	mS
			M/B = V _{SS}	-	20.59/30.89	-	

ELECTRICAL CHARACTERISTICS(V_{DD} = 3.5V, V_{SS} = 0V, Ta = 25°C, f_{OSC} = 3.579545 MHz)

Characteristic	Symbol	Test conditions	Min	Typ	Max	Unit
Pulse to Tone Auto Pause Time	t _{PTPA}	-	-	3.52	-	Sec
Pre - digit Pause Time	t _{PDPA}	MDS/DRS = V _{DD} , M/B = V _{DD}	-	20	-	mS
		MDS/DRS = OPEN, M/B = V _{DD}	-	34	-	
		MDS/DRS = V _{DD} , M/B = V _{DD}	-	14	-	
		MDS/DRS = OPEN, M/B = V _{DD}	-	24	-	
Pulse to X'MUTE Overlap Time	t _{PMO}	-	-	1.2	-	mS
Flash Time	t _{FL}	F1 Key Depress	-	92	-	mS
		F2 Key Depress	-	312	-	
		F3 Key Depress	-	608	-	

APPLICATION INFORMATION KEY DESCRIPTION

- **1, 2, 3, 4, 5, 6, 7, 8, 9, 0**
These are Tone/Pulse dialing signal keys in normal mode.
- **T/***
Pulse Mode : Pulse to Tone Switching Key
Tone Mode : Data Key
- **#**
Pulse Mode : This Key will operate as a redial key if it is pressed first after off - hook.
Otherwise, it will be allowed as a pause key.
Tone Mode : Data key
- **ST: Store**
If the ST key is allowed when the dialer is set to the corresponding condition, pressing the ST key will change the dialer into the ST mode.
The ST mode is released after the memory transfer operation is executed.
The dialing sequence will be interrupted when the key is activated.
- **R/L**
This key will be allowed location selection in store mode and will be allowed recall function in normal mode.
- **F: Flash (i = 1, 2, 3)**
If the Flash key is pressed,
DP and X'MUTE will be forced to low during the t_{FL} (Flash Time)

F1	92mS	Flash Time Selectable on the Keyboard
F2	312mS	
F3	608mS	

• RD/P KEY

If press this key first after off - hook, it will operate as a redial key, otherwise it will operate as a pause key.

• HFI

Hands-Free dialing input.

Hands-Free dialing output is controlled on the keyboard (HFI)

• HDI

Hold function input.

Hold function is controlled on the keyboard (HDI).

The output will control the melody enable.

KEYBOARD AND SWITCHES OPERATION**• SYMBOL DEFINITION**

D_p = PULSE DATA : 0,1,2,3,4,5,6,7,8,9

D_t = TONE DATA : 0,1,2,3,4,5,6,7,8,9,*,#

D_g = STORE DATA : 0,1,2,3,4,5,6,7,8,9,*,#

D_n = INDIRECT MEMORY LOCATION : 0,1,2,3,4,5,6,7,8,9

REC = RECALL

LOC = LOCATION

ZiZiZi = Conversation Mode

OFF = OFF-HOOK

ON = ON-HOOK

= INPUT LEVEL LOW TO HIGH

= INPUT LEVEL HIGH TO LOW

• OPERATION MANUAL

- NORMAL DIALING IN PULSE MODE

OFF-HOOK : D_p, -, D_p, : ZiZiZi : ON-HOOK

- NORMAL DIALING IN TONE MODE

OFF-HOOK : D_t, -, D_t, : ZiZiZi : ON-HOOK

- NORMAL DIALING FROM PULSE TO TONE VIA T/* KEY

OFF-HOOK : D_p, -, D_p, T/*, D_t, : ZiZiZi : ON-HOOK

- NORMAL DIALING FROM PULSE TO TONE VIA MDS/DRS SWITCH

OFF-HOOK : D_p, -, D_p, MDS/DRS, ↓, D_t, -, D_t, : ZiZiZi : ON-HOOK

- REDIAL

OFF-HOOK : RD/P : ZiZiZi : ON-HOOK

(if the dialing digit exceeds 32 digits, the redialing operation will be inhibited)

- REPERTORY DIALING FOR ONE MEMORY

OFF-HOOK : R/L, D_m, : ZiZiZi : ON-HOOK

**ELECTRONICS**

- REPERTORY DIALING FOR CASCADED MEMORY
OFF-HOOK : R/L, Dm, : ZiZiZi : ON-HOOK (The cascade 32 digits dialing are available)
- NORMAL DIALING AFTER REDIALING
OFF-HOOK : RD/P, Dn, ----, Dn, : ZiZiZi : ON-HOOK
- NORMAL DIALING AFTER REPERTORY DIALING
OFF-HOOK : R/L, Dm, Dn ----, Dn, : ZiZiZi : ON-HOOK
- REPERTORY DIALING AFTER NORMAL DIALING
OFF-HOOK : Dn, ----, Dn, R/L, Dm, : ZiZiZi : ON-HOOK
- REPERTORY DIALING AFTER REDIALING
OFF-HOOK : RD/P, R/L, Dm, : ZiZiZi : ON-HOOK
- STORE FOR ONE MEMORY
OFF-HOOK / ON, ST, Dn, ----, Dn, R/L, Dm, : ON-HOOK
- STORE FOR CASCADE MEMORY
OFF-HOOK / ON, ST, Dn,-, Dn, R/L, Dm, ST, Dn, -, Dn, R/L, Dm : ON-HOOK
- HANDS FREE DIAL
ON-HOOK : HFI, D1, D2,-, Dn, HFI, RD
- HOLD FUNCTION
Melody output enable/disable function.

TRUTH TABLE OF HANDS FREE INPUT & HOLD FUNCTION

NO	CURRENT STATE			INPUT	NEXT STATE		
	HOOK STATE	HFO	HDO		HFO	HDO	DIALING
1	ON/OFF HOOK	L	L	HFI KEY IN	H	L	YES
2	ON HOOK	H	L	HFI KEY IN	L	L	NO
3	OFF HOOK	H	L	HFI KEY IN	L	L	YES
4	ON HOOK	X	X	OFF HOOK	L	L	YES
5	OFF HOOK	X	H	ON HOOK	P	P	MELODY ON
6	OFF HOOK	L	L	ON HOOK	L	L	NO
7	OFF HOOK	H	L	ON HOOK	H	L	YES
8	ON HOOK	L	X	HDI KEY IN	L	P	NO
9	ON HOOK	H	L	HDI KEY IN	H	H	MELODY ON
10	ON HOOK	H	H	HDI KEY IN	H	L	YES
11	OFF HOOK	X	L	HDI KEY IN	P	H	MELODY ON
12	OFF HOOK	X	H	HDI KEY IN	P	L	YES
13	ON/OFF HOOK	X	H	HDI KEY IN	P	H	MELODY ON

* Comment : X : Don't Care
P : Previous State



TONE GENERATOR

The device will be designed 15 Level, 30 Segment.

The COLUMN TONE is Pre-emphasized 2 dB than the ROW TONE.

In order to generate a single tone, push the same COLUMN or ROW keys more than 2 Keys at the same time.

TONE FREQUENCY

INPUT	SPECIFIED	ACTUAL	%ERROR
ROW1	697	699.1	+ 0.31
ROW2	770	766.2	- 0.49
ROW3	852	845.4	- 0.54
ROW4	941	948.0	+ 0.74
COLUMN1	1209	1215.9	+ 0.57
COLUMN2	1336	1331.7	- 0.33
COLUMN3	1477	1471.9	- 0.35

TIMING DIAGRAM

1) PULSE MODE

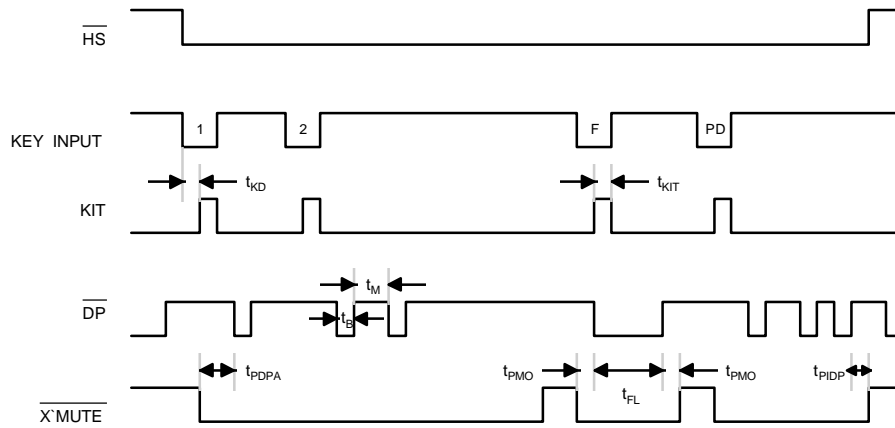

2) TONE MODE

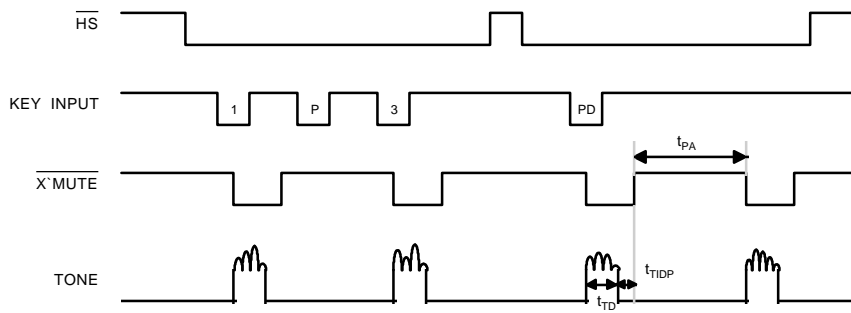

3) PULSE TO TONE DIALING

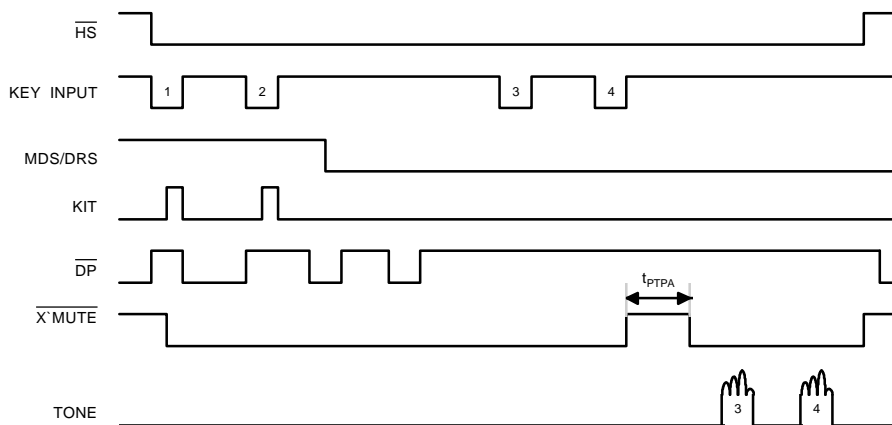

4) HANDS-FREE DIALING & HOLD FUNCTION

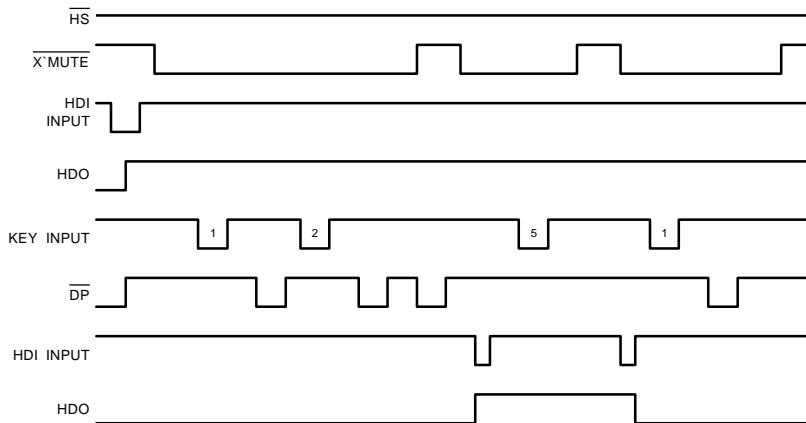

APPLICATION CIRCUIT

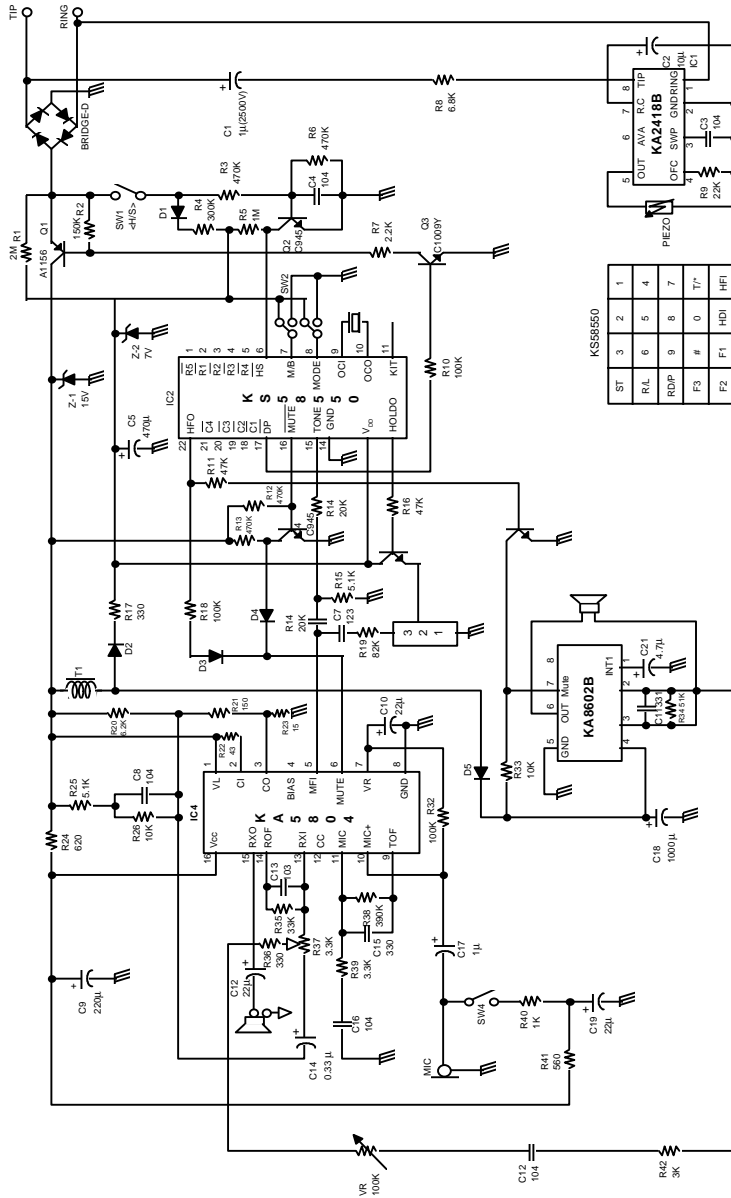

22-DIP-400

Dimensions in Millimeters/inches

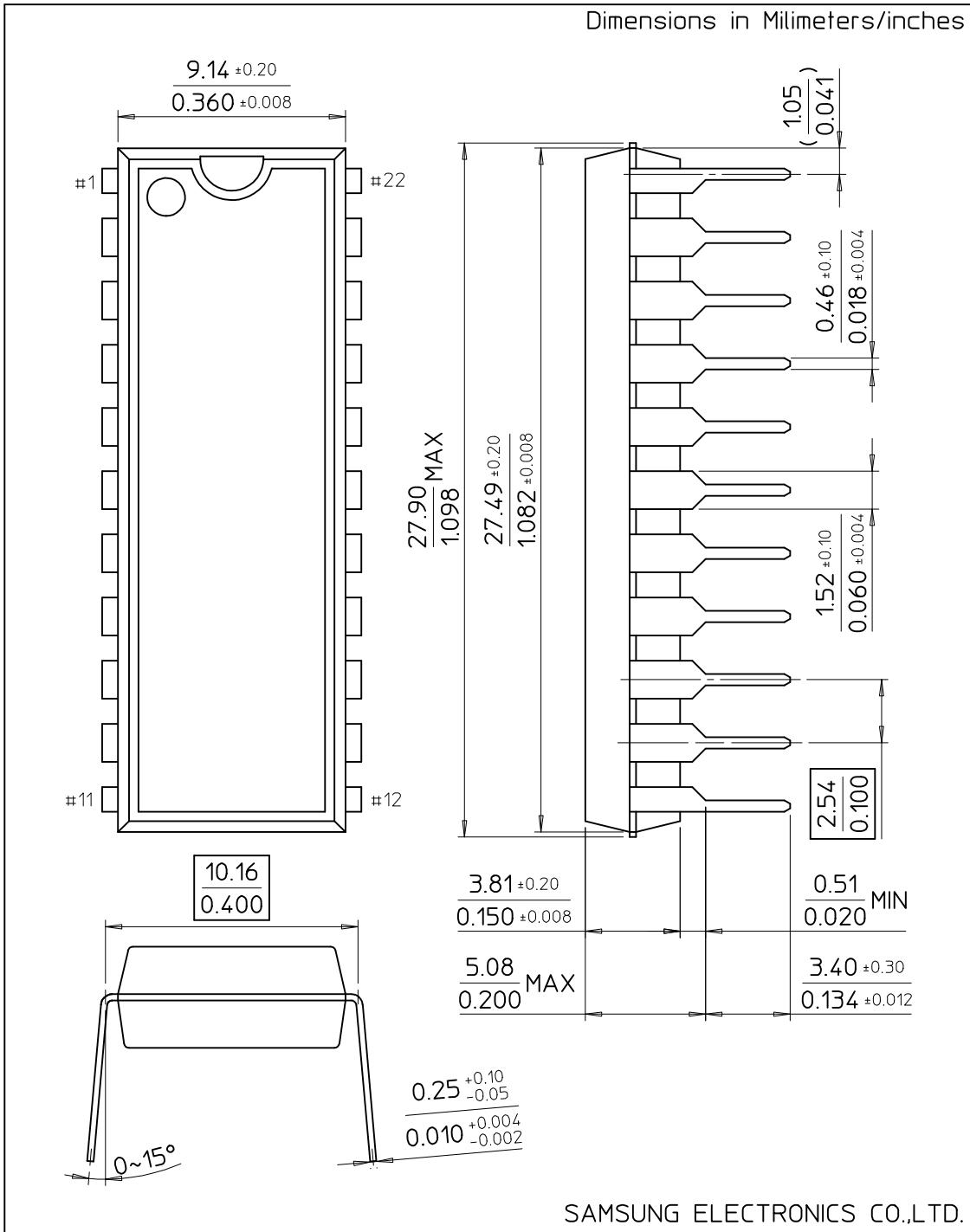

SAMSUNG ELECTRONICS CO.,LTD.