

GENERAL PURPOSE APPLICATION.
DPAK FOR SVRFACE MOUNT APPLICATIONS.

FEATURES

- Low Collector Saturation Voltage
: $V_{CE(sat)} = -1.0V(\text{Max.})$ at $I_C = -2A, I_B = -0.2A$.
- Straight Lead (IPAK, "L" Suffix)
- Complementary to KTC2020D/L.

MAXIMUM RATING (Ta=25°C)

| CHARACTERISTIC | | SYMBOL | RATING | UNIT |
|-----------------------------|---------|-----------|-----------|------|
| Collector-Base Voltage | | V_{CBO} | -60 | V |
| Collector-Emitter Voltage | | V_{CEO} | -60 | V |
| Emitter-Base Voltage | | V_{EBO} | -7 | V |
| Collector Current | | I_C | -3 | A |
| Base Current | | I_B | -0.5 | A |
| Collector Power Dissipation | Ta=25°C | P_C | 1.0 | W |
| | Tc=25°C | | 20 | |
| Junction Temperature | | T_j | 150 | °C |
| Storage Temperature Range | | T_{stg} | -55 ~ 150 | °C |

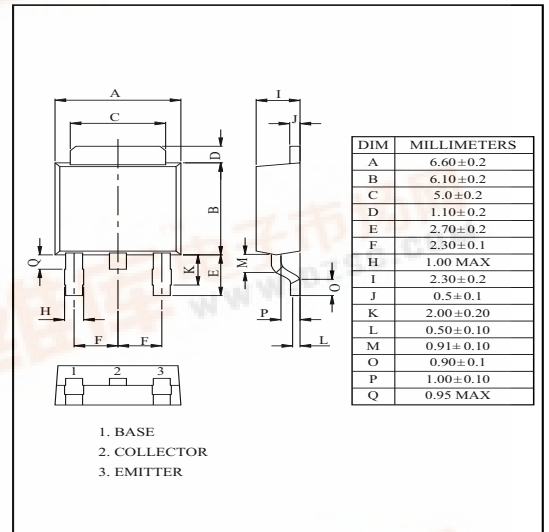

DPAK

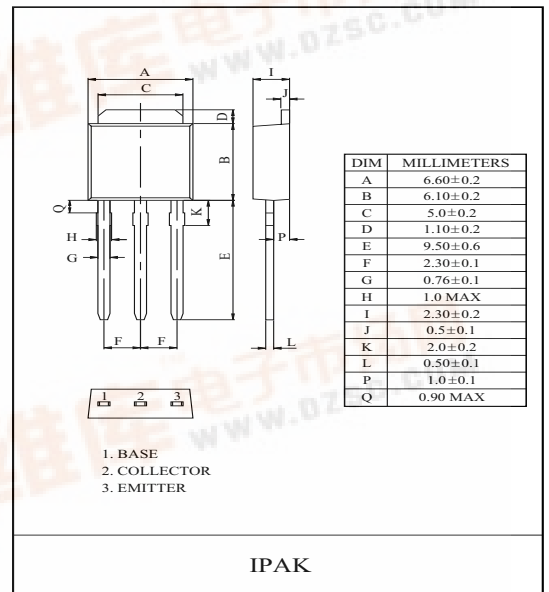

IPAK

ELECTRICAL CHARACTERISTICS (Ta=25°C)

| CHARACTERISTIC | | SYMBOL | TEST CONDITION | MIN. | TYP. | MAX. | UNIT |
|--------------------------------------|--------------|--------------------------|------------------------------------|------|-------|------|------|
| Collector Cut-off Current | | I_{CBO} | $V_{CB} = -60V, I_E = 0$ | - | - | -100 | μA |
| Emitter Cut-off Current | | I_{EBO} | $V_{EB} = -7V, I_C = 0$ | - | - | -100 | μA |
| Collector-Emitter Breakdown Voltage | | $V_{(BR)CEO}$ | $I_C = -50mA, I_B = 0$ | -60 | - | - | V |
| DC Current Gain | | $h_{FE(1)}(\text{Note})$ | $V_{CE} = -5V, I_C = -0.5A$ | 100 | - | 300 | |
| | | $h_{FE(2)}$ | $V_{CE} = -5V, I_C = -3A$ | 20 | - | - | |
| Collector Emitter Saturation Voltage | | $V_{CE(sat)}$ | $I_C = -2A, I_B = -0.2A$ | - | -0.25 | -1.0 | V |
| Base-Emitter Voltage | | V_{BE} | $V_{CE} = -5V, I_C = -0.5A$ | - | -0.7 | -1.0 | V |
| Transition Frequency | | f_T | $V_{CE} = -5V, I_C = -0.5A$ | - | 30 | - | MHz |
| Collector Output Capacitance | | C_{ob} | $V_{CB} = -10V, I_E = 0, f = 1MHz$ | - | 45 | - | pF |
| Switching Time | Turn-on Time | t_{on} | | - | 0.4 | - | μs |
| | Storage Time | t_{stg} | | - | 1.7 | - | |
| | Fall Time | t_f | | - | 0.5 | - | |

Note: $h_{FE(1)}$ Classification Y:100~200, GR:150~300.



KTA1040D/L

