

LOW COLLECTOR SATURATION VOLTAGE
LARGE CURRENT

FEATURES

- High Power Dissipation : $P_C=1.3W(T_a=25^\circ C)$
- Complementary to KTA1385D/L

MAXIMUM RATING ($T_a=25^\circ C$)

CHARACTERISTIC		SYMBOL	RATING	UNIT
Collector-Base Voltage		V_{CBO}	60	V
Collector-Emitter Voltage		V_{CEO}	60	V
Emitter-Base Voltage		V_{EBO}	7	V
Collector Current	DC	I_C	5	A
	Pulse *	I_{CP}	8	
Base Current		I_B	1	A
Collector Power Dissipation	$T_a=25^\circ C$	P_C	1.0	W
	$T_c=25^\circ C$		15	
Junction Temperature		T_j	150	$^\circ C$
Storage Temperature Range		T_{stg}	-55 ~ 150	$^\circ C$

* $PW \leq 10ms$, Duty Cycle $\leq 50\%$

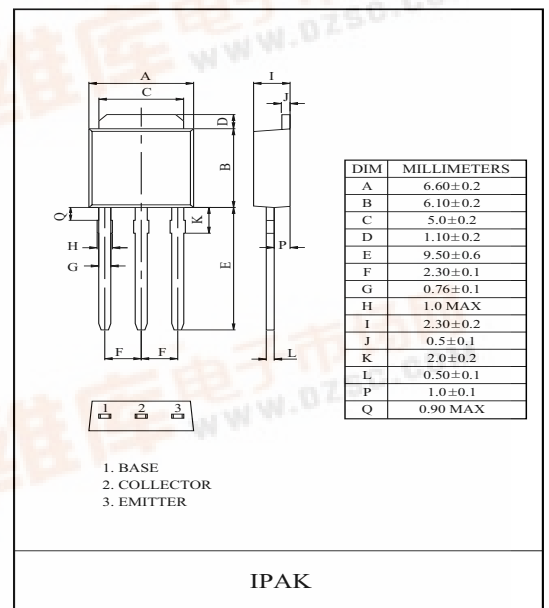
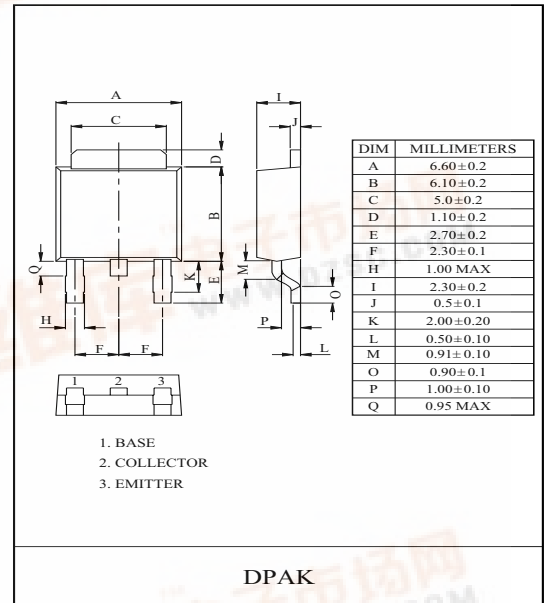

ELECTRICAL CHARACTERISTICS ($T_a=25^\circ C$)

CHARACTERISTIC		SYMBOL	TEST CONDITION	MIN.	TYP.	MAX.	UNIT
Collector Cut-off Current		I_{CBO}	$V_{CB}=50V, I_E=0$	-	-	10	μA
Emitter Cut-off Current		I_{EBO}	$V_{EB}=7V, I_C=0$	-	-	10	μA
DC Current Gain		$h_{FE}(1)$	$V_{CE}=1V, I_C=0.1A$	60	-	-	
		$h_{FE}(2)$ (Note)	$V_{CE}=1V, I_C=2A$	160	-	400	
		$h_{FE}(3)$	$V_{CE}=2V, I_C=5A$	50	-	-	
Collector-Emitter Saturation Voltage *		$V_{CE(sat)}$	$I_C=2A, I_B=0.2A$	-	0.1	0.3	V
Base-Emitter Saturation Voltage *		$V_{BE(sat)}$	$I_C=2A, I_B=0.2A$	-	0.9	1.2	V
Switching Time	Turn On Time	t_{on}	<p>$I_{B1}=-I_{B2}=0.2A$ DUTY CYCLE $\leq 1\%$</p>	-	0.2	1	μS
	Storage Time	t_{stg}		-	1.1	2.5	
	Fall Time	t_f		-	0.2	1	

* Pulse test: $PW \leq 50\mu S$, Duty Cycle $\leq 2\%$ Pulse

Note) $h_{FE}(2)$ Classification : O:160 ~ 320, Y:200 ~ 400.



KTC5103D/L

Pc - Ta

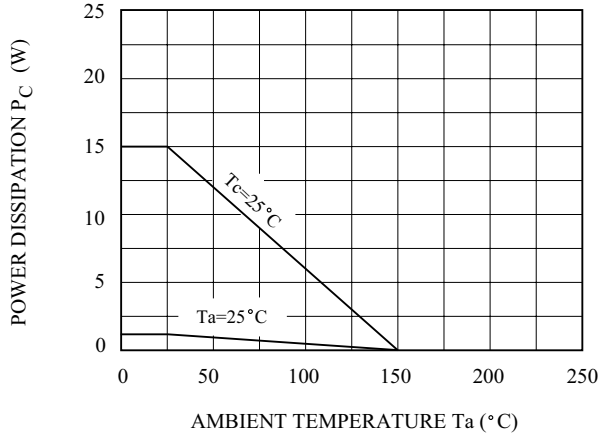

d_T - T_C

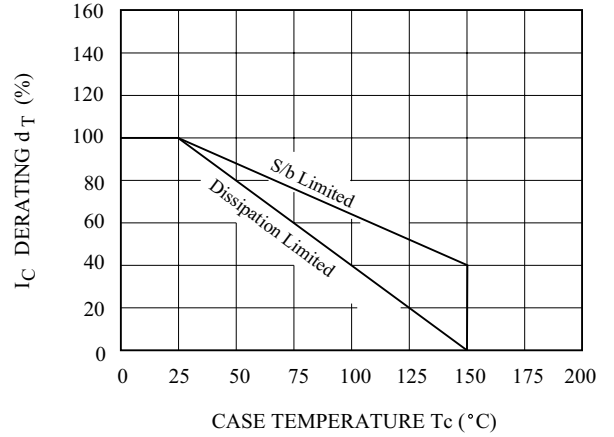

SAFE OPERATING AREA

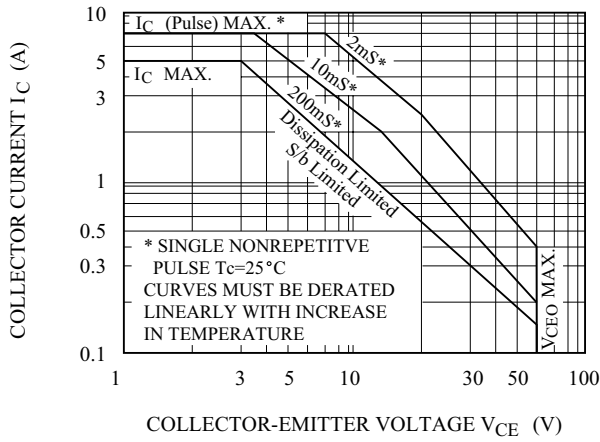

REVERSE BIAS SAFE OPERATING AREA

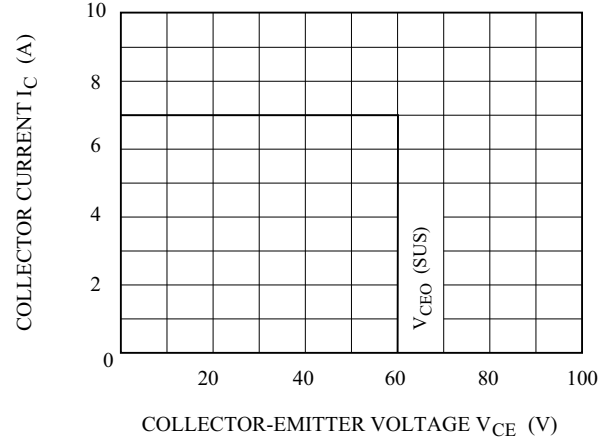

I_C - V_{CE}

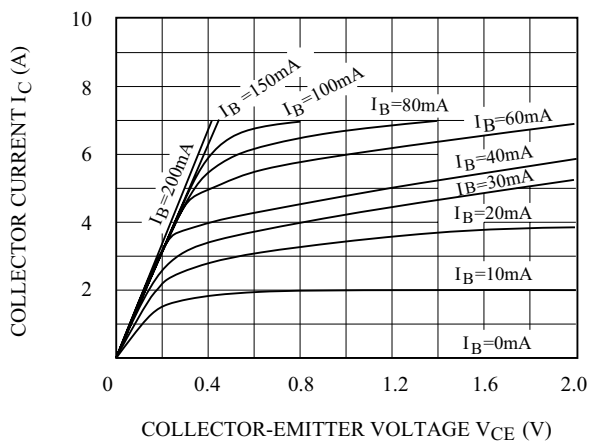

h_{FE} - I_C

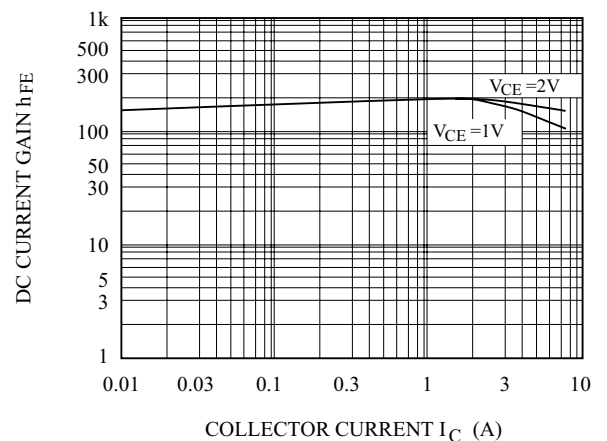

KTC5103D/L

