

T-1 3/4 (5mm) LED LAMP

L-7113SYC-H SUPERBRIGHT YELLOW

Features

- ULTRABRIGHTNESS.
- WATER CLEAR LENS ARE AVAILABLE.
- OUTSTANDING MATERIAL EFFICIENCY.
- RELIABLE AND RUGGED.
- IC COMPATIBLE/LOW CURRENT CAPABILITY.

Description

Super Bright Yellow source color devices are made with DH InGaAlP on GaAs substrate Light Emitting Diode.

Package Dimensions

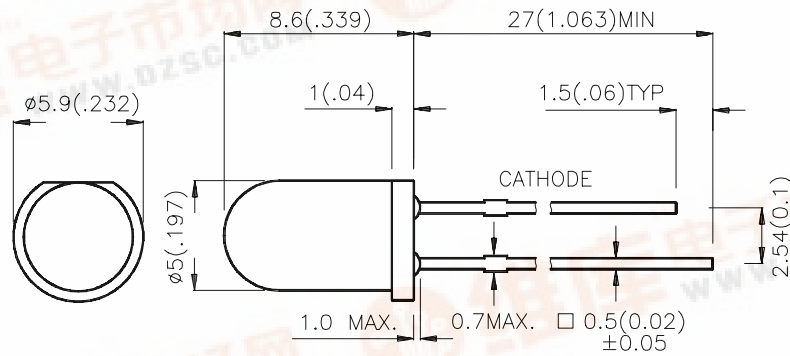

Notes:

1. All dimensions are in millimeters (inches).
2. Tolerance is $\pm 0.25 (0.01)$ unless otherwise noted.
3. Lead spacing is measured where the lead emerge package.
4. Specifications are subject to change without notice.

Kingbright

Selection Guide

Part No.	Dice	Lens Type	Iv (mcd) @ 20 mA		Viewing Angle
			Min.	Typ.	θ1/2
L-7113SYC-H	SUPER BRIGHT YELLOW (InGaAlP)	WATER CLEAR	1500	2100	20°

Note:

1. θ1/2 is the angle from optical centerline where the luminous intensity is 1/2 the optical centerline value.

Electrical / Optical Characteristics at T_A=25°C

Symbol	Parameter	Device	Typ.	Max.	Units	Test Conditions
λ _{peak}	Peak Wavelength	Super Bright Yellow (SY-H)	590		nm	IF=20mA
λ _D	Dominate Wavelength	HSuper Bright Yellow (SY-H)	589		nm	IF=20mA
Δλ _{1/2}	Spectral Line Halfwidth	Super Bright Yellow (SY-H)	20		nm	IF=20mA
C	Capacitance	Super Bright Yellow (SY-H)	45		pF	VR=0V;f=1MHz
V _F	Forward Voltage	Super Bright Yellow (SY-H)	2.3	2.8	V	IF=20mA
I _R	Reverse Current	Super Bright Yellow (SY-H)		10	uA	VR = 5V

Absolute Maximum Ratings at T_A=25°C

Parameter	Super Bright Yellow (SY-H)	Units
Power dissipation	120	mW
DC Forward Current	30	mA
Peak Forward Current [1]	140	mA
Reverse Voltage	5	V
Operating/Storage Temperature	-40°C To +85°C	
Lead Solder Temperature [2]	260°C For 5 Seconds	

Notes:

1. 1/10 Duty Cycle, 0.1ms Pulse Width.
2. 4mm below package base.

Kingbright

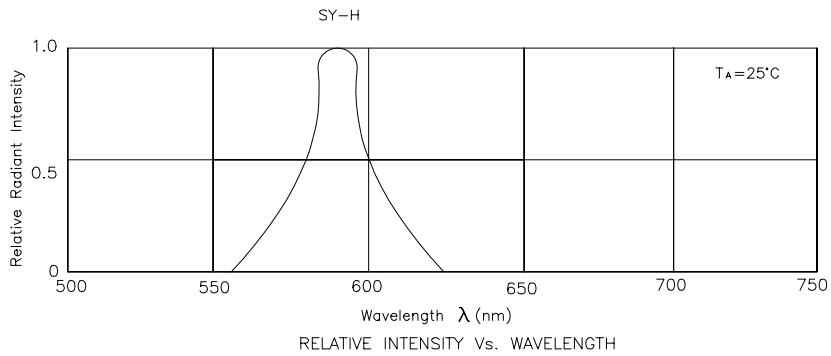

Super Bright Yellow L-7113SYC-H

