

NIKO-SEM

3A Fixed Low Dropout Linear Regulator (LDO)

L1085-3.3
TO-252,263,220

GENERAL DESCRIPTION

The L1085 is a positive and low dropout three-terminal voltage regulator with 3A output current capability. This device is designed for use in low voltage applications that offers lower dropout voltage and faster transient response.

This device is fully protected against over current faults, over temperature operation, reversed input polarity, reversed lead insertion, transient voltage spike ...etc.

On-Chips trimming the reference voltage to 1% and features the low dropout of maximum 1.50 volts.

The L1085 Series regulators are available in the popular industry standard TO-263 TO-220 and TO-252 packages.

FEATURES

- Very easy to use, it requires only two external resistors to set the output voltage
- Low dropout voltage: 1.3V typical at up to 3A
- Low ground current
- Fast transient response
- Current & thermal limiting
- Line regulation: 0.5% typical
- Load regulation: 0.5% typical
- TO-263, TO-220 and TO-252 packages

APPLICATIONS

- High current microprocessor supplies
- Low voltage logic supply
- Powering VGA & sound card
- Portable instrumentation
- Constant current regulator
- Post regulator for switching power supply

TYPICAL APPLICATION

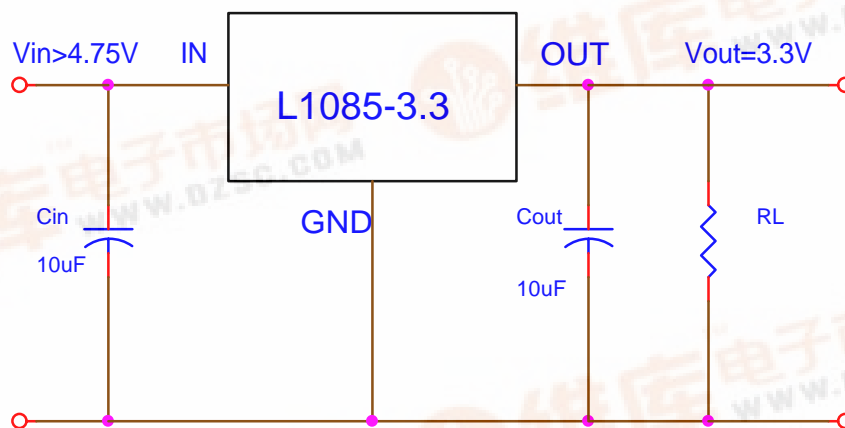

Basic Fixed Output Regulator Circuit

ABSOLUTE MAXIMUM RATINGS

- Maximum Supply Voltage 7V
- Power Dissipation Internally Limited
- Thermal Resistance Junction to Case, θ_{JC} 5 °C/W
- Thermal Resistance Junction to Ambient, θ_{JA}
 - TO-263 60 °C/W
 - TO-252 70 °C/W
 - TO-220 50 °C/W
- Operating Junction Temperature Range 0 to 125 °C
- Storage Temperature Range -40 to 150 °C
- Lead Temperature (Soldering, 10 Seconds) 260 °C

ELECTRICAL CHARACTERISTICS (Unless otherwise specified, $T_A = 25\text{ °C}$.)

Parameter	Symbol	Test Conditions	Typical	Limits
Output Voltage (Fixed Version)	V_o	$V_{IN} = 5V, I_{OUT} = 10mA$	3.3V	$3.234V_{Min}$ $3.367V_{Max}$
Dropout Voltage	V_D	$\Delta V_{REF} = 1\%, I_{OUT} = 3A$	1.3V	1.50V
Line Regulation	$REG_{(LINE)}$	$(V_{OUT} + 1.5V) \leq V_{IN} \leq 7V, I_{OUT} = 10mA$	0.5%	2%
Load Regulation	$REG_{(LOAD)}$	$(V_{IN} - V_{OUT}) = 3V, 10mA \leq I_{OUT} \leq 3A$	0.5%	2.5%
Minimum Load Current	I_o	$1.5V \leq (V_{IN} - V_{OUT}) \leq 5.75V$	10mA	
GND Pin Current	I_{GND}		55 μ A	100 μ A
Current Limit	I_{CL}	$V_{IN} - V_{OUT} = 2V$	5.0A	4.0A (Min)
RMS Output Noise	V_N		0.003% of V_{OUT}	
Ripple Rejection Ratio	R_A	$f = 120Hz, C_{ADJ} = 22\mu F$ for ADJ pin, $V_{IN} = 5V, I_{OUT} = 3A$	72dB	60dB (Min)

DEVICE SELECTION GUIDE

Device	L1085D-3.3	L1085S-3.3	L1085S3-3.3	L1085T-3.3	L1085S5-3.3
Package	TO-252	TO-263 (2-Lead)	TO-263 (3-Lead)	TO-220	TO-263 (5-Lead)
Marking	L1085-33	L1085-33	L1085-33	L1085-33	L1085-33

PIN CONFIGURATIONS

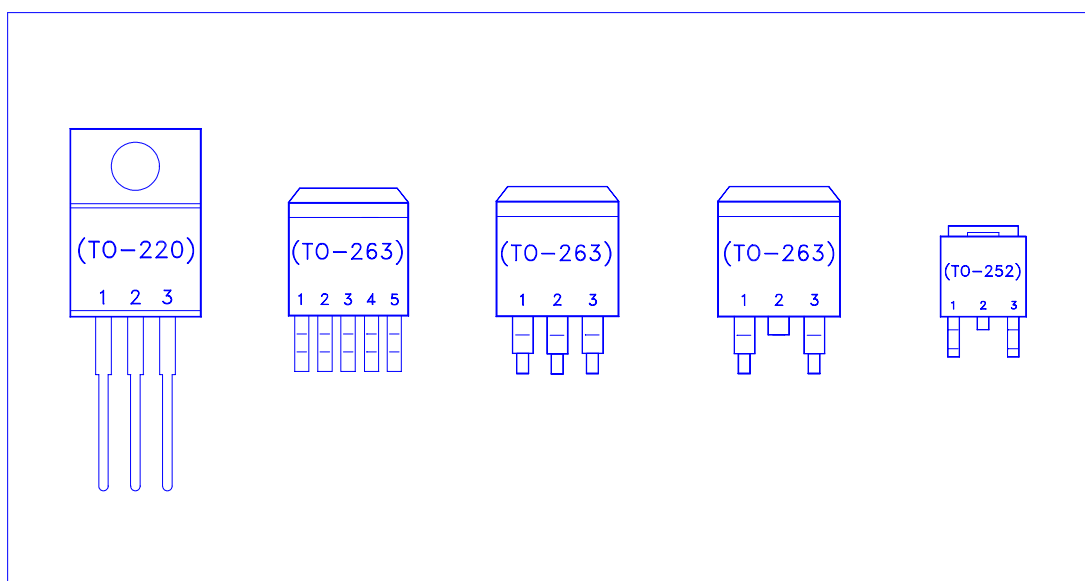

Pin #	Function
1	GND
2	Output
3	Input

Note: TAB is Output Pin

Pin #	Function
2	GND
3	Output
5	Input

Note: TAB is Output Pin (For 5-pin)

TO-263 (D²PAK) MECHANICAL DATA

Dimension	mm			Dimension	mm		
	Min.	Typ.	Max.		Min.	Typ.	Max.
A	14.5	15	15.8	H	1.0	1.5	1.8
B	4.2		4.7	I	9.8		10.3
C	1.20		1.35	J		6.5	
D		2.8		K		1.5	
E	0.3	0.4	0.5	L	0.7		1.4
F	-0.102		0.203	M	4.83	5.08	5.33
G	8.5	9	9.5	N			

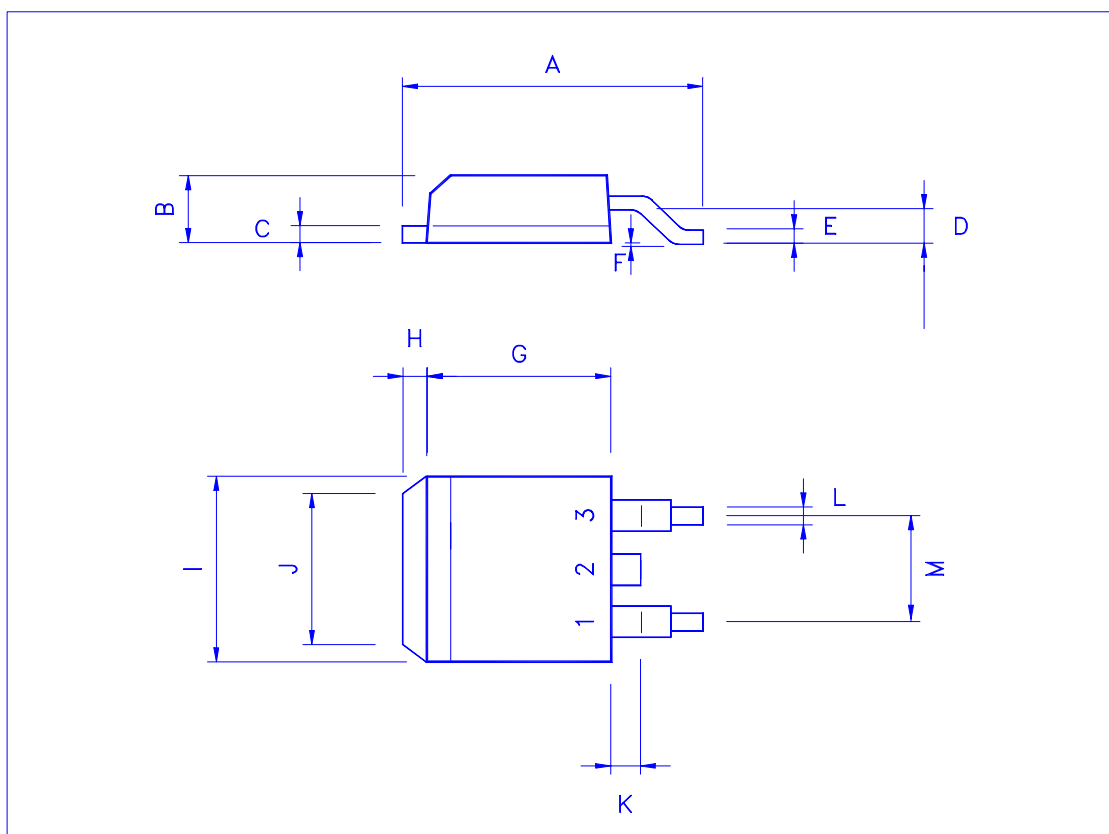

TO-263 (D²PAK) MECHANICAL DATA

Dimension	mm			Dimension	mm		
	Min.	Typ.	Max.		Min.	Typ.	Max.
A	14.5	15	15.8	H	1.0	1.5	1.8
B	4.2		4.7	I	9.8		10.3
C	1.20		1.35	J		6.5	
D		2.8		K		1.5	
E	0.3	0.4	0.5	L	0.7		1.4
F	-0.102		0.203	M	4.83	5.08	5.33
G	8.5	9	9.5	N			

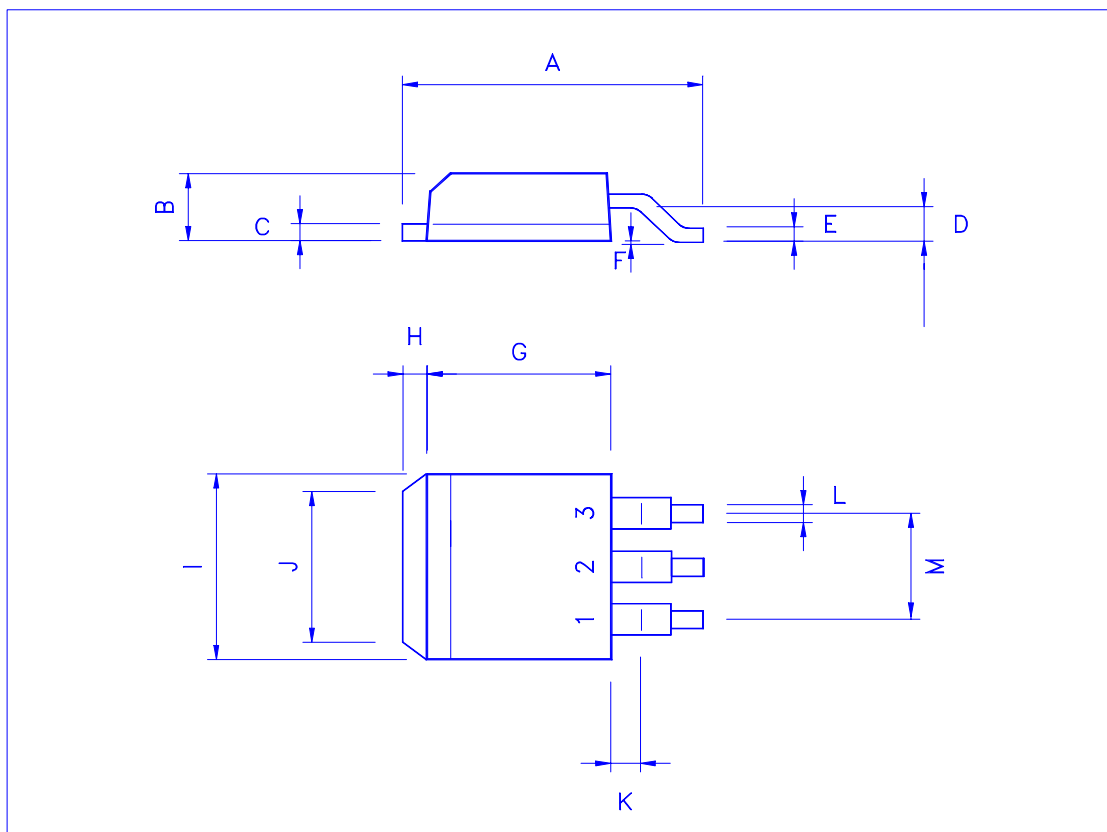

TO-220 (3-Lead) MECHANICAL DATA

Dimension	mm			Dimension	mm		
	Min.	Typ.	Max.		Min.	Typ.	Max.
A	9.78	10.16	10.54	H	2.4	2.54	2.68
B	2.61	2.74	2.87	I	1.19	1.27	1.35
C		20		J	4.4	4.6	4.8
D	28.5	28.9	29.3	K	1.14	1.27	1.4
E	14.6	15.0	15.4	L	2.3	2.6	2.9
F	8.4	8.8	9.2	M	0.26	0.46	0.66
G	0.72	0.8	0.88	N		7°	

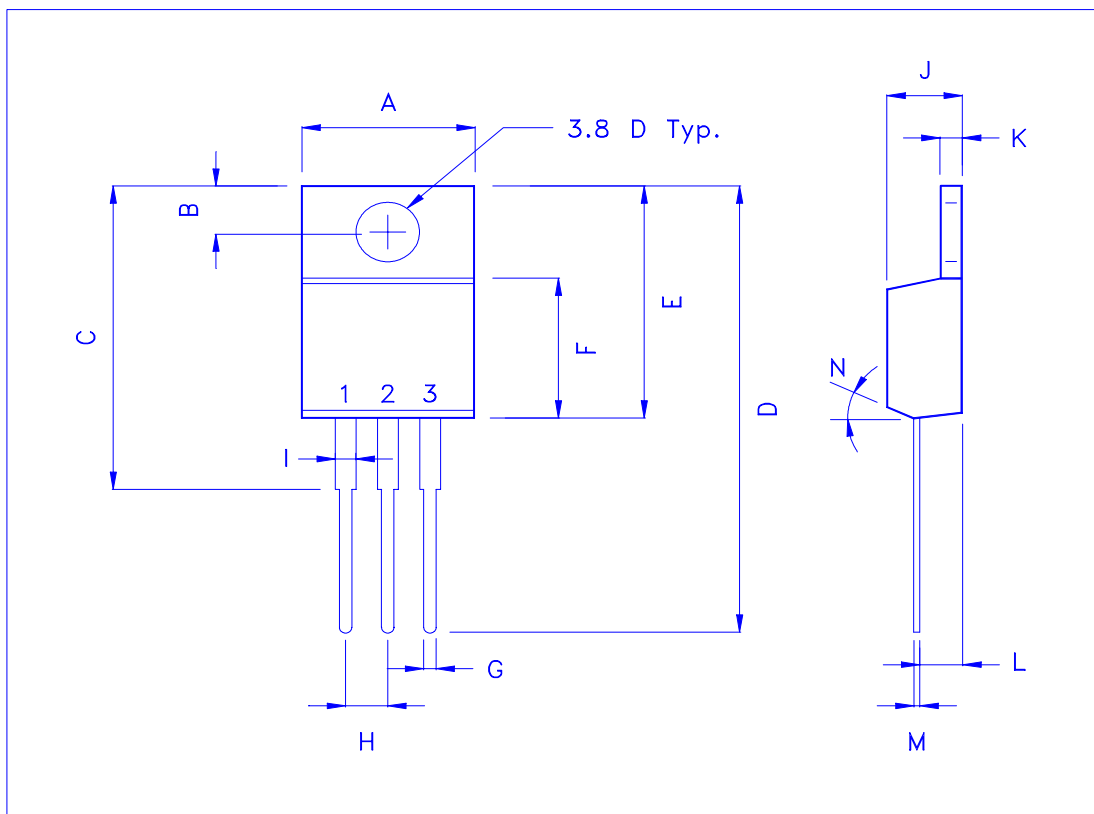

TO-263 (D²PAK, 5-Lead) MECHANICAL DATA

Dimension	mm			Dimension	mm		
	Min.	Typ.	Max.		Min.	Typ.	Max.
A	14.5	15	15.8	H	1.0	1.5	1.8
B	4.2		4.7	I	9.8		10.3
C	1.20		1.35	J		6.5	
D		2.8		K		1.5	
E	0.3	0.4	0.5	L	0.7	0.85	1.0
F	-0.102		0.203	M	1.57	1.7	1.83
G	8.5	9	9.5	N			

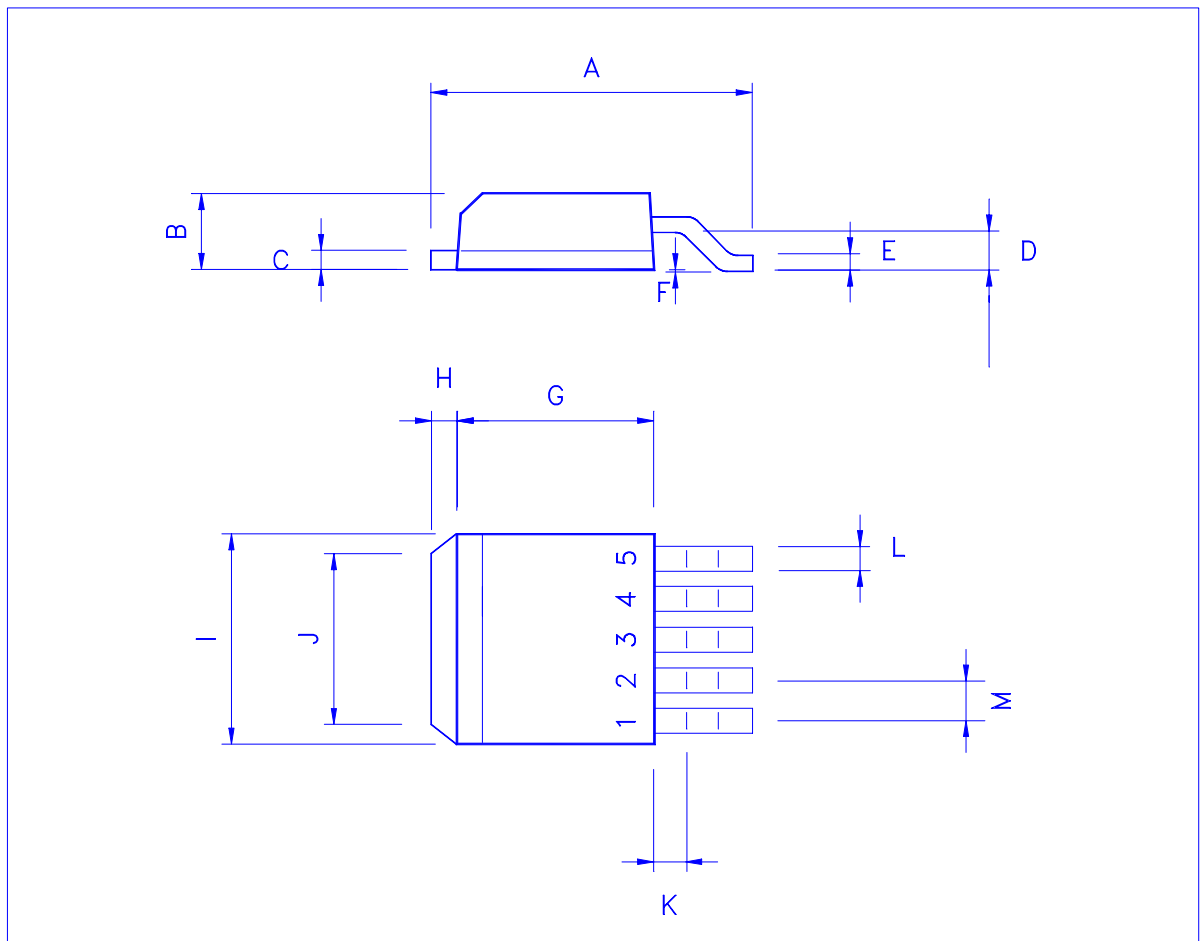

TO-252 (DPAK) MECHANICAL DATA

Dimension	mm			Dimension	mm		
	Min.	Typ.	Max.		Min.	Typ.	Max.
A	9.35		10.1	H		0.8	
B	2.2		2.4	I	6.4		6.6
C	0.48		0.6	J	5.2		5.4
D	0.89		1.5	K	0.6		1
E	0.45		0.6	L	0.64		0.9
F	0.03		0.23	M	4.4		4.6
G	6		6.2	N			

