

# UTC L2949E LINEAR INTEGRATED CIRCUIT

## MULTIFUNCTION VERY LOW DROP VOLTAGE REGULATOR

### DESCRIPTION

The UTC L2949E is a monolithic integrated 5V voltage regulator with a very low dropout output and additional functions as power-on reset and input voltage sense. It is designed for supplying the microcomputer controlled systems especially in automotive applications.

### FEATURES

- \*Operating dc supply voltage range 5V to 28V.
- \*Transient supply voltage up to 40V.
- \*Extremely low quiescent current in standby mode.
- \*High precision standby output voltage  $5V \pm 1\%$
- \*Output current capability up to 100mA.
- \*Very low dropout voltage less than 0.5V.
- \*Reset circuit sensing the output voltage
- \*Programmable reset pulse delay with external capacitor
- \*Voltage sense comparator.
- \*Thermal shutdown and short circuit protections.

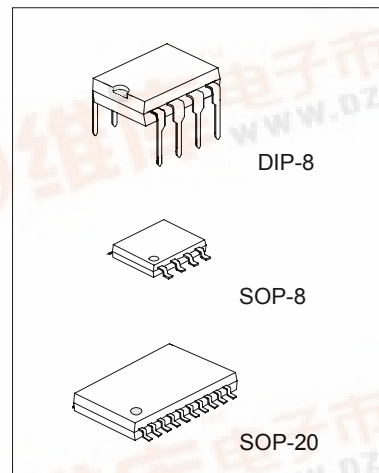

### PIN CONNECTIONS

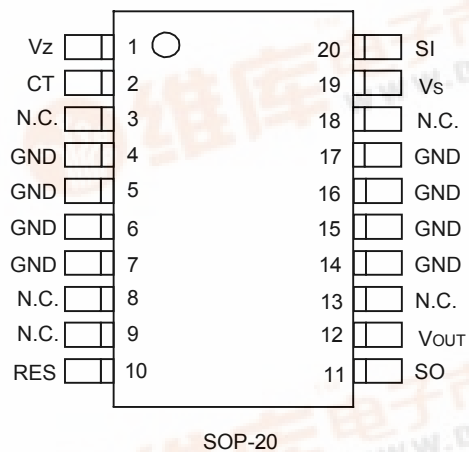
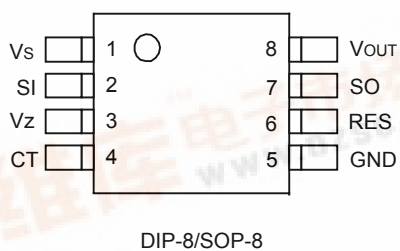

# UTCL2949E LINEAR INTEGRATED CIRCUIT

## BLOCK DIAGRAM

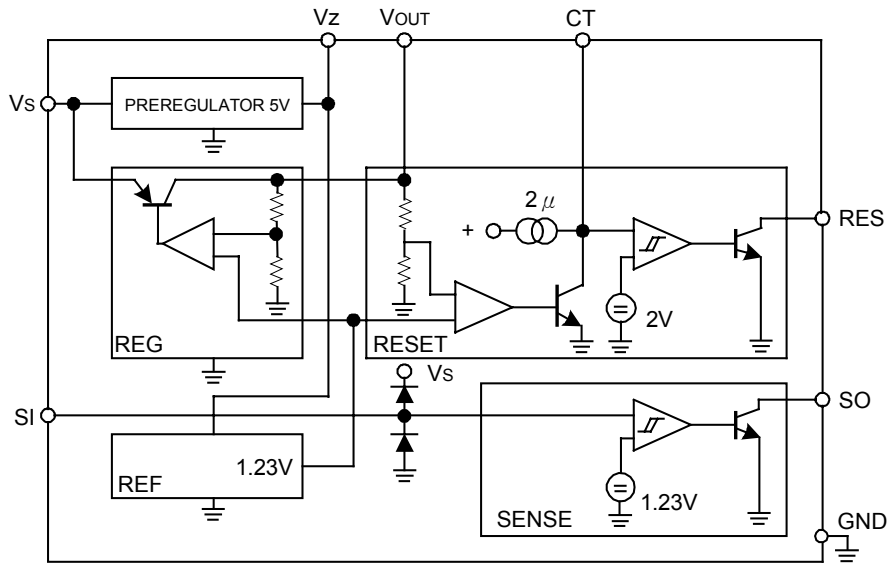

## ABSOLUTE MAXIMUM RATINGS

PARAMETER	SYMBOL	RATING	UNIT
DC Operating Supply Voltage	$V_{CC}$	28	V
Transient Supply Voltage( $T < 1s$ )	$V_{CC TR}$	40	V
Output Current	$I_o$	Internally Limited	
Output Voltage	$V_o$	20	V
Output Voltage Reset Output	$V_{RES}$	20	V
Sense Output	$V_{SO}$	20	V
Output Current Reset Output	$I_{RES}$	5	mA
Sense Output	$I_{SO}$	5	mA
Preregulator Output Voltage	$V_z$	7	V
Preregulator Output Current	$I_z$	5	mA
Junction Temperature	$T_j$	-40~+150	°C
Storage Temperature Range	$T_{stg}$	-55~+150	°C

# UTCL2949E LINEAR INTEGRATED CIRCUIT

## THERMAL DATA

DESCRIPTION	SYMBOL	RATING	UNIT
Thermal Resistance Junction-ambient DIP-8 SOP-8 SOP-20	Rth j-amb	100 200 50	°C/W
Thermal Resistance Junction-pin (SOP-20)	Rth j-pins	15	°C/W
Thermal Shutdown Junction temperature	TJSD	165	°C

## ELECTRICAL CHARACTERISTICS (Vs=14V; -40°C < Tj < 125°C unless otherwise specified)

PARAMETER	SYMBOL	CONDITIONS	MIN	TYP.	MAX	UNIT
Output Voltage	Vo	Tj=25°C; Io=1mA	4.95	5	5.05	V
Output Voltage	Vo	6V < VIN < 28V, 1mA < Io < 50mA	4.90	5	5.10	V
Output Voltage	Vo	VIN=40V; T < 1s 5mA < Io < 100mA	4.75		5.25	V
Dropout voltage	VD	Io=10mA		0.1	0.25	V
		Io=50mA		0.2	0.4	V
		Io=100mA		0.3	0.5	V
Input to Output Voltage Difference in Undervoltage Condition	Vio	VIN=4V, Io=35mA			0.4	V
Max Output Leakage	IOUTH **	VIN=25V, Vo=5.5V	20	50	80	μA
Line Regulation	Vol	6V < VIN < 28V, Io=1mA			20	mV
Load Regulation	VolO	1mA < Io < 100mA			30	mV
Current Limit	ILIM	Vo=4.5V	105	200	400	mA
		Vo=4.5V, Tj=25°C	120		400	mA
		Vo=0V (note 1)		100		
Quiescent Current	IqSE	Io=0.3mA; Tj < 100°C		200	300	μA
Quiescent Current	Iq	Io=100mA			5	mV

\*\* With this test we guarantee that with no output current the output voltage will not exceed 5.5V

## RESET

PARAMETER	SYMBOL	CONDITIONS	MIN	TYP.	MAX	UNIT
Reset Threshold Voltage	VRT			Vo-0.5V		V
Reset Threshold Hysteresis	VRTH		50	100	200	mV
Reset Pulse Delay	trD	CT=100nF; TR ≥ 100 μs	55	100	180	ms
Reset Output Low Voltage	VRL	RRES=10K Ω to Vs ≥ 1.5V			0.4	V
Reset Output High Leakage Current	IRH	VRES=5V			1	μA
Delay Comparator Threshold	VCTH			2		V
Delay Comparator Threshold Hysteresis	VCTH,hy			100		mV

# UTCL2949E LINEAR INTEGRATED CIRCUIT

## SENSE

PARAMETER	SYMBOL	CONDITIONS	MIN	TYP.	MAX	UNIT
Sense Low Threshold	Vst		1.16	1.23	1.35	V
Sense Threshold Hysteresis	Vsth		20	100	200	mV
Sense Output Low Voltage	VSL	$V_{SI} \cong 1.16V; V_S \cong 3V$ $R_{SO}=10K\Omega$ to $V_O$			0.4	V
Sense Output Leakage	I <sub>SH</sub>	$V_{SO}=5V; V_{SI} \cong 1.5V$			1	$\mu A$
Sense Input Current	I <sub>SI</sub>	$V_{SI}=0$	-20	-8	-3	$\mu A$

## PREREGULATOR

PARAMETER	SYMBOL	CONDITIONS	MIN	TYP.	MAX	UNIT
Preregulator Output Voltage	Vz	$I_z=10\mu A$	4.5	5	6	V
Preregulator Output Current	Iz				10	$\mu A$

Note 1: Foldback characteristic

## APPLICATION CIRCUIT

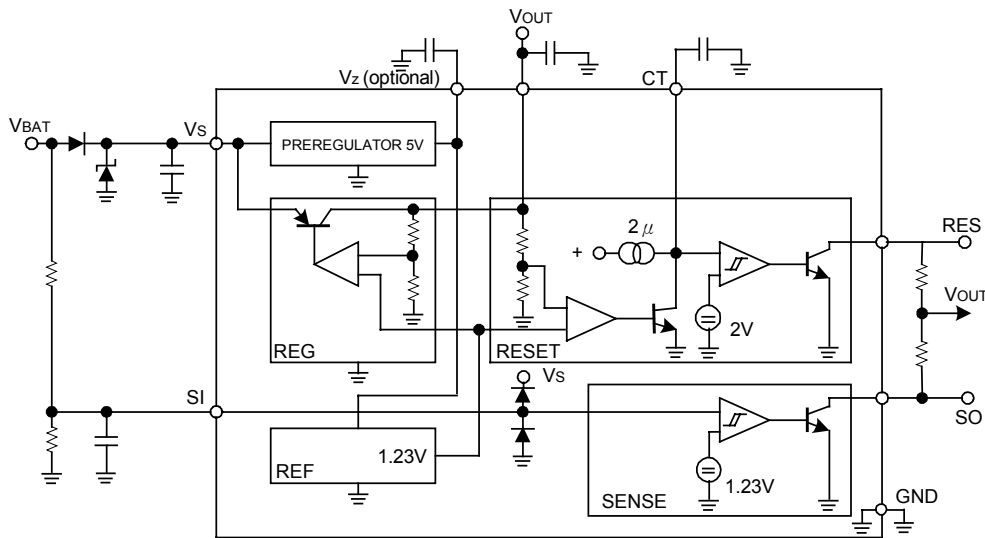

For stability:  $C_s \cong 1\mu F$ ,  $C_o \cong 4.7\mu F$ ,  $ESR < 10\Omega$  at 10KHz

Recommended for application:  $C_s=C_o=10\mu F$  to  $100\mu F$

## APPLICATION INFORMATION

### Suppl Voltage Transient

High supply voltage transients can cause a reset output signal disturbance.

For supply voltage greater than 8V the circuit shows a high immunity of the reset output against supply transients of the reset output against supply transients of more than  $100V/\mu s$ .

For supply voltages less than 8V supply transients of more than  $0.4V/\mu s$  can cause a reset signal disturbance.

To improve the transient behaviour for supply voltages less than 8V a capacitor at pin 3 can be used.

A capacitor at pin 3 ( $C_3 \cong 1\mu F$ ) reduces also the output noise.

# UTCL2949E LINEAR INTEGRATED CIRCUIT

## FUNCTIONAL DESCRIPTION

The UTC L2949E is a monolithic integrated voltage regulator, based on the STM modular voltage regulator approach. Several outstanding features and auxiliary functions are implemented to meet the requirements of supplying microprocessor systems in automotive applications. Nevertheless, it is suitable also in other applications where the present functions are required. The modular approach of this device allows to get easily also other features and functions when required.

### Voltage Regulator

The voltage regulator uses an Isolated Collector Vertical PNP transistor as a regulating element.

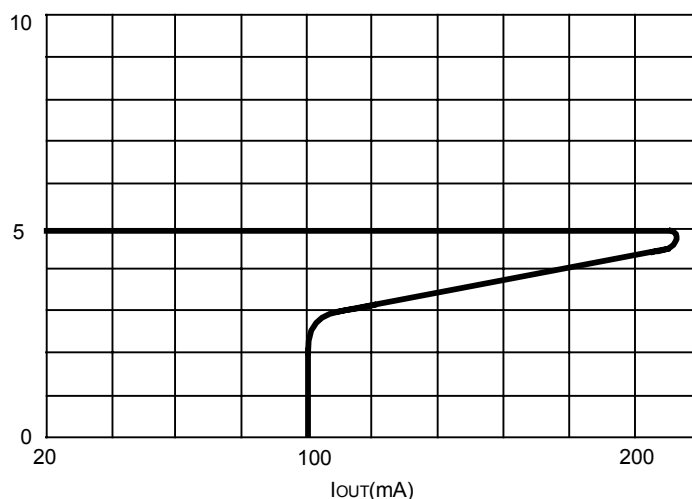

Figure 1: Foldback Characteristic of  $V_o$

With this structure very low dropout voltage at currents up to 100mA is obtained. The dropout operation of the standby regulator is maintained down to 3V input supply voltage. The output voltage is regulated up to the transient input supply voltage of 4V. With this feature no functional interruption due to overvoltage pulses is generated. The typical curve showing the standby output voltage as a function of the input supply voltage is shown in Fig. 2. The current consumption of the device (quiescent current) is less than 300  $\mu$  A.

To reduce the quiescent current peak in the undervoltage region and to improve the transient response in this region, the dropout voltage is controlled, the quiescent current as a function of the supply input voltage is shown in Fig. 3.

# UTCL2949E LINEAR INTEGRATED CIRCUIT

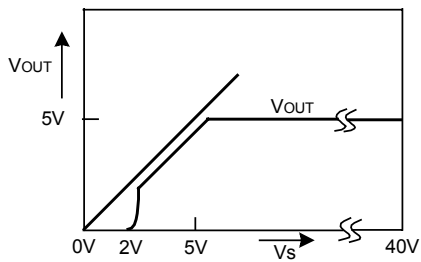

Figure 2: Output Voltage vs. Input voltage

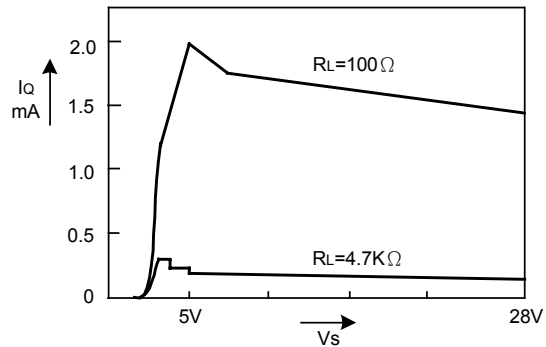

Figure 3: Quiescent Current vs. Supply Voltage

## Preregulator

To improve the transient immunity a preregulator stabilized the internal supply voltage to 5V. This internal voltage is present at Pin3 (Vz). This voltage should not be used as an output because the output capability is very small ( $\cong 10 \mu A$ ).

This output may be used as an option when a better transient behaviour for supply voltages less than 8V is required (see also application note).

In this case a capacitor (100nF - 1  $\mu F$ ) must be connected between Pin3 and GND. If this feature is not used Pin3 must be left open.

## Reset Circuit

The block circuit diagram of the reset circuit is shown in Fig.4. the reset circuit supervises the output voltage.

The reset threshold of 4.5V is defined with the internal reference voltage and standby output divider.

The reset pulse delay time  $TRD_i$  is defined with the charge time of an external capacitor  $C_T$ :

$$TRD = \frac{C_T \bullet 2V}{2 \mu A}$$

The reaction time of the reset circuit originates from the discharge time limitation of the reset capacitor  $C_T$  and is proportional of the reset capacitor  $C_T$  and is proportional to the value of  $C_T$ .

The reaction time of the reset circuit increases the noise immunity. Standby output voltage drops below the reset threshold only a bit longer than the reaction time results in a shorter reset delay time.

The nominal reset delay time will be generated for standby output voltage drops longer than approximately 50  $\mu s$ .

The typical reset output waveforms are shown in Fig.5.

## Sense Comparator

The sense comparator compares an input signal with an internal voltage reference of typical 1.23V. The use of an external voltage divider makes this comparator flexible in the application.

It can be used to supervise the input voltage either before or after the protection diode and to give additional informations to the microprocessor like low voltage warnings.

# UTCL2949E LINEAR INTEGRATED CIRCUIT

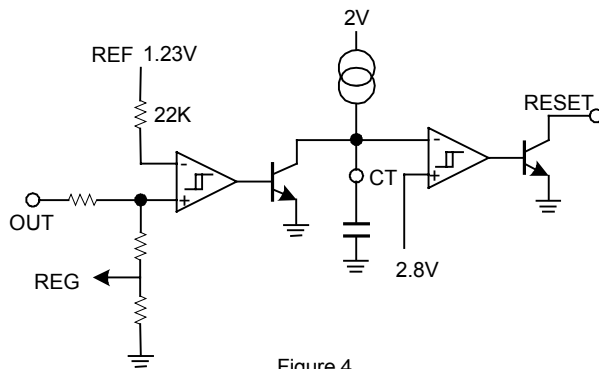

Figure 4

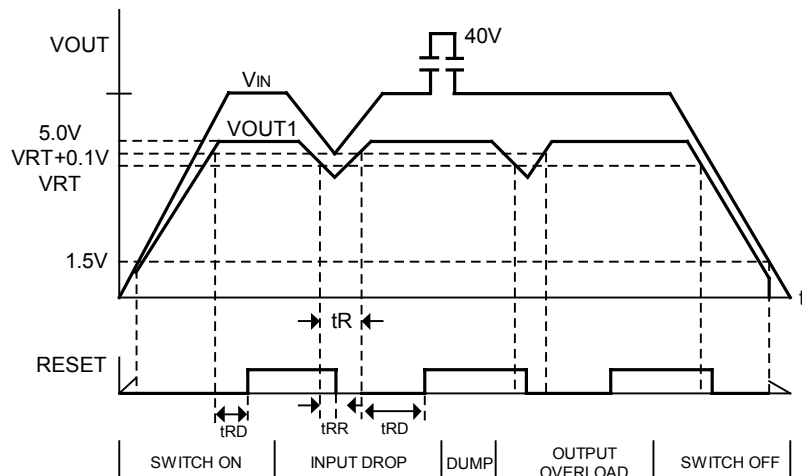

Figure 5

UTC assumes no responsibility for equipment failures that result from using products at values that exceed, even momentarily, rated values (such as maximum ratings, operating condition ranges, or other parameters) listed in products specifications of any and all UTC products described or contained herein. UTC products are not designed for use in life support appliances, devices or systems where malfunction of these products can be reasonably expected to result in personal injury. Reproduction in whole or in part is prohibited without the prior written consent of the copyright owner. The information presented in this document does not form part of any quotation or contract, is believed to be accurate and reliable and may be changed without notice.