



L29C520/521

4 x 8-bit Multilevel Pipeline Register

FEATURES

- ❑ Four 8-bit Registers
- ❑ Implements Double 2-Stage Pipeline or Single 4-Stage Pipeline Register
- ❑ Hold, Shift, and Load Instructions
- ❑ Separate Data In and Data Out Pins
- ❑ High-Speed, Low Power CMOS Technology
- ❑ Three-State Outputs
- ❑ Replaces IDT29FCT520/IDT29FCT521 and AMD Am29520/Am29521
- ❑ Package Styles Available:
 - 24-pin PDIP
 - 28-pin PLCC, J-Lead

DESCRIPTION

The L29C520 and L29C521 are pin-for-pin compatible with the IDT29FCT520/IDT29FCT521 and AMD Am29520/Am29521, implemented in low power CMOS.

The L29C520 and L29C521 contain four registers which can be configured as two independent, 2-level pipelines or as one 4-level pipeline.

The Instruction pins, I1-0, control the loading of the registers. For either device, the registers may be configured as a four-stage delay line, with data loaded into R1 and shifted sequentially through R2, R3, and R4. Also, for the L29C520, data may be loaded from the inputs into either R1 or R3 with only R2 or R4 shifting. The L29C521 differs from the L29C520 in that R2 and R4 remain unchanged during this type of data load, as shown in Tables 1 and 2. Finally, I1-0 may be set to prevent any register from changing.

The S1-0 select lines control a 4-to-1 multiplexer which routes the contents of any of the registers to the Y output pins. The independence of the I and S controls allows simultaneous write and read operations on different registers.

TABLE 1.
L29C520 INSTRUCTION TABLE

I1	I0	Description
L	L	D→R1 R1→R2 R2→R3 R3→R4
L	H	HOLD HOLD D→R3 R3→R4
H	L	D→R1 R1→R2 HOLD HOLD
H	H	ALL REGISTERS ON HOLD

TABLE 2.
L29C521 INSTRUCTION TABLE

I1	I0	Description
L	L	D→R1 R1→R2 R2→R3 R3→R4
L	H	HOLD HOLD D→R3 HOLD
H	L	D→R1 HOLD HOLD HOLD
H	H	ALL REGISTERS ON HOLD

TABLE 3. OUTPUT SELECT

S1	S0	Register Selected
L	L	Register 4
L	H	Register 3
H	L	Register 2
H	H	Register 1

L29C520/521 BLOCK DIAGRAM

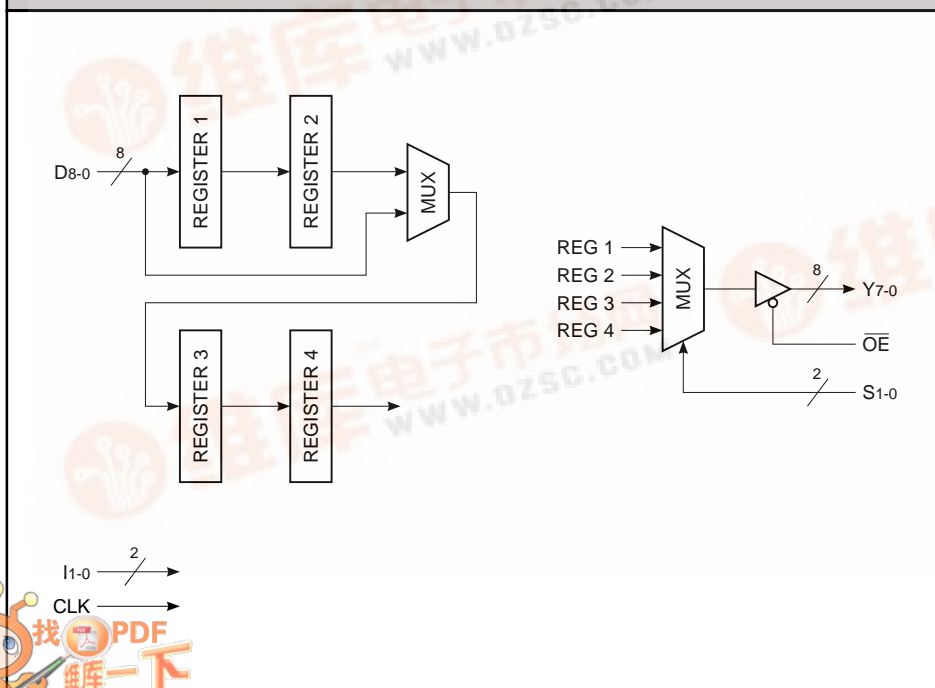

4 x 8-bit Multilevel Pipeline Register
MAXIMUM RATINGS *Above which useful life may be impaired (Notes 1, 2, 3, 8)*

Storage temperature	–65°C to +150°C
Operating ambient temperature	–55°C to +125°C
V _{CC} supply voltage with respect to ground	–0.5 V to +7.0 V
Input signal with respect to ground	–3.0 V to +7.0 V
Signal applied to high impedance output	–3.0 V to +7.0 V
Output current into low outputs	25 mA
Latchup current	> 400 mA

OPERATING CONDITIONS *To meet specified electrical and switching characteristics*

Mode	Temperature Range (Ambient)	Supply Voltage
Active Operation, Commercial	0°C to +70°C	4.75 V ≤ V _{CC} ≤ 5.25 V
Active Operation, Military	–55°C to +125°C	4.50 V ≤ V _{CC} ≤ 5.50 V

ELECTRICAL CHARACTERISTICS *Over Operating Conditions (Note 4)*

Symbol	Parameter	Test Condition	Min	Typ	Max	Unit
V _{OH}	Output High Voltage	V _{CC} = Min., I _{OH} = –15.0 mA	2.4			V
V _{OL}	Output Low Voltage	V _{CC} = Min., I _{OL} = 24.0 mA			0.5	V
V _{IH}	Input High Voltage		2.0		V _{CC}	V
V _{IL}	Input Low Voltage	(Note 3)	0.0		0.8	V
I _{Ix}	Input Current	Ground ≤ V _{IN} ≤ V _{CC} (Note 12)			±20	μA
I _{OZ}	Output Leakage Current	Ground ≤ V _{OUT} ≤ V _{CC} (Note 12)			±20	μA
I _{CC1}	V _{CC} Current, Dynamic	(Notes 5, 6)			30	mA
I _{CC2}	V _{CC} Current, Quiescent	(Note 7)			1.5	mA

SWITCHING CHARACTERISTICS
COMMERCIAL OPERATING RANGE (0°C to +70°C) Notes 9, 10 (ns)

Symbol		Parameter		L29C520/521-			
				22		14*	
				Min	Max	Min	Max
t _{PD}	Clock to Output Delay		22		14		
t _{SEL}	Select to Output Delay		20		13		
t _{PW}	Clock Pulse Width	10		7			
t _{SI}	Instruction Setup Time	10		5			
t _{HI}	Instruction Hold Time	3		1			
t _{SD}	Data Setup Time	10		5			
t _{HD}	Data Hold Time	3		1			
t _{ENA}	Three-State Output Enable Delay (Note 11)		21		15		
t _{DIS}	Three-State Output Disable Delay (Note 11)		15		12		

MILITARY OPERATING RANGE (-55°C to +125°C) Notes 9, 10 (ns)

Symbol		Parameter		L29C520/521-					
				30*		24*		16*	
				Min	Max	Min	Max	Min	Max
t _{PD}	Clock to Output Delay		30		24		16		
t _{SEL}	Select to Output Delay		30		22		15		
t _{PW}	Clock Pulse Width	15		10		8			
t _{SI}	Instruction Setup Time	15		10		6			
t _{HI}	Instruction Hold Time	5		3		2			
t _{SD}	Data Setup Time	15		10		6			
t _{HD}	Data Hold Time	5		3		2			
t _{ENA}	Three-State Output Enable Delay (Note 11)		25		22		16		
t _{DIS}	Three-State Output Disable Delay (Note 11)		20		16		13		

*DISCONTINUED SPEED GRADE

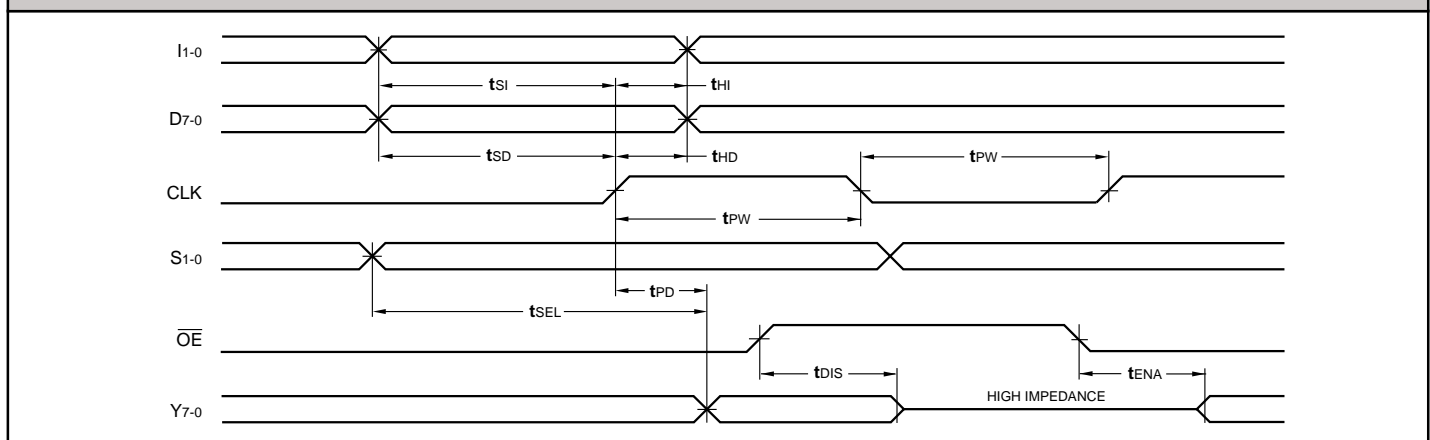
SWITCHING WAVEFORMS

NOTES

1. Maximum Ratings indicate stress specifications only. Functional operation of these products at values beyond those indicated in the Operating Conditions table is not implied. Exposure to maximum rating conditions for extended periods may affect reliability.

2. The products described by this specification include internal circuitry designed to protect the chip from damaging substrate injection currents and accumulations of static charge. Nevertheless, conventional precautions should be observed during storage, handling, and use of these circuits in order to avoid exposure to excessive electrical stress values.

3. This device provides hard clamping of transient undershoot and overshoot. Input levels below ground or above VCC will be clamped beginning at -0.6 V and VCC + 0.6 V. The device can withstand indefinite operation with inputs in the range of -0.5 V to +7.0 V. Device operation will not be adversely affected, however, input current levels will be well in excess of 100 mA.

4. Actual test conditions may vary from those designated but operation is guaranteed as specified.

5. Supply current for a given application can be accurately approximated by:

$$\frac{NCV^2F}{4}$$

where

- N = total number of device outputs
- C = capacitive load per output
- V = supply voltage
- F = clock frequency

6. Tested with all outputs changing every cycle and no load, at a 5 MHz clock rate.

7. Tested with all inputs within 0.1 V of VCC or Ground, no load.

8. These parameters are guaranteed but not 100% tested.

9. AC specifications are tested with input transition times less than 3 ns, output reference levels of 1.5 V (except tDIS test), and input levels of nominally 0 to 3.0 V. Output loading may be a resistive divider which provides for specified IOH and IOL at an output voltage of VOH min and VOL max respectively. Alternatively, a diode bridge with upper and lower current sources of IOH and IOL respectively, and a balancing voltage of 1.5 V may be used. Parasitic capacitance is 30 pF minimum, and may be distributed.

This device has high-speed outputs capable of large instantaneous current pulses and fast turn-on/turn-off times. As a result, care must be exercised in the testing of this device. The following measures are recommended:

a. A 0.1 μF ceramic capacitor should be installed between VCC and Ground leads as close to the Device Under Test (DUT) as possible. Similar capacitors should be installed between device VCC and the tester common, and device ground and tester common.

b. Ground and VCC supply planes must be brought directly to the DUT socket or contactor fingers.

c. Input voltages should be adjusted to compensate for inductive ground and VCC noise to maintain required DUT input levels relative to the DUT ground pin.

10. Each parameter is shown as a minimum or maximum value. Input requirements are specified from the point of view of the external system driving the chip. Setup time, for example, is specified as a minimum since the external system must supply at least that much time to meet the worst-case requirements of all parts. Responses from the internal circuitry are specified from the point of view of the device. Output delay, for example, is specified as a maximum since worst-case operation of any device always provides data within that time.

11. For the tENA test, the transition is measured to the 1.5 V crossing point with datasheet loads. For the tDIS test, the transition is measured to the ±200mV level from the measured steady-state output voltage with ±10mA loads. The balancing voltage, VTH, is set at 3.5 V for Z-to-0 and 0-to-Z tests, and set at 0 V for Z-to-1 and 1-to-Z tests.

12. These parameters are only tested at the high temperature extreme, which is the worst case for leakage current.

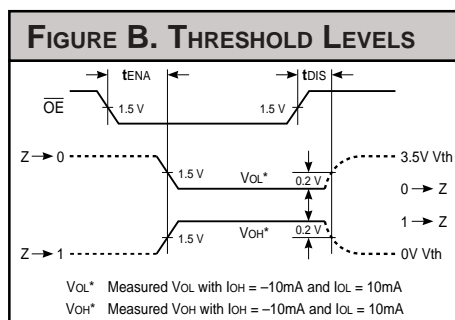
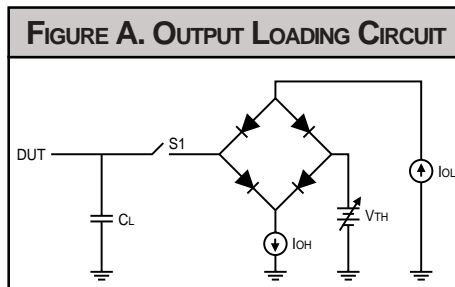

4 x 8-bit Multilevel Pipeline Register

L29C520 — ORDERING INFORMATION

24-pin — 0.3" wide

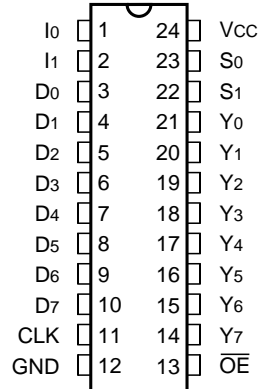

28-pin

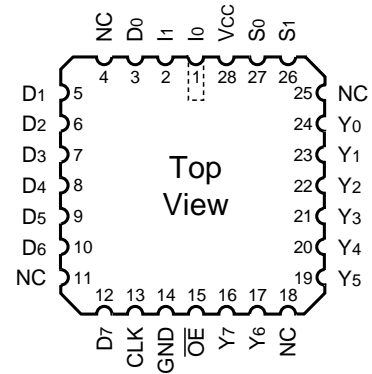

Speed	Plastic DIP (P2)	Plastic J-Lead Chip Carrier (J4)
0°C to +70°C — COMMERCIAL SCREENING		
22 ns	L29C520PC22	L29C520JC22
-55°C to +125°C — COMMERCIAL SCREENING		
-55°C to +125°C — MIL-STD-883 COMPLIANT		

L29C520 — ORDERING INFORMATION

24-pin

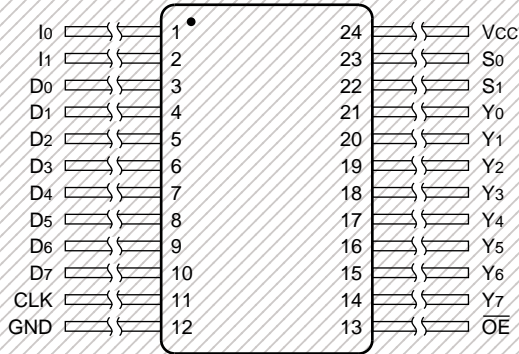

Discontinued Package

24-pin — 0.209" wide

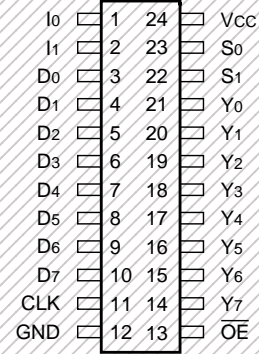

Discontinued Package

Speed	Ceramic Flatpack (M1)	Plastic SSOP (S1)
	0°C to +70°C — COMMERCIAL SCREENING	
22 ns		
	-55°C to +125°C — COMMERCIAL SCREENING	
	-55°C to +125°C — MIL-STD-883 COMPLIANT	

L29C521 — ORDERING INFORMATION

24-pin — 0.3" wide

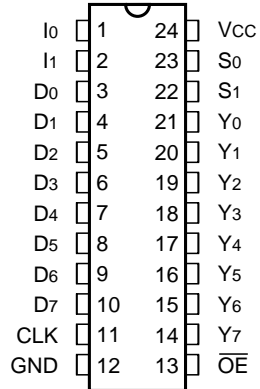

28-pin

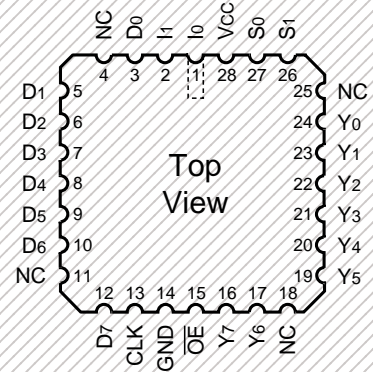

Discontinued Package

Speed	Plastic DIP (P2)	Plastic J-Lead Chip Carrier (J4)
	0°C to +70°C — COMMERCIAL SCREENING	
22 ns	L29C521PC22	
	-55°C to +125°C — COMMERCIAL SCREENING	
	-55°C to +125°C — MIL-STD-883 COMPLIANT	

L29C521 — ORDERING INFORMATION

24-pin

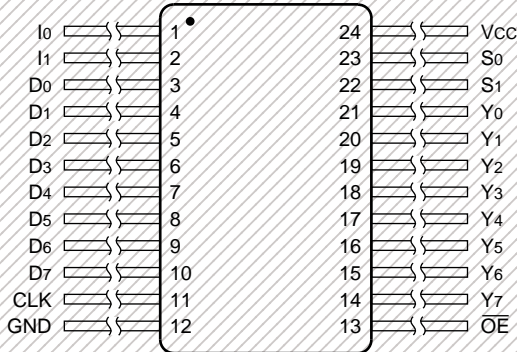

Discontinued Package

Speed	Ceramic Flatpack (M1)	
	0°C to +70°C — COMMERCIAL SCREENING	
	-55°C to +125°C — COMMERCIAL SCREENING	
	-55°C to +125°C — MIL-STD-883 COMPLIANT	