

**FAIRCHILD**  
SEMICONDUCTOR®

# 6-PIN DIP OPTOISOLATORS LOGIC OUTPUT

H11L1M

H11L2M

H11L3M

## PACKAGE

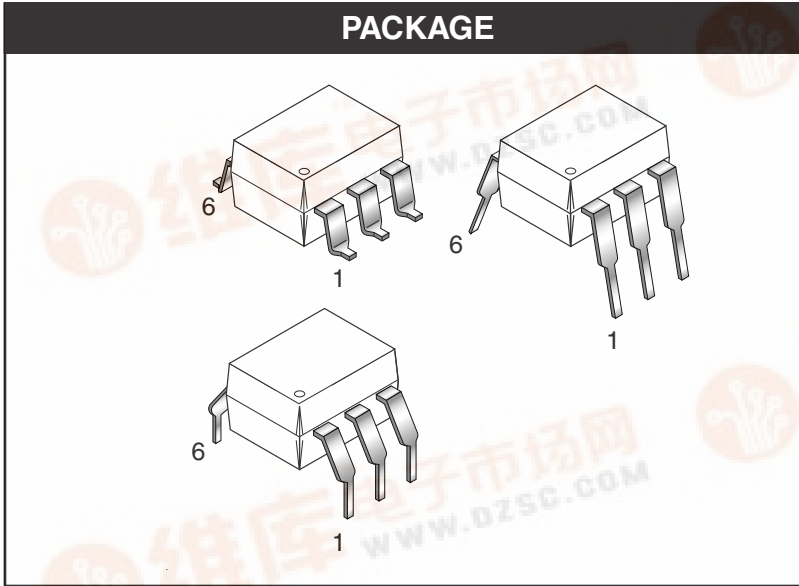

## SCHEMATIC

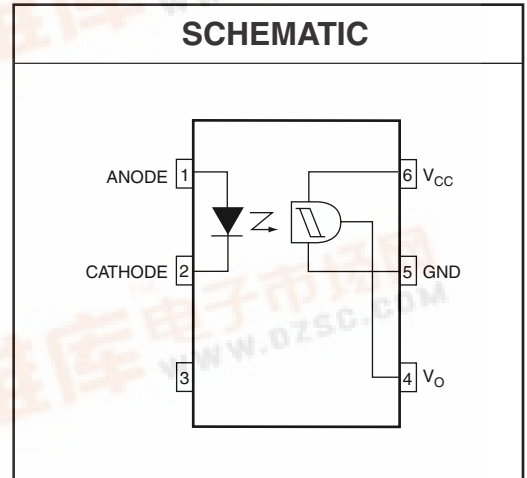

## DESCRIPTION

The H11LXM series has a high speed integrated circuit detector optically coupled to a gallium-arsenide infrared emitting diode. The output incorporates a Schmitt trigger, which provides hysteresis for noise immunity and pulse shaping. The detector circuit is optimized for simplicity of operation and utilizes an open collector output for maximum application flexibility.

## Truth Table

Input	Output
H	L
L	H

## FEATURES

- High data rate, 1 MHz typical (NRZ)
- Free from latch up and oscillation throughout voltage and temperature ranges.
- Microprocessor compatible drive
- Logic compatible output sinks 16 mA at 0.4 V maximum
- Guaranteed on/off threshold hysteresis
- Wide supply voltage capability, compatible with all popular logic systems
- Underwriters Laboratory (UL) recognized—file #E90700, Volume 2
- VDE recognized – File#102497 – Add option V (e.g., H11L1VM)

## APPLICATIONS

- Logic to logic isolator
- Programmable current level sensor
- Line receiver—eliminate noise and transient problems
- A.C. to TTL conversion—square wave shaping
- Digital programming of power supplies
- Interfaces computers with peripherals

**H11L1M**

**H11L2M**

**H11L3M**

**ABSOLUTE MAXIMUM RATINGS**

Parameters	Symbol	Device	Value	Units
<b>TOTAL DEVICE</b>				
Storage Temperature	$T_{STG}$	All	-55 to +150	°C
Operating Temperature	$T_{OPR}$	All	-40 to +85	°C
Lead Solder Temperature	$T_{SOL}$	All	260 for 10 sec	°C
Total Device Power Dissipation @ 25°C Derate Above 25°C	$P_D$	All	250 2.94	mW mW/°C
<b>EMITTER</b>				
Continuous Forward Current	$I_F$	All	60	mA
Reverse Voltage	$V_R$	All	6	V
Forward Current - Peak (1 $\mu$ s pulse, 300 pps)	$I_F(pk)$	All	3.0	A
LED Power Dissipation 25°C Ambient Derate Linearly From 25°C	$P_D$	All	120 1.41	mW mW/°C
<b>DETECTOR</b>				
Detector Power Dissipation @ 25°C Derate Linearly from 25°C	$P_D$	All	150 2.0	mW mW/°C
$V_{45}$ Allowed Range	$V_O$	All	0 to 16	V
$V_{65}$ Allowed Range	$V_{CC}$	All	3 to 16	V
$I_4$ Output Current	$I_O$	All	50	mA

**ELECTRICAL CHARACTERISTICS** ( $T_A = 25^\circ\text{C}$  Unless otherwise specified.)

**INDIVIDUAL COMPONENT CHARACTERISTICS**

Parameters	Test Conditions	Symbol	Device	Min	Typ	Max	Units
<b>EMITTER</b>							
Input Forward Voltage	$I_F = 10\text{ mA}$	$V_F$	All		1.2	1.5	V
	$I_F = 0.3\text{ mA}$			0.75	1.0		
Reverse Current	$V_R = 3\text{ V}$	$I_R$	All			10	$\mu\text{A}$
Capacitance	$V = 0, f = 1.0\text{ MHz}$	$C_J$	All			100	pF
<b>DETECTOR</b>							
Operating Voltage Range		$V_{CC}$	All	3		15	V
Supply Current	$I_F = 0, V_{CC} = 5\text{ V}$	$I_{CC(off)}$	All		1.6	5.0	mA
Output Current, High	$I_F = 0, V_{CC} = V_O = 15\text{ V}$	$I_{OH}$	All			100	$\mu\text{A}$

**H11L1M**

**H11L2M**

**H11L3M**

**ISOLATION CHARACTERISTICS**

Parameters	Test Conditions	Symbol	Min	Typ	Max	Units
Input-Output Isolation Voltage	t = 1 sec.	V <sub>ISO</sub>	7500			V <sub>PEAK</sub>
Isolation Capacitance	V <sub>I-O</sub> = 0V, f = 1 MHz	C <sub>ISO</sub>		0.4	0.6	pF
Isolation Resistance	V <sub>I-O</sub> = ±500 VDC	R <sub>ISO</sub>	10 <sup>11</sup>			Ω

**TRANSFER CHARACTERISTICS**

DC Characteristics	Test Conditions	Symbol	Device	Min	Typ	Max	Units
Supply Current	I <sub>F</sub> = 10mA, V <sub>CC</sub> = 5V	I <sub>CC(on)</sub>	All		1.6	5.0	mA
Output Voltage, low	R <sub>L</sub> =270Ω, V <sub>CC</sub> =5V, I <sub>F</sub> =I <sub>F(on)</sub> max.	V <sub>OL</sub>	All		0.2	0.4	V
Turn-On Threshold Current	R <sub>L</sub> =270Ω, V <sub>CC</sub> = 5V	I <sub>F(on)</sub> *	H11L1M			1.6	mA
			H11L2M			10.0	
			H11L3M			5.0	
Turn-Off Threshold Current	R <sub>L</sub> =270Ω, V <sub>CC</sub> = 5V	I <sub>F(off)</sub>	All	0.3	1.0		mA
Hysteresis Ratio	R <sub>L</sub> =270Ω, V <sub>CC</sub> = 5V	I <sub>F(off)</sub> /I <sub>F(on)</sub>	All	0.50	0.75	0.90	
AC Characteristics	Test Conditions	Symbol	Device	Min	Typ	Max	Units
<b>SWITCHING SPEED</b>							
Turn-On time	R <sub>L</sub> =270Ω, V <sub>CC</sub> = 5V, I <sub>F</sub> =I <sub>F(on)</sub> , T <sub>A</sub> =25°C	t <sub>on</sub>	All		1.0		μs
					0.65		
						4	
Fall Time	R <sub>L</sub> =270Ω, V <sub>CC</sub> = 5V, I <sub>F</sub> =I <sub>F(on)</sub> , T <sub>A</sub> =25°C	t <sub>f</sub>	All		0.1		μs
					.05		
					0.1		
Turn-Off Time	R <sub>L</sub> =270Ω, V <sub>CC</sub> = 5V, I <sub>F</sub> =I <sub>F(on)</sub> , T <sub>A</sub> =25°C	t <sub>off</sub>	All		2.0		μs
					1.2		
						4	
Rise time	R <sub>L</sub> =270Ω, V <sub>CC</sub> = 5V, I <sub>F</sub> =I <sub>F(on)</sub> , T <sub>A</sub> =25°C	t <sub>r</sub>	All		0.1		μs
					0.07		
					0.1		
Data Rate			All		1.0		MHz

**NOTE:**

\*Maximum I<sub>F(ON)</sub> is the maximum current required to trigger the output. For example, a 1.6mA maximum trigger current would require the LED to be driven at a current greater than 1.6mA to guarantee the device will turn on. A 10% guard band is recommended to account for degradation of the LED over its lifetime. The maximum allowable LED drive current is 60mA.

**H11L1M**

**H11L2M**

**H11L3M**

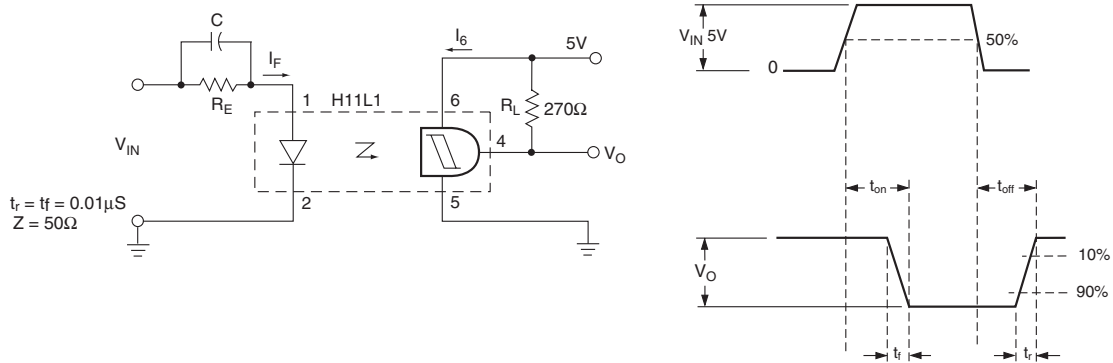

Figure 1. Switching Test Circuit and Waveforms

**TYPICAL PERFORMANCE CURVES**

Figure 2. Transfer Characteristics

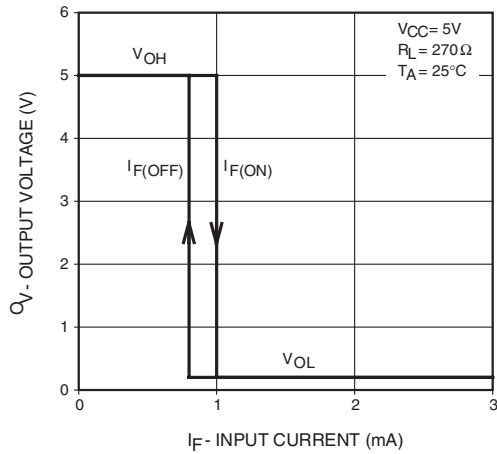

Figure 3. Threshold Current vs. Supply Voltage

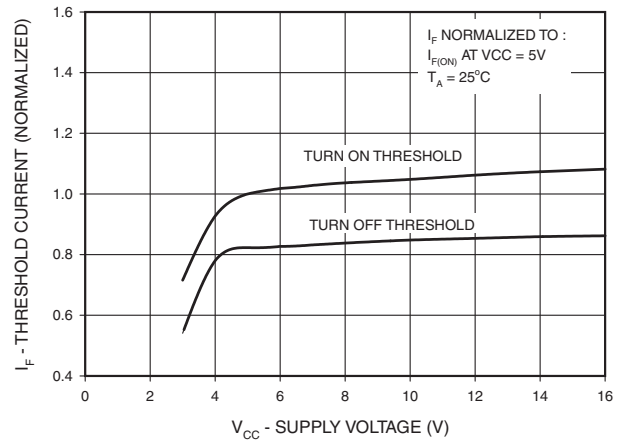

Figure 4. Threshold Current vs. Supply Temperature

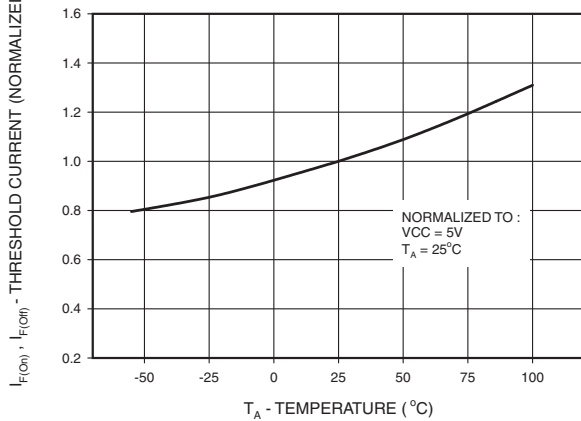
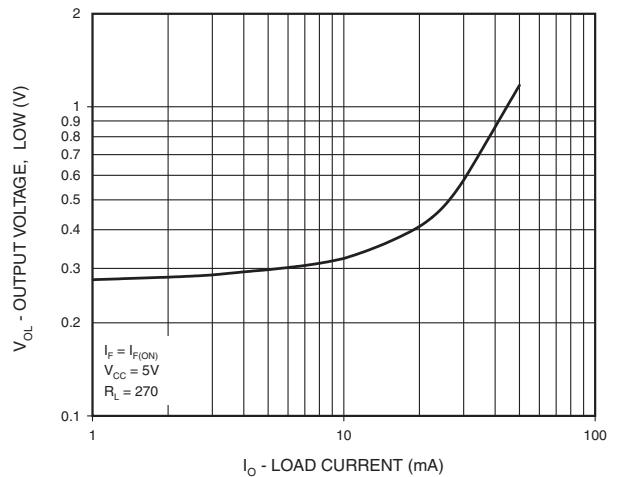

Figure 5. Output Voltage, Low vs. Load Current



**H11L1M**

**H11L2M**

**H11L3M**

**TYPICAL PERFORMANCE CURVES**

Figure 6. Supply Current vs. Supply Voltage

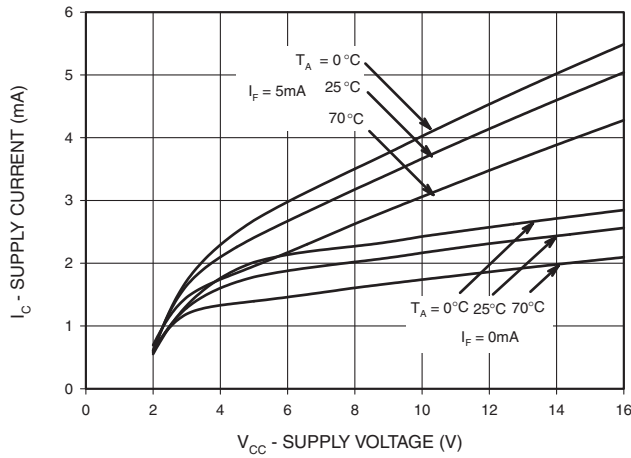
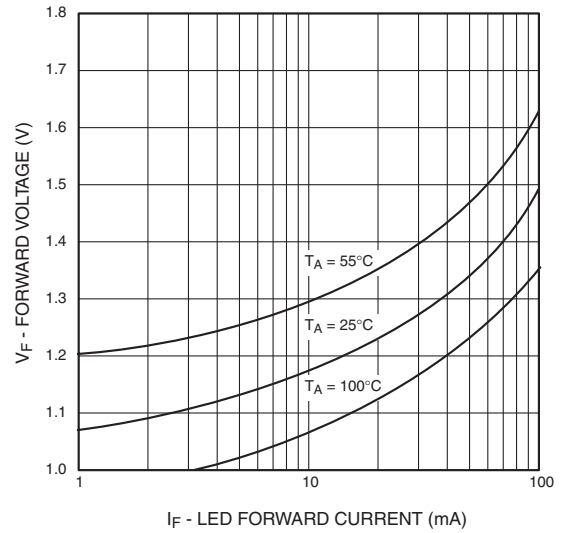

Figure 7. LED Forward Voltage vs. Forward Current





**H11L1M**

**H11L2M**

**H11L3M**

**ORDERING INFORMATION**

Option/Order Entry Identifier	Description
S	Surface Mount Lead Bend
SR2	Surface Mount; Tape and reel
T	0.4" Lead Spacing
V	VDE 0884
TV	VDE 0884, 0.4" Lead Spacing
SV	VDE 0884, Surface Mount
SR2V	VDE 0884, Surface Mount, Tape & Reel

**MARKING INFORMATION**

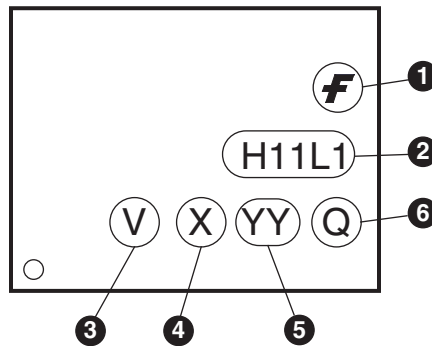

Definitions	
1	Fairchild logo
2	Device number
3	VDE mark (Note: Only appears on parts ordered with VDE option – See order entry table)
4	One digit year code, e.g., '3'
5	Two digit work week ranging from '01' to '53'
6	Assembly package code

\*Note – 'V' option parts marked with date code '325' or earlier are marked in portrait format.

H11L1M

H11L2M

H11L3M

**Carrier Tape Specifications**

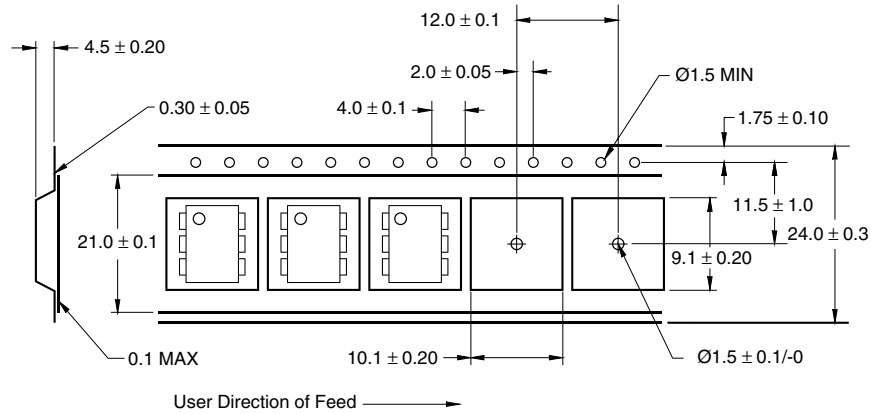

**NOTE**

All dimensions are in inches (millimeters)

**Reflow Profile**

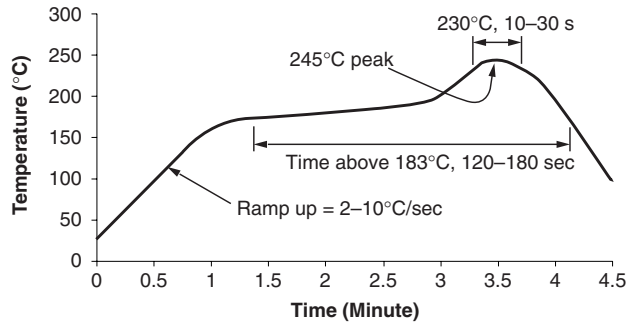

- Peak reflow temperature: 245°C (package surface temperature)
- Time of temperature higher than 183°C for 120-180 seconds
- One time soldering reflow is recommended



---

**H11L1M**

**H11L2M**

**H11L3M**

---

**DISCLAIMER**

FAIRCHILD SEMICONDUCTOR RESERVES THE RIGHT TO MAKE CHANGES WITHOUT FURTHER NOTICE TO ANY PRODUCTS HEREIN TO IMPROVE RELIABILITY, FUNCTION OR DESIGN. FAIRCHILD DOES NOT ASSUME ANY LIABILITY ARISING OUT OF THE APPLICATION OR USE OF ANY PRODUCT OR CIRCUIT DESCRIBED HEREIN; NEITHER DOES IT CONVEY ANY LICENSE UNDER ITS PATENT RIGHTS, NOR THE RIGHTS OF OTHERS.

**LIFE SUPPORT POLICY**

FAIRCHILD'S PRODUCTS ARE NOT AUTHORIZED FOR USE AS CRITICAL COMPONENTS IN LIFE SUPPORT DEVICES OR SYSTEMS WITHOUT THE EXPRESS WRITTEN APPROVAL OF THE PRESIDENT OF FAIRCHILD SEMICONDUCTOR CORPORATION. As used herein:

1. Life support devices or systems are devices or systems which, (a) are intended for surgical implant into the body, or (b) support or sustain life, and (c) whose failure to perform when properly used in accordance with instructions for use provided in the labeling, can be reasonably expected to result in a significant injury of the user.
2. A critical component in any component of a life support device or system whose failure to perform can be reasonably expected to cause the failure of the life support device or system, or to affect its safety or effectiveness.