



# L4909

## EXTERNALLY ADJUSTABLE MULTIFUNCTION REGULATOR

### ■ 3 OUTPUTS

- Vo1 : output voltage variable from 5 to 12 V;  
limit current : 1.2 A.
- Vo2 : output voltage variable from 5 to 12 V;  
limit current : 1.2 A.
- Vo3 : output voltage variable from 5 to 12 V;  
limit current : 1.2 A.

- ENABLE INPUT FOR EACH REGULATOR
- FEEDBACK INPUT FOR EACH REGULATOR
- SHORT CIRCUIT PROTECTION TO GROUND
- OVERCURRENT WARNING
- DRIVER FOR EXTERNAL SCR (CROWBAR PROTECTION)
- THERMAL SHUTDOWN

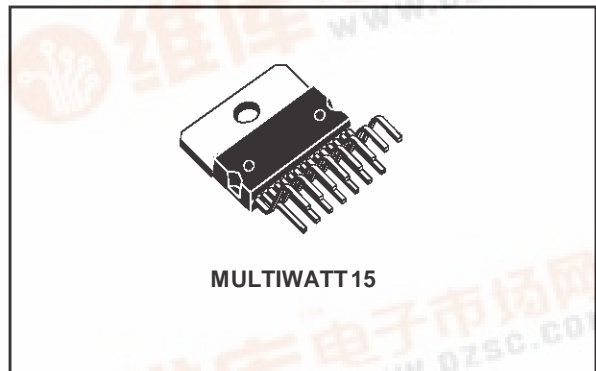

Each regulator is current limited and furthermore an OR-ed warning signal is output (open collector, active low output) when the current in a regulator goes above an over-current threshold (1 A typ for any regulator).

When one output voltage is higher than 20% typ of its nominal value (for instance in case of input-to-output short circuit), the crowbar output pin is activated, triggering an external SCR (connected between input and ground) that blows the input line fuse.

### DESCRIPTION

It is a monolithic Multifunction Voltage Regulator; it contains 3 regulators, (REG1, REG2, REG3) each one with an enable input and a feedback input, to allow the voltage setting via external resistive divider.

### BLOCK DIAGRAM

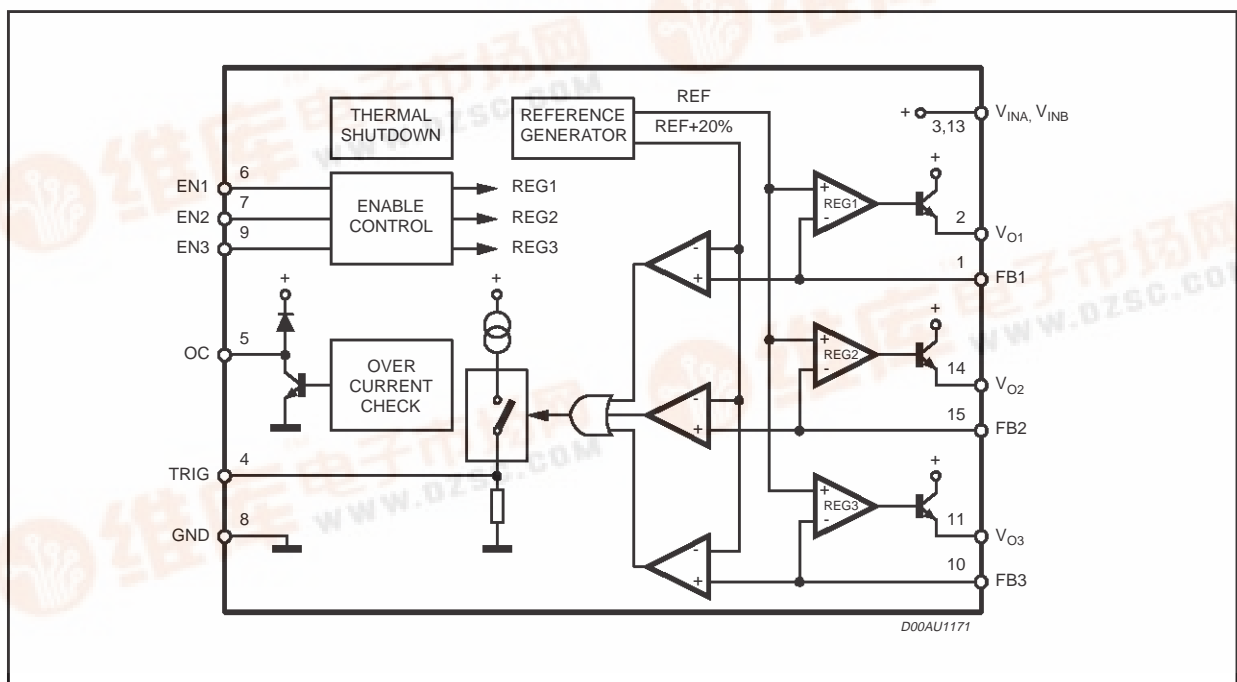

## PIN CONNECTION

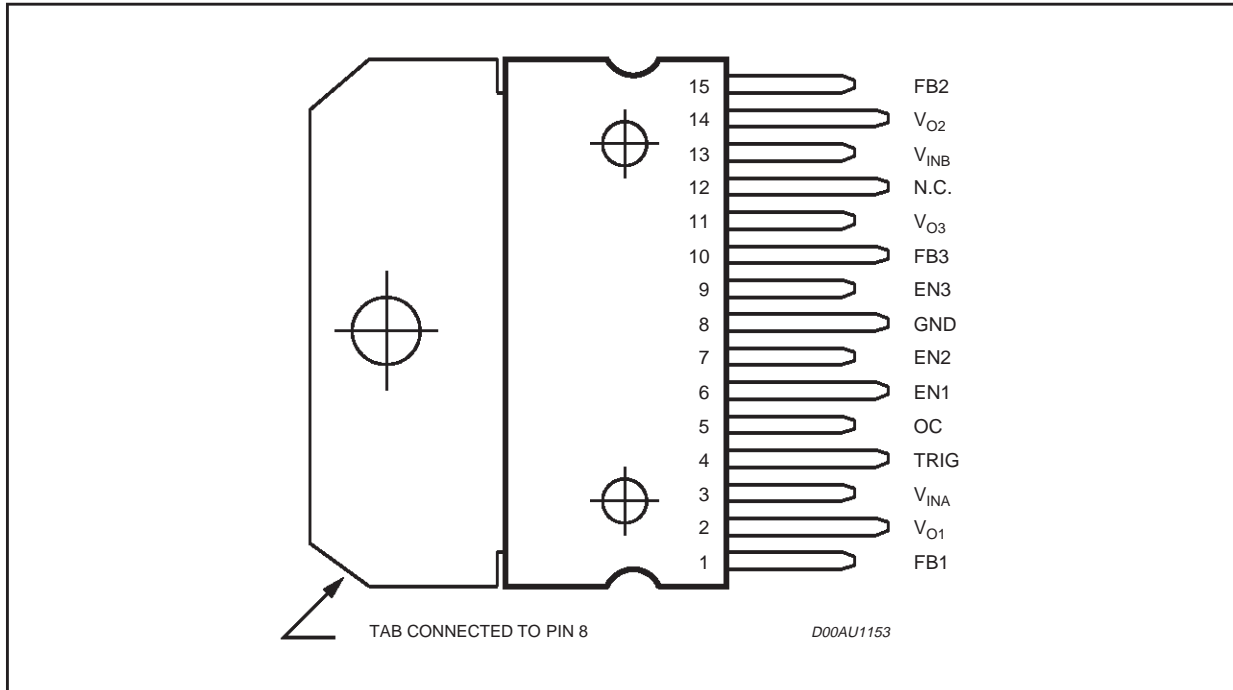

Table 1. Pin Description

No. Pin	Name	Function
1	FB1	REG1 feedback voltage input
2	Vo1	REG1 output voltage
3	VinA	Input DC supply voltage
4	TRIG	Trigger for external SCR (crowbar protection)
5	OC	Over current warning output
6	EN1	REG1 enable input
7	EN2	REG2 enable input
8	GND	Analog ground
9	EN3	REG3 enable input
10	FB3	REG3 feedback voltage input
11	Vo3	REG3 output voltage
12	N.C.	Not Connected
13	VinB	Input DC supply voltage
14	Vo2	REG2 output voltage
15	FB2	REG2 feedback voltage input

**ABSOLUTE MAXIMUM RATINGS**

Symbol	Parameter	Value	Unit
V <sub>in</sub>	VinA, VinB input DC supply voltage	40	V
I <sub>o</sub>	Vo1, Vo2, Vo3 output currents	internally limited	
V <sub>oc</sub>	OC output voltage	min (15, V <sub>in</sub> )	V
V <sub>ENx</sub>	ENx input voltage	15	V
T <sub>op</sub>	Operating temperature range	0 to 70	°C
T <sub>stg</sub>	Storage temperature	- 40 to 150	°C

**THERMAL DATA**

Symbol	Parameter	Value	Unit
R <sub>TH j-case</sub>	Thermal Resistance Junction to Case	1.8	°C/W

**ELECTRICAL CHARACTERISTICS** (C<sub>out</sub> = 100nF; V<sub>in</sub> -V<sub>o</sub> = 5V; I<sub>o</sub> = 10mA; T<sub>case</sub> = 25°C unless otherwise specified)

Symbol	Parameter	Test Condition	Min.	Typ.	Max.	Unit
V <sub>o1</sub>	REG1 output voltage range		5		12	V
V(FB1)	REG1 feedback voltage	EN1=ON;	1.22	1.27	1.32	V
I <sub>lim1</sub>	REG1 output current limit	EN1=ON; V <sub>in</sub> -V <sub>o1</sub> <12V	1.20	1.70		A
$\frac{\Delta V_{o1}}{V_{o1}}$	line regulation	I <sub>o1</sub> =10mA; V <sub>in</sub> -V <sub>o1</sub> =3 to 25 V I <sub>o1</sub> =10mA; V <sub>in</sub> -V <sub>o1</sub> =3 to 12 V		0.6 0.1	2	%
$\frac{\Delta V_{o1}}{V_{o1}}$	load regulation	I <sub>o1</sub> =10 mA to 1.2A I <sub>o1</sub> =10 mA to 0.5A		0.5 0.1	2	%
V <sub>d1</sub>	REG1 drop out	I <sub>o1</sub> =500mA			2.20	V
SVR1	REG1 supply voltage rejec.	freq=120 Hz to 1KHz	60			dB
V <sub>o2</sub>	REG2 output voltage range		5		12	V
V(FB2)	REG2 feedback voltage	EN2 = ON;	1.22	1.27	1.32	V
I <sub>lim2</sub>	REG2 output current limit	EN2=ON; V <sub>in</sub> -V <sub>o2</sub> <12V	1.20	1.70		A
$\frac{\Delta V_{o2}}{V_{o2}}$	line regulation	I <sub>o2</sub> =10mA; V <sub>in</sub> -V <sub>o2</sub> =3 to 25 V I <sub>o2</sub> =10mA; V <sub>in</sub> -V <sub>o2</sub> =3 to 12 V		0.6 0.1	2	%
$\frac{\Delta V_{o2}}{V_{o2}}$	load regulation	I <sub>o2</sub> =10 mA to 1.2A I <sub>o2</sub> =10 mA to 0.5A		0.5 0.1	2	%
V <sub>d2</sub>	REG2 drop out	I <sub>o2</sub> =500mA			2.2	V

## ELECTRICAL CHARACTERISTICS (continued)

Symbol	Parameter	Test Condition	Min.	Typ.	Max.	Unit
SVR2	REG2 supply voltage rejec.	freq=120 Hz to 1KHz	60			dB
Vo3	REG3 output voltage range		5		12	V
V(FB3)	REG3 feedback voltage	EN3=ON;	1.22	1.27	1.32	V
Ilim3	REG3 output current limit	EN3=ON; Vin-Vo3<12V	1.20	1.70		A
$\frac{\Delta V_{o3}}{V_{o3}}$	line regulation	Io3=10mA; Vin-Vo3=3 to 25 V Io3=10mA; Vin-Vo3=3 to 12 V		0.6 0.1	2	%
$\frac{\Delta V_{o3}}{V_{o3}}$	load regulation	Io3=10 mA to 1.2A Io3=10 mA to 0.5A		0.5 0.1	2	%
Vd3	REG3 drop out	Io3=500mA			2.20	V
SVR3	REG3 supply voltage rejec.	freq=120 Hz to 1KHz	60			dB
ENx	enable input voltage (active high)	STAND_BY ON	3.5		0.8	V V
Istby	current consumption in stand_by	EN1=EN2=EN3≤0.5 V			20	μA
ITRIG	current at TRIG output	SCR trigger circuit in ON state; V(TRIG) = 2V	25			mA
ZTRIG	TRIG to GND impedance	SCR trigger circuit in OFF state		0.2		KΩ
V(FB)_TR	FBx voltage for trigger SCR on	any regulator		1.52		V
I(FB)	Feedback's input current	any regulator		2		μA
I(EN)	EN's input current	V(EN) = 5V		160		μA
Ion	current consumption in ON state (current in the external feedback resistors not included)	one regulator ON; Vo = 12V two regulators ON; Vo = 12V three regulators ON; Vo = 12V		11 20 29		mA
V_OC_L	current_warning output voltage	warning conditions Isink < 3 mA			0.40	V
I_OC_H	current_warning leakage	no warning conditions V(OC) = 15V			1	μA
I_oc/Ilim	warning threshold current / limit current	any regulator Vin - Vout <12V		0.6		

The current protection is a function of the  $V_{ce}$ , i.e. the drop between input and output voltages ( $V_{in}-V_o$ ). The shape of that relationship is shown in following figure 1.

Figure 1.

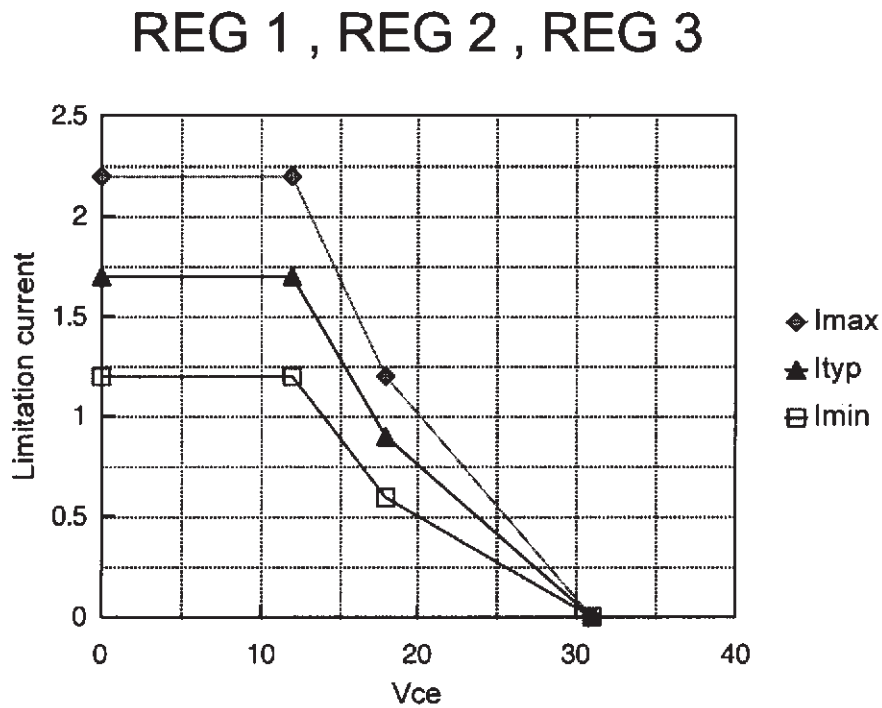
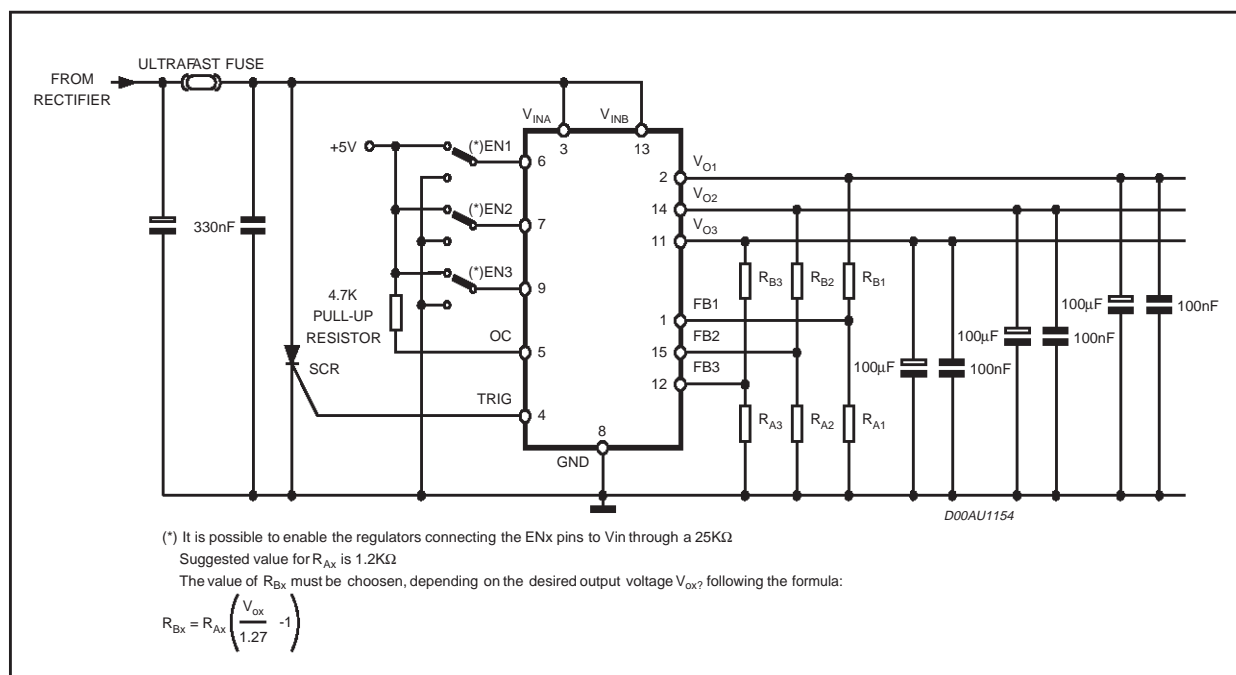
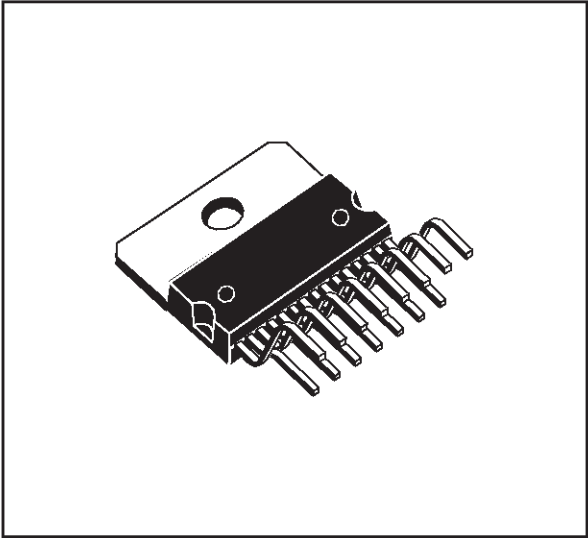

Figure 2. REGULATOR TYPICAL APPLICATION



DIM.	mm			inch		
	MIN.	TYP.	MAX.	MIN.	TYP.	MAX.
A			5			0.197
B			2.65			0.104
C			1.6			0.063
D		1			0.039	
E	0.49		0.55	0.019		0.022
F	0.66		0.75	0.026		0.030
G	1.02	1.27	1.52	0.040	0.050	0.060
G1	17.53	17.78	18.03	0.690	0.700	0.710
H1	19.6			0.772		
H2			20.2			0.795
L	21.9	22.2	22.5	0.862	0.874	0.886
L1	21.7	22.1	22.5	0.854	0.870	0.886
L2	17.65		18.1	0.695		0.713
L3	17.25	17.5	17.75	0.679	0.689	0.699
L4	10.3	10.7	10.9	0.406	0.421	0.429
L7	2.65		2.9	0.104		0.114
M	4.25	4.55	4.85	0.167	0.179	0.191
M1	4.63	5.08	5.53	0.182	0.200	0.218
S	1.9		2.6	0.075		0.102
S1	1.9		2.6	0.075		0.102
Dia1	3.65		3.85	0.144		0.152

**OUTLINE AND MECHANICAL DATA**



**Multiwatt15 V**

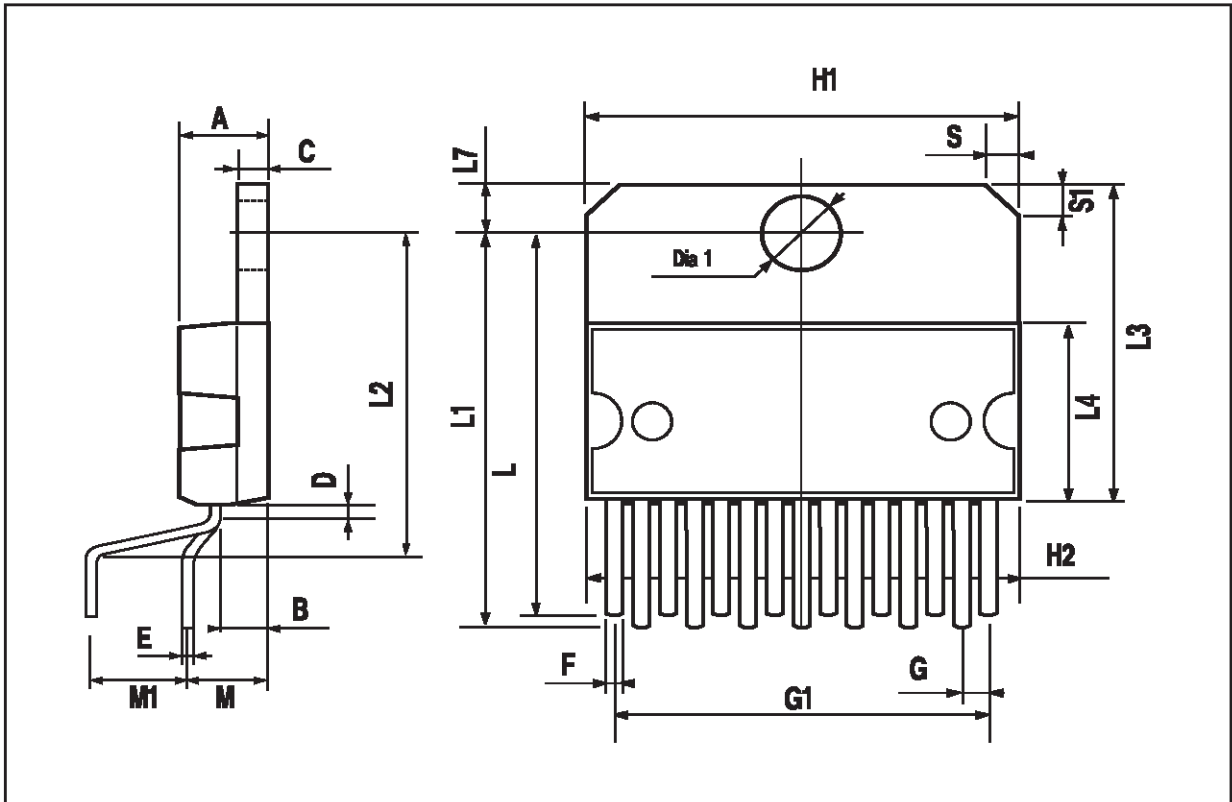

Information furnished is believed to be accurate and reliable. However, STMicroelectronics assumes no responsibility for the consequences of use of such information nor for any infringement of patents or other rights of third parties which may result from its use. No license is granted by implication or otherwise under any patent or patent rights of STMicroelectronics. Specifications mentioned in this publication are subject to change without notice. This publication supersedes and replaces all information previously supplied. STMicroelectronics products are not authorized for use as critical components in life support devices or systems without express written approval of STMicroelectronics.

The ST logo is a registered trademark of STMicroelectronics  
© 2000 STMicroelectronics - All Rights Reserved

STMicroelectronics GROUP OF COMPANIES  
Australia - Brazil - China - Finland - France - Germany - Hong Kong - India - Italy - Japan - Malaysia - Malta - Morocco - Singapore - Spain  
- Sweden - Switzerland - United Kingdom - U.S.A.  
<http://www.st.com>