



L4946B

QUAD VOLTAGE REGULATOR WITH INHIBIT AND RESET

- 4 OUTPUTS: 10V (125mA); 8.5V (250mA); 5V (200mA); 5V (100mA)
- 10V AND 5V (100mA) OUTPUT ARE LOW DROP
- 5V (100mA) ST-BY OUTPUT VOLTAGE
- EARLY WARNING OUTPUT FOR SUPPLY UNDERVOLTAGE (LVW)
- THERMAL SHUTDOWN AND CURRENT LIMITATION (FOLDBACK)
- REVERSE BATTERY AND LOAD DUMP PROTECTION
- INHIBIT (ON/OFF) AND RESET FUNCTIONS

DESCRIPTION

The L4946B is a quad output low drop voltage regulator. The four outputs are a low drop 10V at 125mA (V_{O1}), a 8.5V at 250mA (V_{O2}), a 5V at 200mA (V_{O3}) and a low drop 5V st-by line at 100mA (V_{O4}).

The IC includes a monitoring circuit to warn if a low voltage or no voltage condition is occurring. V_{O1,2,3} are off during st-by mode.

BLOCK DIAGRAM

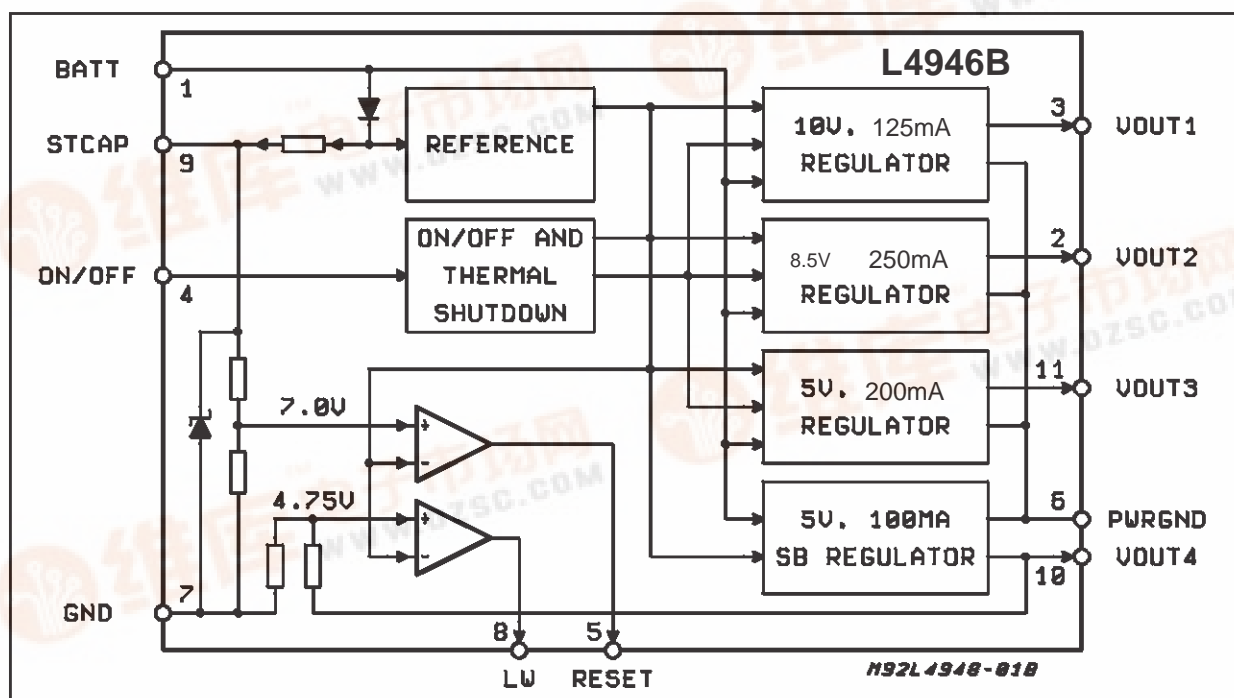

MULTIPOWER BCD TECHNOLOGY

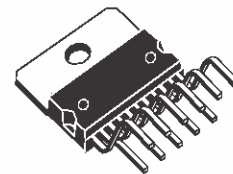

Multiwatt 11

ORDERING NUMBER: L4946B

The STCAP pin allows the battery voltage to decay slowly giving the μP time to store data. This IC is designed for supplying microcomputer controlled systems specially in automotive applications.

L4946

OPERATING CONDITION

Symbol	Parameter	Value	Unit
V_S	Supply Voltage	-13.5 to 26.5	V
I_L	Load Current I_{O1}	300	mA
	I_{O2}	400	mA
	I_{O3}	600	mA
	I_{O4}	100	mA

ABSOLUTE MAXIMUM RATINGS

Symbol	Parameter	Value	Unit
V_S	Supply Voltage	-35 to 60	V
V_I	Input Voltage (ON/OFF)	0 to 5	V
V_O	Output Voltage (LVW, Reset)	0 to 5	V
T_{stg}	Storage Temperature Range	-65 to 150	°C
T_j	Junction Temperature Range	max 150	°C
	Load Dump (5ms rise, 115ms decay)	60	V

PIN CONNECTION

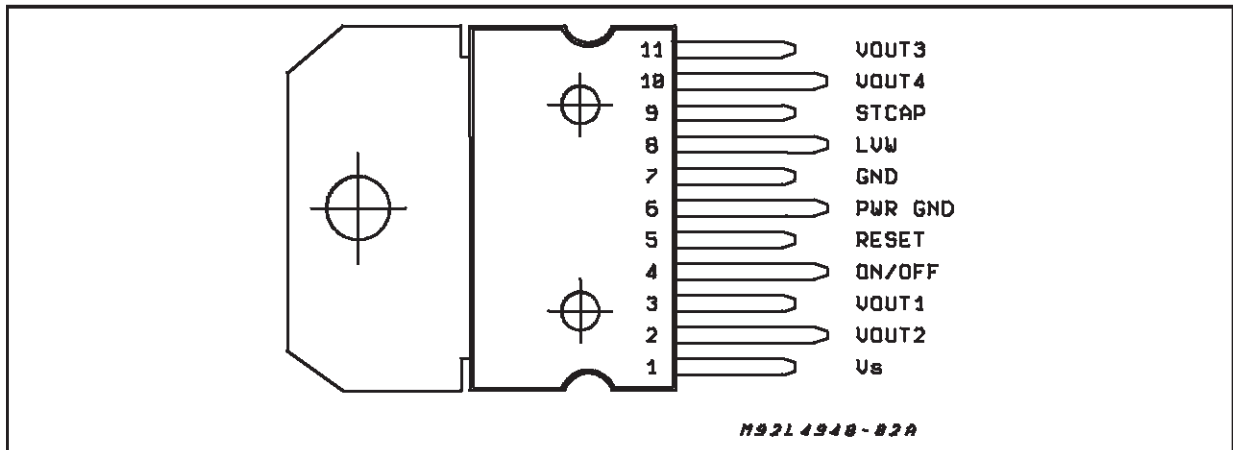

APPLICATION CIRCUIT

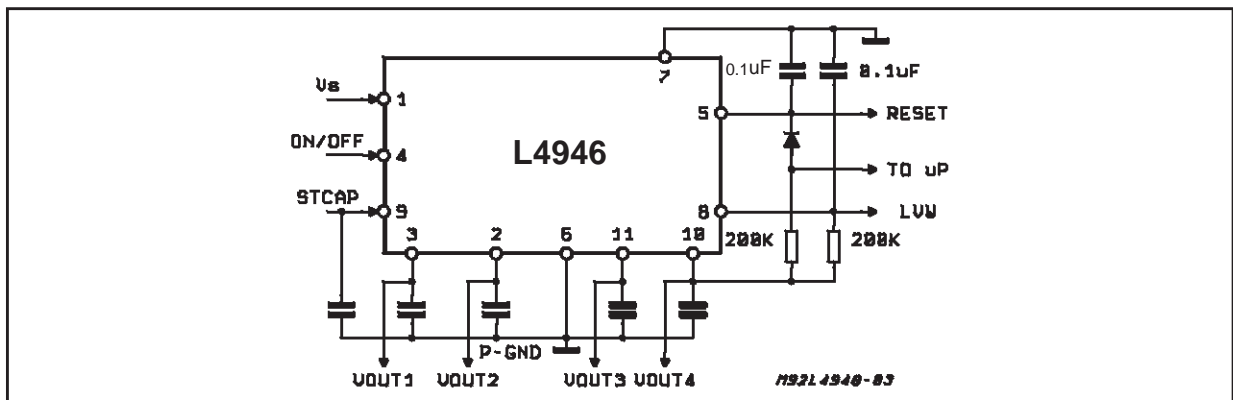

THERMAL DATA

Symbol	Parameter	Value	Unit
$R_{th\ j-case}$	Thermal Resistance Junction-case	max 2	°C/W

ELECTRICAL CHARACTERISTICS ($V_S = 10.5$ to $16V$; $I_{O1} = 6mA$, $I_{O2} = 8mA$, $I_{O3} = 4mA$; $I_{O4} = 0.4mA$; $C_O = 10\mu F$ max; $T_{amb} = -40$ to $85^\circ C$, unless otherwise specified.)

Symbol	Parameter	Test Condition	Min.	Typ.	Max.	Unit
V_{O1}	Output Voltage	$I_{O1} = 125mA$; $T_{amb} = 25^\circ C$; $11V < V_S < 16V$ all temps	9.7	10	10.3	V
			9.5	10	10.5	V
ΔV_{O1}	Load Regulation	$I_{O1} = 5$ to $125mA$			150	mV
I_Q	Quiescent Current (ΔI_S)	$V_S = 14V$; $I_{O1} = 5mA$; $V_S = 14V$; $I_{O1} = 125mA$;			10	mA
					18	mA
$V_S - V_{O1}$	Dropout Voltage	$I_{O1} = 125mA$ $T_{amb} = 25^\circ C$ all temps			400 600	mV mV
I_L	Current Limit (Foldback) note1	$V_{O1} = 0V$	150		300	mA
V_{O1}	Max Bat.Trans.	$R_O = 100\Omega$ Ramp V_S from 14 to 60V in 3-5ms			11	V
		Hold V_S at 60V for 10ms Ramp V_S from 60 to 14V in 3-5ms; $T_{amb} = 25^\circ C$; all temps	9.7 9.5	10 10	10.3 10.5	V V
V_{O1}	Rev. Voltage Trans.	$V_S = -35V$; $t \leq 1ms$; $R_O = 100\Omega$ Check V_{O1} , $T_{amb} = 25^\circ C$; all temps	9.7 9.5	10 10	10.3 10.5	V V
V_{O1}	Rev. Voltage .	$V_S = -15V$; $R_O = 100\Omega$	-0.4		1	V
	Ripple rejection (by design only)	$f_O = 120-10KHz$; $1V_{pp}AC$; $V_S = 14V$ $I_{O1} = 90mA$; $I_{O2} = 125mA$; $I_{O3} = 75mA$; $I_{O4} = 50mA$;	50			dB
		$f_O = 20-20KHz$; $1V_{pp}AC$; $V_S = 14V$ $I_{O1} = 90mA$; $I_{O2} = 125mA$; $I_{O3} = 75mA$; $I_{O4} = 50mA$;	50			dB
ΔV_{O1}	Line Regulation ΔV_{O1} across V_S range	$V_S = 11V$ to $26V$			50	mV
V_{O2}	Output Voltage	$I_{O2} = 250mA$; $T_{amb} = 25^\circ C$; all temps	7.75 7.60	8 8	8.25 8.40	V V
ΔV_{O2}	Load Regulation	$I_{O2} = 5$ to $250mA$			150	mV
ΔI_Q	Quiescent Current (ΔI_S)	$V_S = 14V$; $I_{O2} = 5mA$; $V_S = 14V$; $I_{O2} = 250mA$;			10	mA
					35	mA
$V_S - V_{O2}$	Dropout Voltage	$I_{O2} = 250mA$ $T_{amb} = 25^\circ C$ all temps			400 600	mV mV
I_L	Current Limit (note1)	$V_{O2} = 0V$	300		600	mA
V_{O2}	Max Bat.Trans.	$R_O = 100\Omega$ Ramp V_S from 14 to 60V in 3-5ms			9	V
		Hold V_S at 60V for 10ms Ramp V_S from 60 to 14V in 3-5ms; $T_{amb} = 25^\circ C$; all temps	7.85 7.60	8 8	8.15 8.20	V V
V_{O2}	Rev. Voltage Trans.	$V_S = -35V$; $t < 1ms$; $R_O = 100\Omega$ Check V_{O2} , standard $T_{amb} = 25^\circ C$ all temps	7.85 7.80	8 8	8.15 8.20	V V
V_{O2}	Rev. Voltage .	$V_S = -15V$; $t = 30s$; $R_O = 100\Omega$	-0.4		1	V

ELECTRICAL CHARACTERISTICS (continued)

Symbol	Parameter	Test Condition	Min.	Typ.	Max.	Unit
	Ripple rejection	$f_0 = 120\text{-}10\text{KHz}$; $1V_{ppAC}$; $V_S = 14V$ $I_{O1} = 90\text{mA}$; $I_{O2} = 125\text{mA}$; $I_{O3} = 75\text{mA}$; $I_{O4} = 50\text{mA}$;	50			dB
		$f_0 = 20\text{-}20\text{KHz}$; $1V_{ppAC}$; $V_S = 14V$ $I_{O1} = 90\text{mA}$; $I_{O2} = 125\text{mA}$; $I_{O3} = 75\text{mA}$; $I_{O4} = 50\text{mA}$;	50			dB
ΔV_{O2}	Line Regulation ΔV_{O2} across V_S range	$V_S = 10.5V$ to $26V$			40	mV
	Output Noise (design only)	Check output for AC noise using A weighted filter (20- 20KHz)			200	μV
		Check output for AC noise using 100kHz LP (20-100KHz)			400	μV
V_{O3}	Output Voltage	$I_{O3} = 200\text{mA}$; $T_{amb} = 25^\circ C$; all temps	4.85 4.75	5 5	5.15 5.25	V V
ΔV_{O3}	Line Regulation	$V_S = 7V$ to $26V$			40	mV
ΔV_{O3}	Load Regulation	$I_{O3} = 5$ to 200mA			100	mV
ΔI_Q	Quiescent Current (ΔI_S)	$V_S = 14V$; $I_{O3} = 5\text{mA}$; $V_S = 14V$; $I_{O3} = 200\text{mA}$;			10 25	mA mA
$V_S - V_{O3}$	Dropout Voltage	$I_{O3} = 200\text{mA}$ $T_{amb} = 25^\circ C$; all temps			400 600	mV mV
		$I_{O3} = 5\text{mA}$ set $V_S = V_{O3} + 0.3V$; $T_{amb} = 25^\circ C$; set $V_S = V_{O3} + 0.4V$; all			400 500	mV mV
I_L	Current Limit note 1	$V_{O3} = 0V$	240		480	mA
V_{O3}	Max Bat.Trans.	$R_O = 100\Omega$ Ramp V_S from 14 to 60V in 3-5ms Hold V_S at 60V for 10ms Ramp V_S from 60 to 14V in 3-5ms; $T_{amb} = 25^\circ C$; all temps	4.85 4.75	5 5	5.15 5.25	V V V V
V_{O3}	Rev. Voltage Trans.	$V_S = -35V$; $t \leq 1\text{ms}$; $R_O = 100\Omega$ Check V_{O3} , standard $T_{amb} = 25^\circ C$; all temps	4.85 4.75	5 5	5.15 5.25	V V
V_{O3}	Rev. Voltage .	$V_S = -15V$; $R_O = 100\Omega$	-0.4		1	V
	Ripple rejection	$f_0 = 120\text{-}10\text{KHz}$; $1V_{ppAC}$; $V_S = 14V$ $I_{O1} = 90\text{mA}$; $I_{O2} = 125\text{mA}$; $I_{O3} = 75\text{mA}$; $I_{O4} = 50\text{mA}$;	50			dB
		$f_0 = 10\text{KHz}$; $1V_{ppAC}$; $V_S = 14V$	50			dB
	Output Noise	Check Output for AC noise using a 100KHz LP filter Check Output for AC noise using an A weighted filter (20- 20KHz)			400 200	μV μV
V_{O4}	Output Voltage	$I_{O4} = 100\text{mA}$; $T_{amb} = 25^\circ C$; all temps	4.85 4.75	5 5	5.15 5.25	V V
ΔV_{O4}	Line Regulation	$V_S = 7V$ to $26V$			40	mV
ΔV_{O4}	Load Regulation	$I_{O4} = 0.5$ to 100mA			80	mV
ΔI_Q	Quiescent Current	$V_S = 14V$; $I_{O4} = 2\text{mA}$; $V_S = 14V$; $I_{O4} = 100\text{mA}$;			500 20	μA mA
$V_S - V_{O4}$	Dropout Voltage	$I_{O4} = 100\text{mA}$ $T_{amb} = 25^\circ C$ all temps			400 600	mV mV
I_L	Current Limit (note 1)	$V_{O4} = 0V$	120		300	mA

ELECTRICAL CHARACTERISTICS (continued)

Symbol	Parameter	Test Condition	Min.	Typ.	Max.	Unit
V _{O4}	Max Bat.Trans.	R _O = 1000Ω Ramp V _S from 14 to 60V in 3-5ms			6	V
		Hold V _S at 60V for 10ms Ramp V _S from 60 to 14V in 3-5ms; T _{amb} = 25°C; all temps	4.85 4.75	5 5	6 5.15 5.25	V V V
V _{O4}	Rev. Voltage Trans.	V _S = -35V; t < 1ms; R _O = 1000Ω Check V _{O4} , standard T _{amb} = 25°C; all temps	4.85 4.75	5 5	5.15 5.25	V V
V _{O4}	Rev. Voltage .	V _S = -15V; R _O = 1000Ω	-0.4		1	V
	Ripple rejection	f _O = 1KHz; 1V _{pp} AC; V _S = 14V I _{O1} = 90mA; I _{O2} = 125mA; I _{O3} = 75mA; I _{O4} = 50mA;	50			dB
		f _O = 10KHz; 1V _{pp} AC; V _S = 14V I _{O1} = 90mA; I _{O2} = 125mA; I _{O3} = 75mA; I _{O4} = 50mA;	50			dB
	Output Noise (design only)	Check output for AC noise using A weighted filter (20- 20KHz)			200	μV
		Check output for AC noise using 100kHz LP (20-100KHz)			400	μV
ON/OFF	Input Current	V _S = 14V; V _{IH} = >2V; V _S = 14V; V _{IL} = <0.8V;	-10		1	μA μA
V _{I ON/OFF}	Input Threshold	V _S = 14V V _{IL} V _S = 14V V _{IH}	0 2		0.8 5	V V
V _R	Reset Output Voltage Set	V _S so that V _{O4} < 4.5V; R _O = 200KΩ to V _{O4} ; V _{IL} = "0"	0		0.4	V
		V _S so that V _{O4} -0.15V; R _O = 200KΩ to V _{O4} ; V _{IH} = "1"	2.75		5	V
	Reset and LVW Output Rise Time				100	μs
	LVW Output Threshold	Ramp V _S down until LVW switches from "1" to a "0"	7.0		8.2	V
	LVW and LVW Output Fall Time				150	μs
	LVW Output Voltage	STCAP < 7V; R _O = 200KΩ to V _{O4} ; V _{IL} = "0"	0		0.4	V
		STCAP > 8V; R _O = 200KΩ to V _{O4} ; V _{IH} = "1"	2.75		5	V
	Reset Output Stability	V _S is set such that 1 ≤ V _{O4} ≤ 4V; I _{OUT4} = 2mA; V _{ON/OFF} = 0 meas reset variation			50	mV
I _q	St-By Quiescent Current (ΔI _S)	V _{ON/OFF} = 0V; I _{O4} = 100mA; V _S = 14V; I _{O1,2,3} = 0mA			20	mA
		V _{ON/OFF} = 0V; I _{O4} = 2mA; V _{bat} = 14V; I _{O1,2,3} = 0mA			500	μA
	Maximum Quiescent Current (ΔI _S)	V _S = 14V; I _{O1} = 175mA; I _{O2} = 275mA; I _{O3} = 200mA; I _{O4} = 100mA; V _O = 5V			100	mA
	STCAP Output Voltage	V _S = 24V;	15		17	V
		V _S = 60V. 1ms			18	V

Note 1:

The L4946 has "Foldback" on its outputs during current limiting. As the output loading is increasing the current supplied by the L4946 increases until a threshold is reached. When the current limiting threshold is reached, the L4946 output current will start to decrease as the loading is continuing to increase. The point where the output current start to decrease is the maximum output current.

FUNCTIONAL DESCRIPTION

The L4946 includes a monitoring circuit to warn the microprocessor if a low voltage or no voltage condition is occurring. Between 7V and 8V on the STCAP pin, the LVW output will go low. This tells the microprocessor to stop executing code and save vital information. The reset output will go low when V_{04} drops 0.15V below its typical reading. A reset will occur between a minimum of 4.5 and a maximum of 5V on V_{04} . The reset output will go

low when V_{04} drops 0.15 below its typical value. A reset will occur between a minimum of 4.5V and a maximum of 5V on V_{04} . When the V_{04} drops between 4.5 and 5V the RESET output goes low. It is very important that the RESET output doesn't go above 0.75V until the V_{04} output has gone back above 4.75V (typical). The microprocessor looks for a rising edge. So, any spike will tell the microprocessor to start operating. Once the STCAP line passes 7.5V (typical), the LVW output will also return to high state.

TIMING DIAGRAM

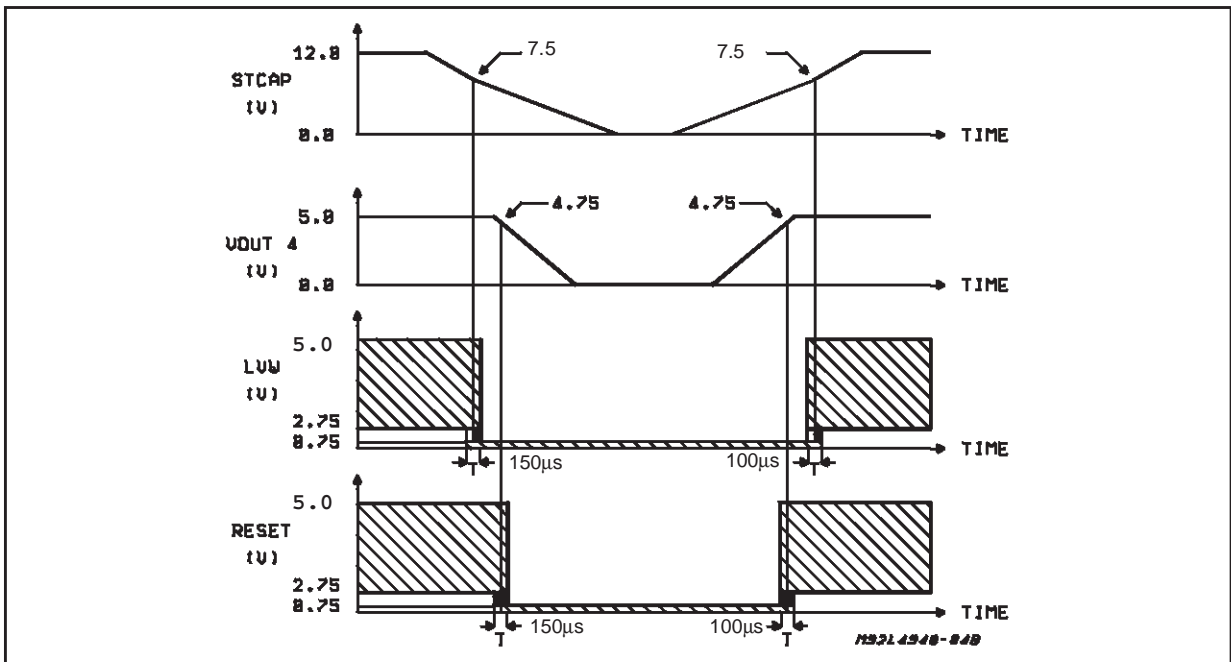

Graphs of the Output Curves for $V_{01,2,3}$ and 4

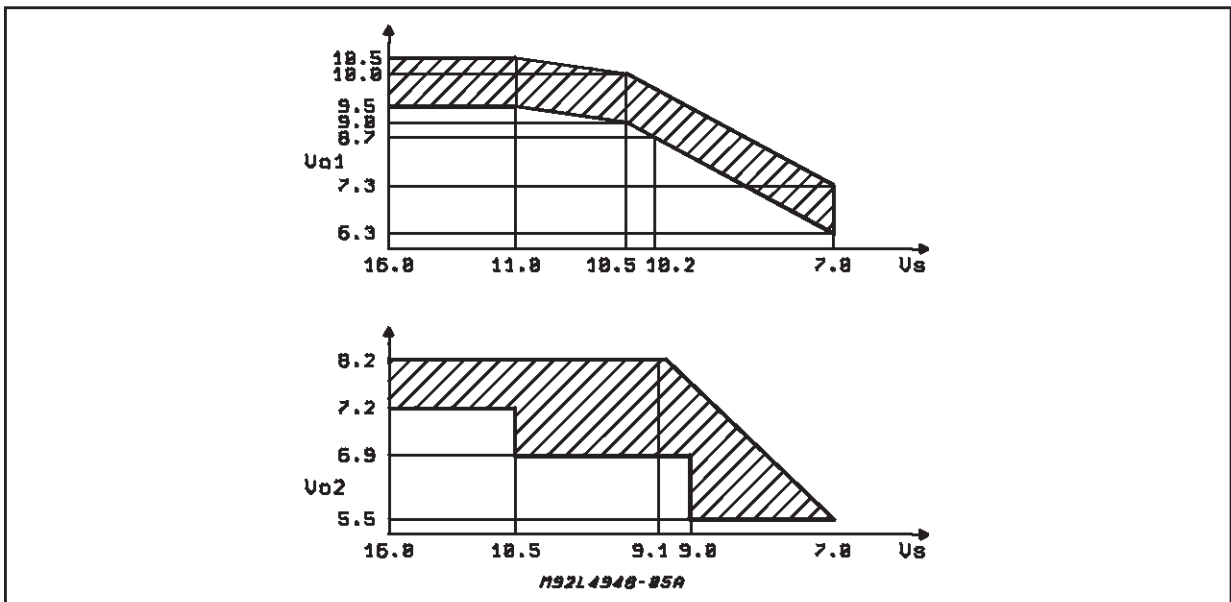

The STCAP pin acts like a delay circuit. Due to the large capacitor (470 μ F), the STCAP pin allows the battery voltage to decay slowly giving the microprocessor time to store data. Also, during short low voltage or negative voltage conditions, the STCAP pin protects the 5V st-by output from dropping below the RESET and LVW trip points. The four outputs are expected to follow the battery voltage down to 7V. At 7V typical the LVW tells the microprocessor to stop operation and

save operating data. Below 7V the outputs are expected to stay alive and ready for a return of battery.

The L4946 has a st-by mode to keep the microprocessor and memories alive during an ignition off conditions. The ON/OFF input pin is controlled by the microprocessor. An high on the ON/OFF pin places the part in normal mode. A low on the ON/OFF pin places the part in st-by mode. V_{01} , V_{02} , V_{03} will be off during st-by mode.

Graphs of the Output Curves for $V_{01,2,3}$ and 4 (Cont.)

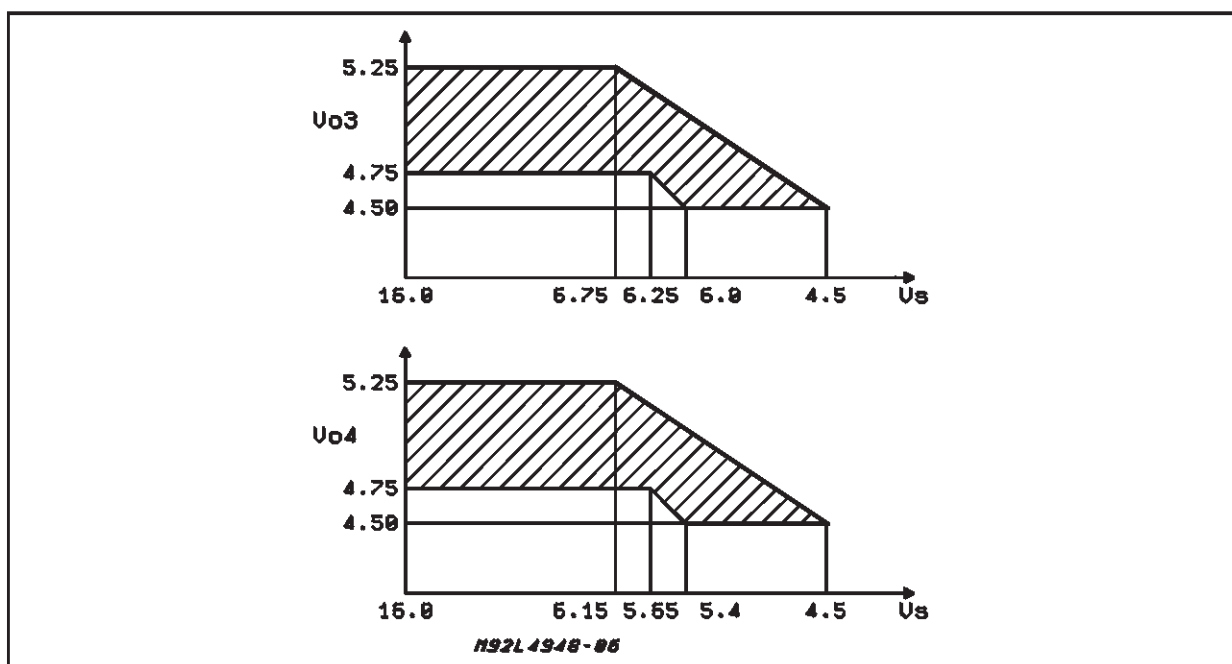

Notes and Information

The following information is for clarification, not for specification definition. Please use the information in this way.

DIM.	mm			inch		
	MIN.	TYP.	MAX.	MIN.	TYP.	MAX.
A			5			0.197
B			2.65			0.104
C			1.6			0.063
D		1			0.039	
E	0.49		0.55	0.019		0.022
F	0.88		0.95	0.035		0.037
G	1.45	1.7	1.95	0.057	0.067	0.077
G1	16.75	17	17.25	0.659	0.669	0.679
H1	19.6			0.772		
H2			20.2			0.795
L	21.9	22.2	22.5	0.862	0.874	0.886
L1	21.7	22.1	22.5	0.854	0.87	0.886
L2	17.4		18.1	0.685		0.713
L3	17.25	17.5	17.75	0.679	0.689	0.699
L4	10.3	10.7	10.9	0.406	0.421	0.429
L7	2.65		2.9	0.104		0.114
M	4.25	4.55	4.85	0.167	0.179	0.191
M1	4.73	5.08	5.43	0.186	0.200	0.214
S	1.9		2.6	0.075		0.102
S1	1.9		2.6	0.075		0.102
Dia1	3.65		3.85	0.144		0.152

OUTLINE AND MECHANICAL DATA

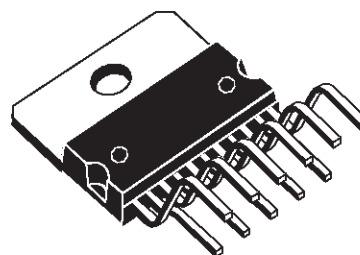

Multiwatt11 V

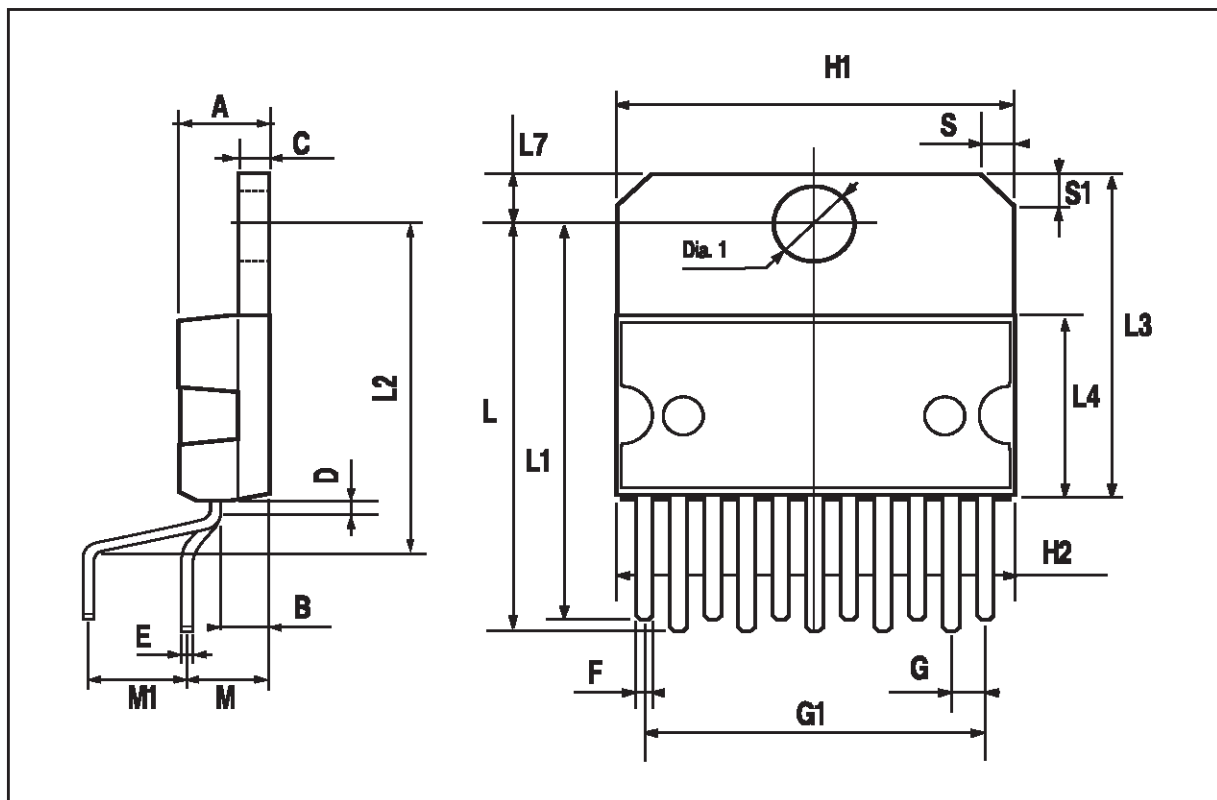

Information furnished is believed to be accurate and reliable. However, STMicroelectronics assumes no responsibility for the consequences of use of such information nor for any infringement of patents or other rights of third parties which may result from its use. No license is granted by implication or otherwise under any patent or patent rights of STMicroelectronics. Specification mentioned in this publication are subject to change without notice. This publication supersedes and replaces all information previously supplied. STMicroelectronics products are not authorized for use as critical components in life support devices or systems without express written approval of STMicroelectronics.

The ST logo is a registered trademark of STMicroelectronics

© 2000 STMicroelectronics – Printed in Italy – All Rights Reserved

STMicroelectronics GROUP OF COMPANIES

Australia - Brazil - China - Finland - France - Germany - Hong Kong - India - Italy - Japan - Malaysia - Malta - Morocco - Singapore - Spain - Sweden - Switzerland - United Kingdom - U.S.A.

<http://www.st.com>