



MOTOROLA

Advanced Information

Multifunction Very Low Dropout Voltage Regulator

The L4949 is a monolithic integrated 5.0 V voltage regulator with a very low dropout and additional functions such as power-on reset and input voltage sense.

It is designed for supplying the micro-computer controlled systems especially in automotive applications.

- Operating DC Supply Voltage Range 5.0 V to 28 V
- Transient Supply Voltage Up to 40 V
- Extremely Low Quiescent Current in Standby Mode
- High Precision Standby Output Voltage 5.0 V \pm 1%
- Output Current Capability Up to 100 mA
- Very Low Dropout Voltage Less Than 0.4 V
- Reset Circuit Sensing The Output Voltage
- Programmable Reset Pulse Delay With External Capacitor
- Voltage Sense Comparator
- Thermal Shutdown and Short Circuit Protections

L4949

MULTIFUNCTION VERY LOW DROPOUT VOLTAGE REGULATOR

SILICON MONOLITHIC
INTEGRATED CIRCUIT

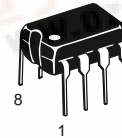

N SUFFIX
PLASTIC PACKAGE
CASE 626



D SUFFIX
PLASTIC PACKAGE
CASE 751

Representative Block Diagram

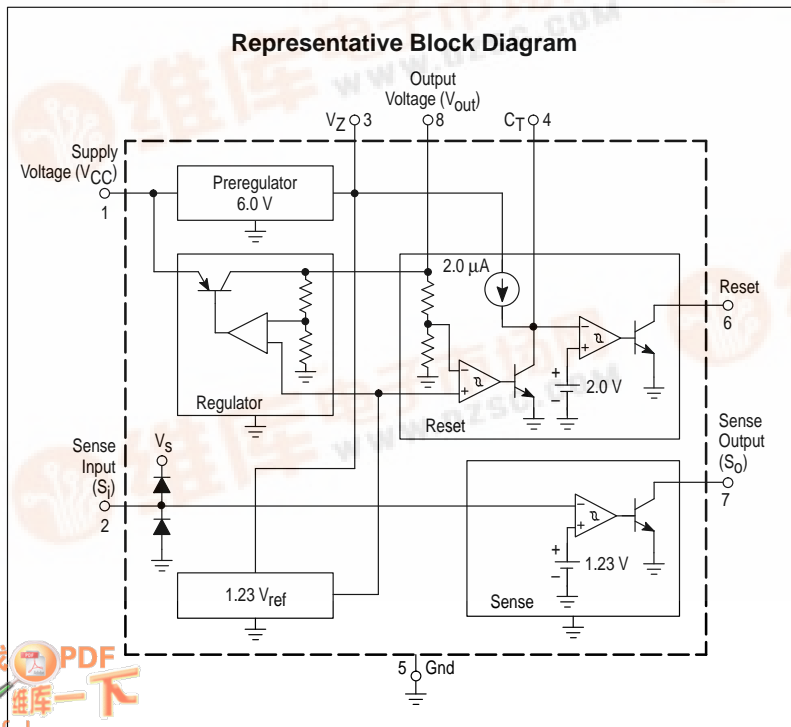

PIN CONNECTIONS

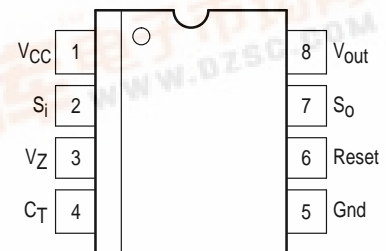

(Top View)

ORDERING INFORMATION

Device	Operating Temperature Range	Package
L4949N	$T_J = -40^\circ \text{ to } +125^\circ \text{C}$	DIP-8
L4949D		SO-8

L4949

ABSOLUTE MAXIMUM RATINGS (Absolute Maximum Ratings indicate limits beyond which damage to the device may occur.)

Rating	Symbol	Value	Unit
DC Operating Supply Voltage	V_{CC}	28	V
Transient Supply Voltage ($t < 1.0$ s)	$V_{CC\ TR}$	40	V
Output Current	I_{out}	Internally Limited	–
Output Voltage	V_{out}	20	V
Sense Input Current	I_{SI}	± 1.0	mA
Sense Input Voltage	V_{SI}	V_{CC}	–
Output Voltages Reset Output Sense Output	V_{Reset} V_{SO}	20 20	V
Output Currents Reset Output Sense Output	I_{Reset} I_{SO}	5.0 5.0	mA
Preregulator Output Voltage	V_Z	7.0	V
Preregulator Output Current	I_Z	5.0	mA
ESD Protection at any pin Human Body Model Machine Model	– –	2000 400	V
Thermal Resistance, Junction-to-Air P Suffix, DIP-8 Plastic Package, Case 626 D Suffix, SO-8 Plastic Package, Case 751	$R_{\theta JA}$	100 200	$^{\circ}C/W$
Maximum Junction Temperature	T_J	150	$^{\circ}C$
Storage Temperature Range	T_{stg}	–65 to +150	$^{\circ}C$

NOTE: ESD data available upon request.

ELECTRICAL CHARACTERISTICS ($V_{CC} = 14$ V, $-40^{\circ}C < T_J < 125^{\circ}C$, unless otherwise specified.)

Characteristic	Symbol	Min	Typ	Max	Unit
Output Voltage ($T_J = 25^{\circ}C$, $I_{out} = 1.0$ mA)	V_{out}	4.95	5.0	5.05	V
Output Voltage (6.0 V $< V_{CC} < 28$ V, 1.0 mA $< I_{out} < 50$ mA)	V_{out}	4.9	5.0	5.1	V
Output Voltage ($V_{CC} = 35$ V, $t < 1.0$ s, 1.0 mA $< I_{out} < 50$ mA)	V_{out}	4.9	5.0	5.1	V
Dropout Voltage $I_{out} = 10$ mA $I_{out} = 50$ mA $I_{out} = 100$ mA	V_{drop}	– – –	0.1 0.2 0.3	0.25 0.40 0.50	V
Input to Output Voltage Difference in Undervoltage Condition ($V_{CC} = 4.0$ V, $I_{out} = 35$ mA)	V_{IO}	–	0.2	0.4	V
Line Regulation (6.0 V $< V_{CC} < 28$ V, $I_{out} = 1.0$ mA)	Reg _{line}	–	1.0	20	mV
Load Regulation (1.0 mA $< I_{out} < 100$ mA)	Reg _{load}	–	8.0	30	mV
Current Limit $V_{out} = 4.5$ V $V_{out} = 0$ V	I_{Lim}	105 –	200 100	400 –	mA
Quiescent Current ($I_{out} = 0.3$ mA, $T_J < 100^{\circ}C$)	I_{QSE}	–	150	260	μA
Quiescent Current ($I_{out} = 100$ mA)	I_Q	–	–	5.0	mA

L4949

ELECTRICAL CHARACTERISTICS (continued) ($V_{CC} = 14\text{ V}$, $-40^\circ\text{C} < T_J < 125^\circ\text{C}$, unless otherwise specified.)

Characteristic	Symbol	Min	Typ	Max	Unit
RESET					
Reset Threshold Voltage	V_{Resth}	–	$V_{\text{out}} - 0.5$	–	V
Reset Threshold Hysteresis @ $T_J = 25^\circ\text{C}$ @ $T_J = -40$ to $+125^\circ\text{C}$	$V_{\text{Resth,hys}}$	50 50	100 –	200 300	mV
Reset Pulse Delay ($C_T = 100\text{ nF}$, $t_R \geq 100\text{ }\mu\text{s}$)	t_{ResD}	55	100	180	ms
Reset Reaction Time ($C_T = 100\text{ nF}$)	t_{ResR}	–	5.0	30	μs
Reset Output Low Voltage ($R_{\text{Reset}} = 10\text{ k}\Omega$ to V_{out} , $V_{CC} \geq 3.0\text{ V}$)	V_{ResL}	–	–	0.4	V
Reset Output High Leakage Current ($V_{\text{Reset}} = 5.0\text{ V}$)	I_{ResH}	–	–	1.0	μA
Delay Comparator Threshold	V_{CTth}	–	2.0	–	V
Delay Comparator Threshold Hysteresis	$V_{\text{CTth,hys}}$	–	100	–	mV
SENSE					
Sense Low Threshold (V_{SI} Decreasing = 1.5 V to 1.0 V)	V_{SOth}	1.16	1.23	1.35	V
Sense Threshold Hysteresis	$V_{\text{SOth,hys}}$	20	100	200	mV
Sense Output Low Voltage ($V_{\text{SI}} \leq 1.16\text{ V}$, $V_{CC} \geq 3.0\text{ V}$, $R_{\text{SO}} = 10\text{ k}\Omega$ to V_{out})	V_{SOL}	–	–	0.4	V
Sense Output Leakage ($V_{\text{SO}} = 5.0\text{ V}$, $V_{\text{SI}} \geq 1.5\text{ V}$)	I_{SOH}	–	–	1.0	μA
Sense Input Current	I_{SI}	–1.0	0.1	1.0	μA
PREREGULATOR					
Preregulator Output Voltage ($I_Z = 10\text{ }\mu\text{A}$)	V_Z	–	6.3	–	V

PIN FUNCTION DESCRIPTION

Pin	Symbol	Description
1	V_{CC}	Supply Voltage
2	S_i	Input of Sense Comparator
3	V_Z	Output of Preregulator
4	C_T	Reset Delay Capacitor
5	Gnd	Ground
6	Reset	Output of Reset Comparator
7	S_O	Output of Sense Comparator
8	V_{out}	Main Regulator Output

TYPICAL CHARACTERIZATION CURVES

Figure 1. Output Voltage versus Junction Temperature

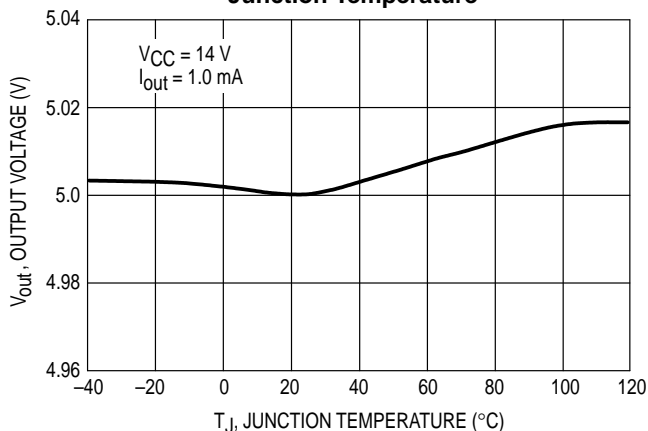
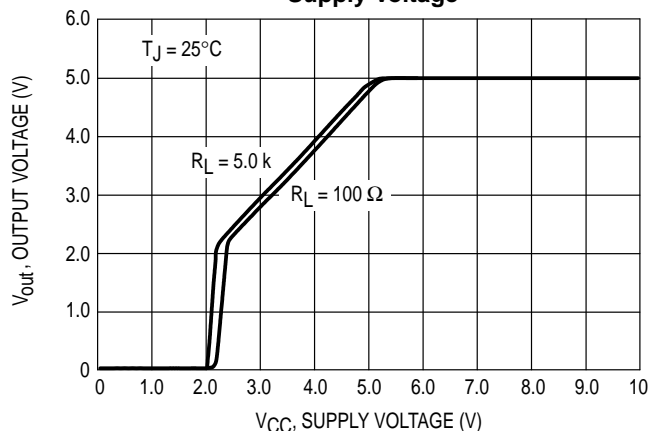

Figure 2. Output Voltage versus Supply Voltage



TYPICAL CHARACTERIZATION CURVES (continued)

Figure 3. Dropout Voltage versus Output Current

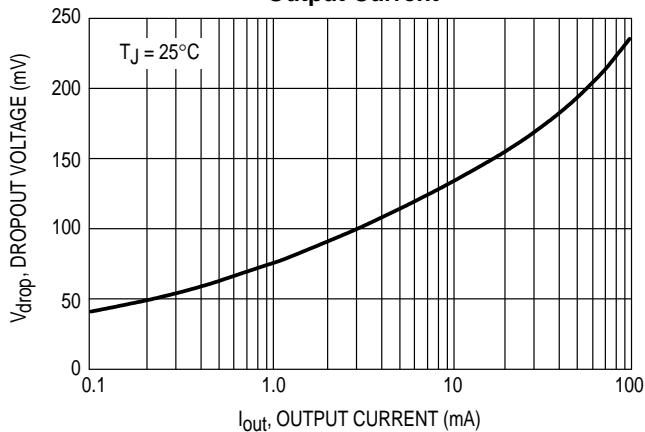

Figure 4. Dropout Voltage versus Junction Temperature

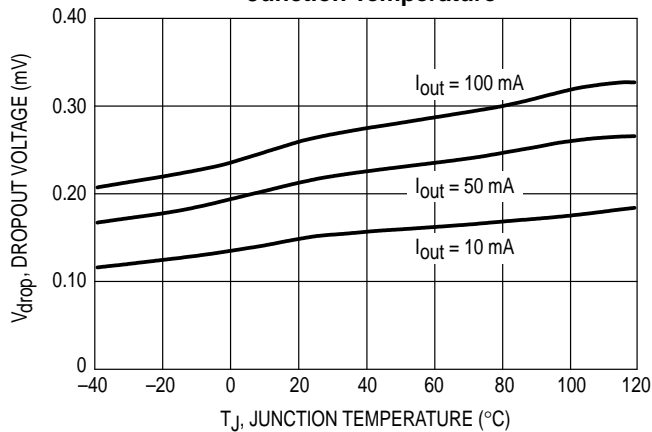

Figure 5. Quiescent Current versus Output Current

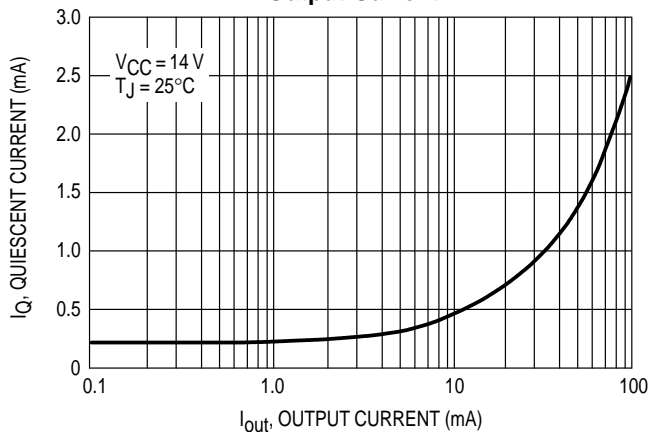

Figure 6. Quiescent Current versus Supply Voltage

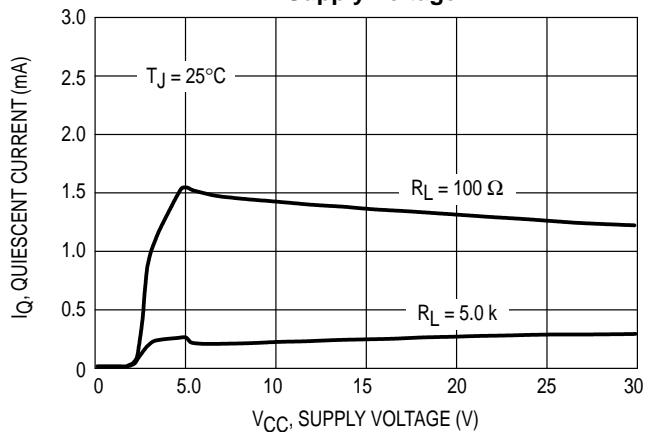

Figure 7. Reset Output versus Regulator Output Voltage

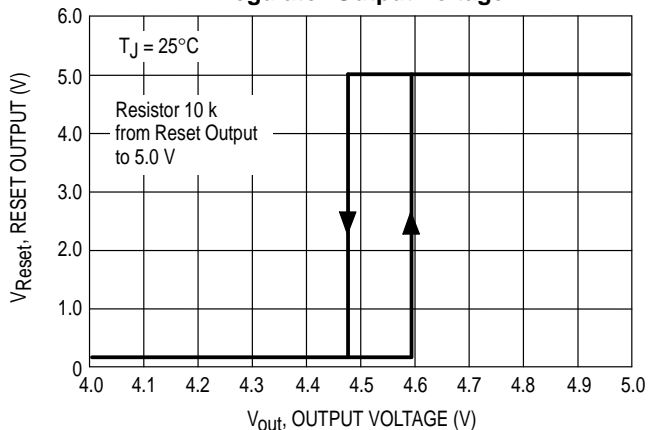
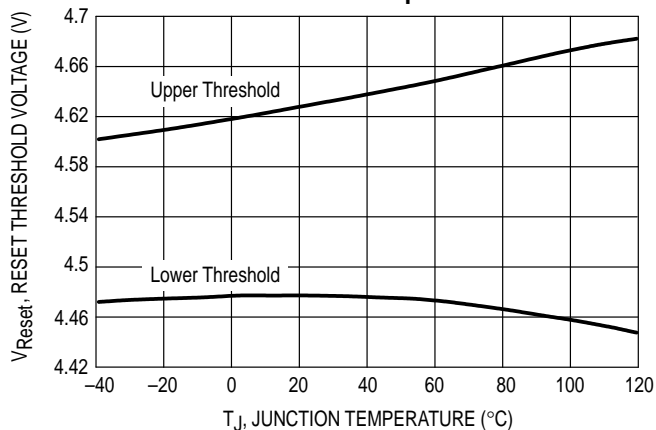

Figure 8. Reset Thresholds versus Junction Temperature



L4949

TYPICAL CHARACTERIZATION CURVES (continued)

Figure 9. Sense Output versus Sense Input Voltage

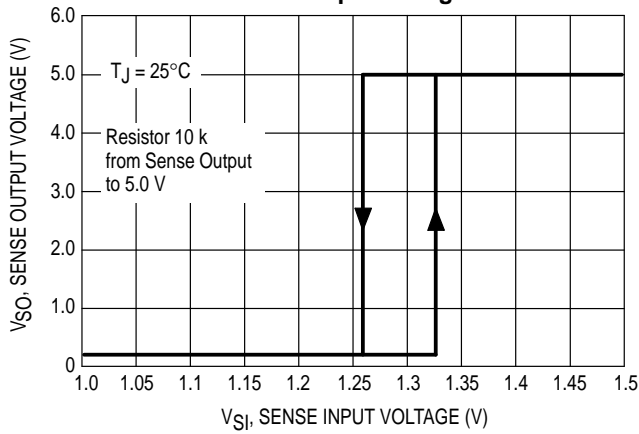
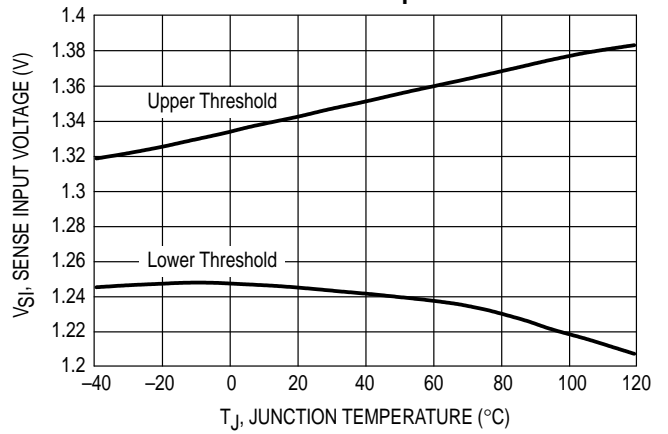

Figure 10. Sense Thresholds versus Junction Temperature



APPLICATION INFORMATION

Supply Voltage Transient

High supply voltage transients can cause a reset output signal perturbation. For supply voltages greater than 8.0 V the circuit shows a high immunity of the reset output against supply transients of more than 100 V/ μs . For supply voltages

less than 8.0 V supply transients of more than 0.4 V/ μs can cause a reset signal perturbation. To improve the transient behavior for supply voltages less than 8.0 V a capacitor at Pin 3 can be used. A capacitor at Pin 3 ($C_3 \leq 1.0 \mu\text{F}$) reduces also the output noise.

Figure 11. Application Schematic

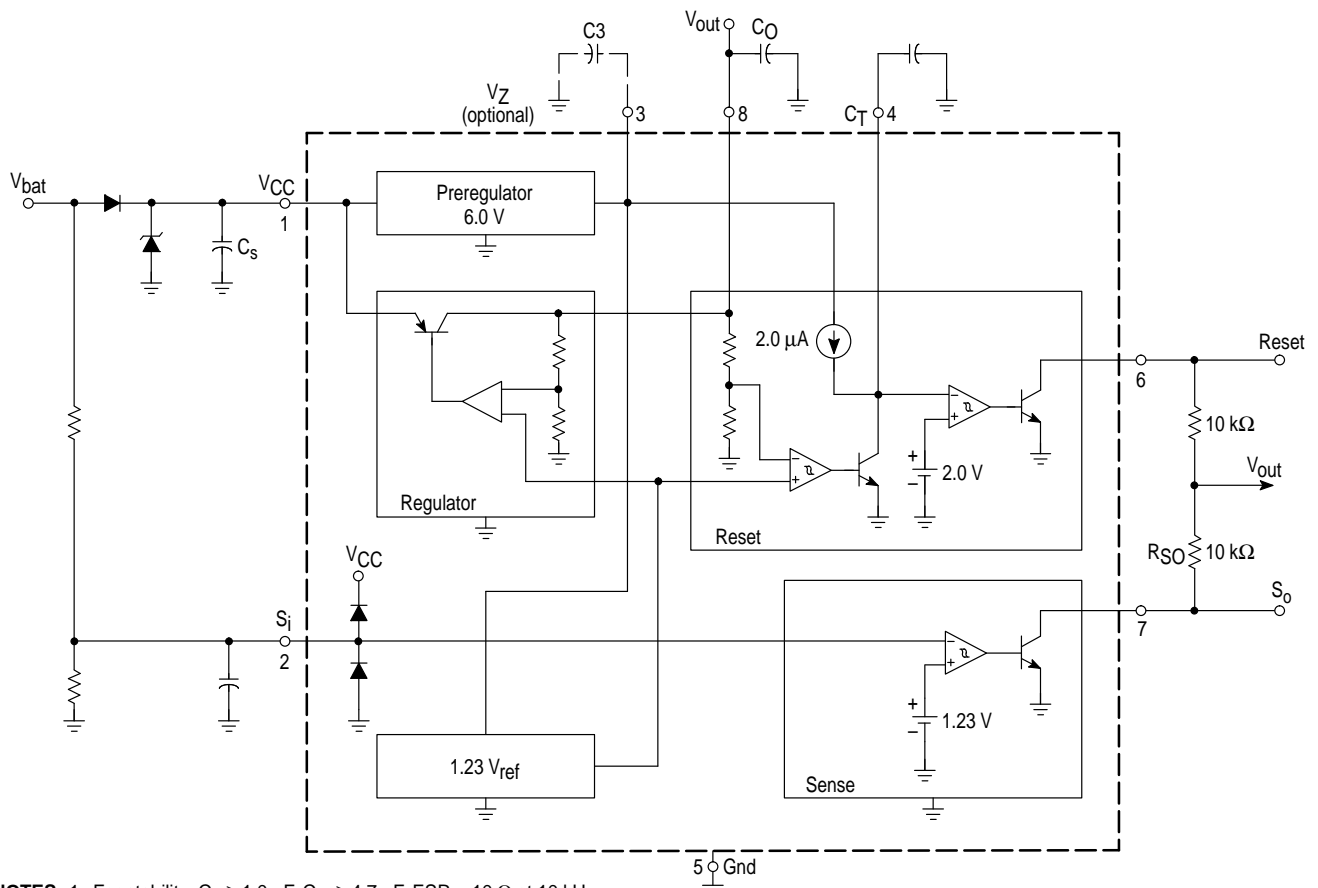

- NOTES:**
1. For stability: $C_S \geq 1.0 \mu\text{F}$, $C_0 \geq 4.7 \mu\text{F}$, $\text{ESR} < 10 \Omega$ at 10 kHz
 2. Recommended for application: $C_S = C_0 = 10 \mu\text{F}$

L4949

OPERATING DESCRIPTION

The L4949 is a monolithic integrated low dropout voltage regulator. Several outstanding features and auxiliary functions are implemented to meet the requirements of supplying microprocessor systems in automotive applications. Nevertheless, it is suitable also in other applications where the present functions are required. The modular approach of this device allows the use of other features and functions independently when required.

Voltage Regulator

The voltage regulator uses an isolated Collector Vertical PNP transistor as a regulating element. With this structure, very low dropout voltage at currents up to 100 mA is obtained. The dropout operation of the standby regulator is maintained down to 3.0 V input supply voltage. The output voltage is regulated up to the transient input supply voltage of 35 V. With this feature no functional interruption due to overvoltage pulses is generated.

The typical curve showing the standby output voltage as a function of the input supply voltage is shown in Figure 13.

The current consumption of the device (quiescent current) is less than 200 μA .

To reduce the quiescent current peak in the undervoltage region and to improve the transient response in this region, the dropout voltage is controlled. The quiescent current as a function of the supply input voltage is shown in Figure 14.

Short Circuit Protection:

The maximum output current is internally limited. In case of short circuit, the output current is foldback current limited as described in Figure 12.

Figure 12. Foldback Characteristic of V_{out}

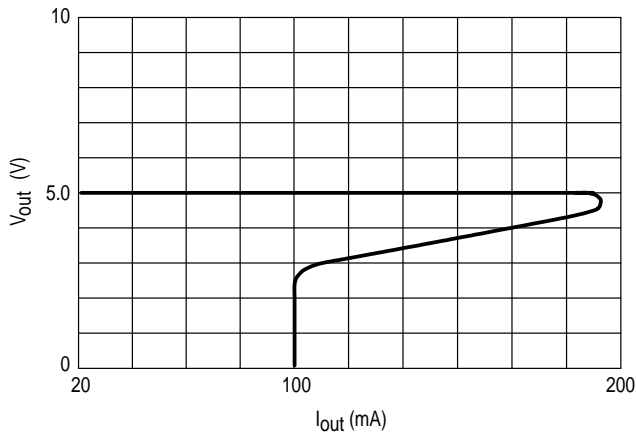

Figure 13. Output Voltage versus Supply Voltage

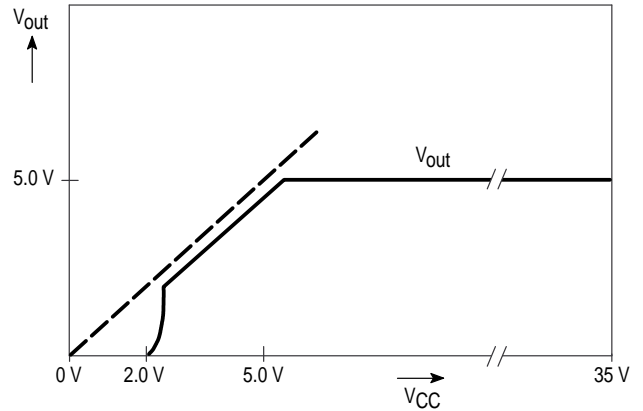
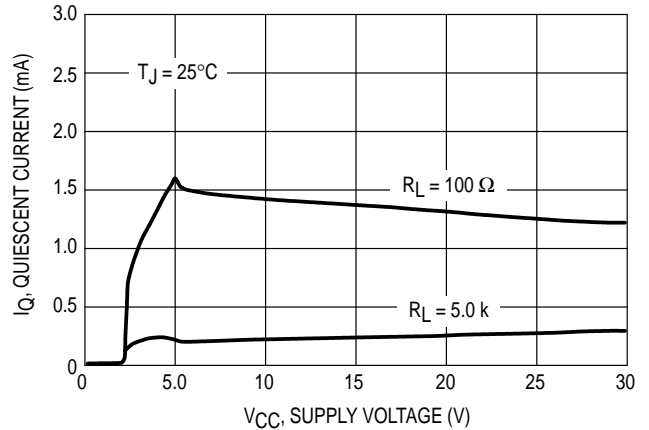

Figure 14. Quiescent Current versus Supply Voltage



Preregulator

To improve the transient immunity a preregulator stabilizes the internal supply voltage to 6.0 V. This internal voltage is present at Pin 3 (V_Z). This voltage should not be used as an output because the output capability is very small ($\leq 100 \mu\text{A}$).

This output may be used as an option when better transient behavior for supply voltages less than 8.0 V is required. In this case a capacitor (100 nF – 1.0 μF) must be connected between Pin 3 and Gnd. If this feature is not used Pin 3 must be left open.

L4949

Reset Circuit

The block circuit diagram of the reset circuit is shown in Figure 15.

The reset circuit supervises the output voltage. The reset threshold of 4.5 V is defined with the internal reference voltage and standby output divider.

The reset pulse delay time t_{RD} , is defined with the charge time of an external capacitor C_T .

$$t_{RD} = \frac{C_T \times 2.0 \text{ V}}{2.0 \text{ } \mu\text{A}}$$

The reaction time of the reset circuit originates from the discharge time limitation of the reset capacitor C_T and is proportional to the value of C_T . The reaction time of the reset circuit increases the noise immunity.

Figure 15. Reset Circuit

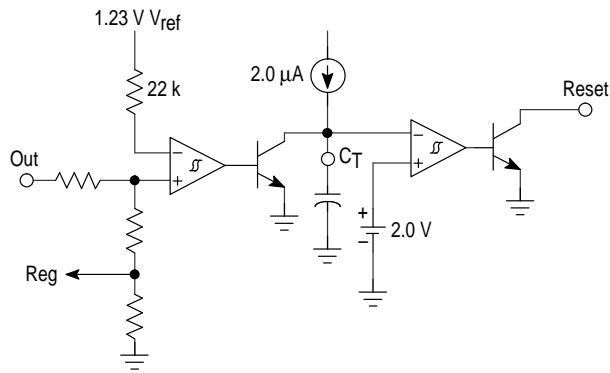

Standby output voltage drops below the reset threshold only a bit longer than the reaction time results in a shorter reset delay time.

The nominal reset delay time will be generated for standby output voltage drops longer than approximately 50 μs . The typical reset output waveforms are shown in Figure 16.

Figure 16. Typical Reset Output Waveforms

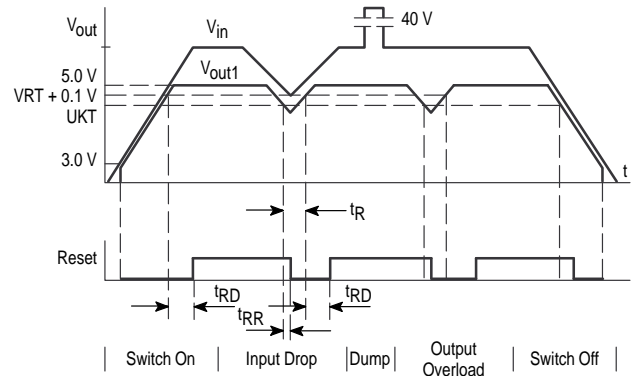

Sense Comparator

The sense comparator compares an input signal with an internal voltage reference of typical 1.23 V. The use of an external voltage divider makes this comparator very flexible in the application.

It can be used to supervise the input voltage either before or after the protection diode and to give additional information to the microprocessor like low voltage warnings.

L4949

OUTLINE DIMENSIONS

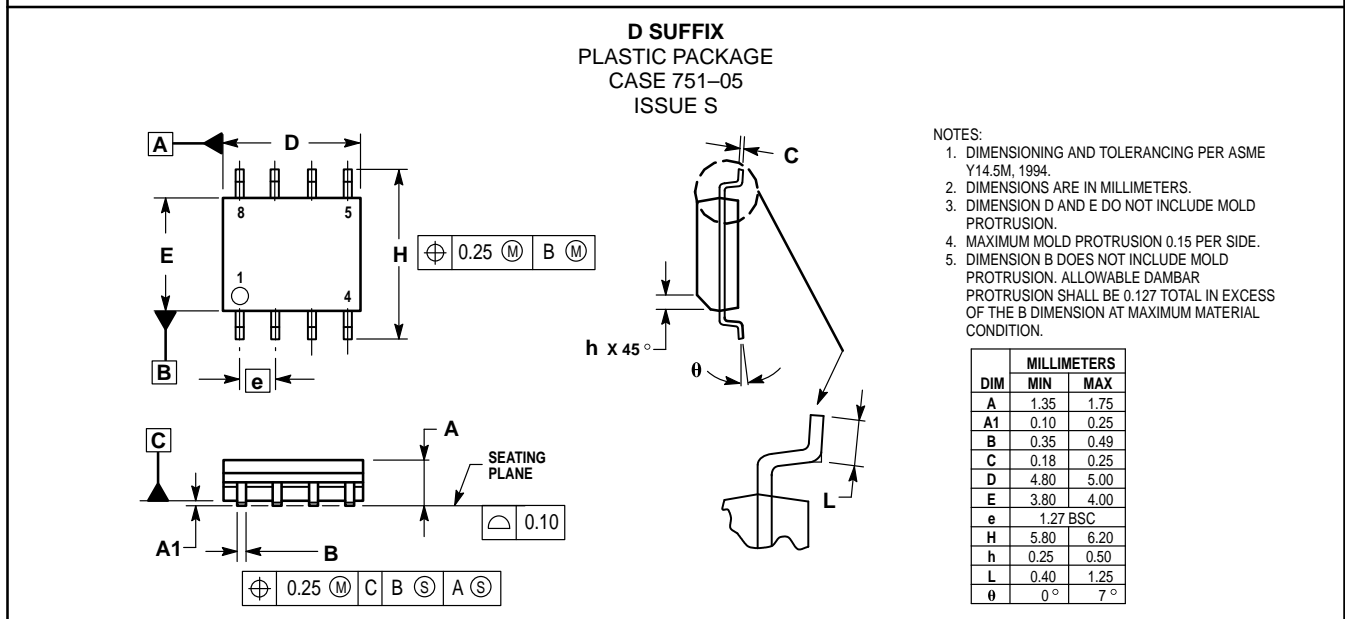
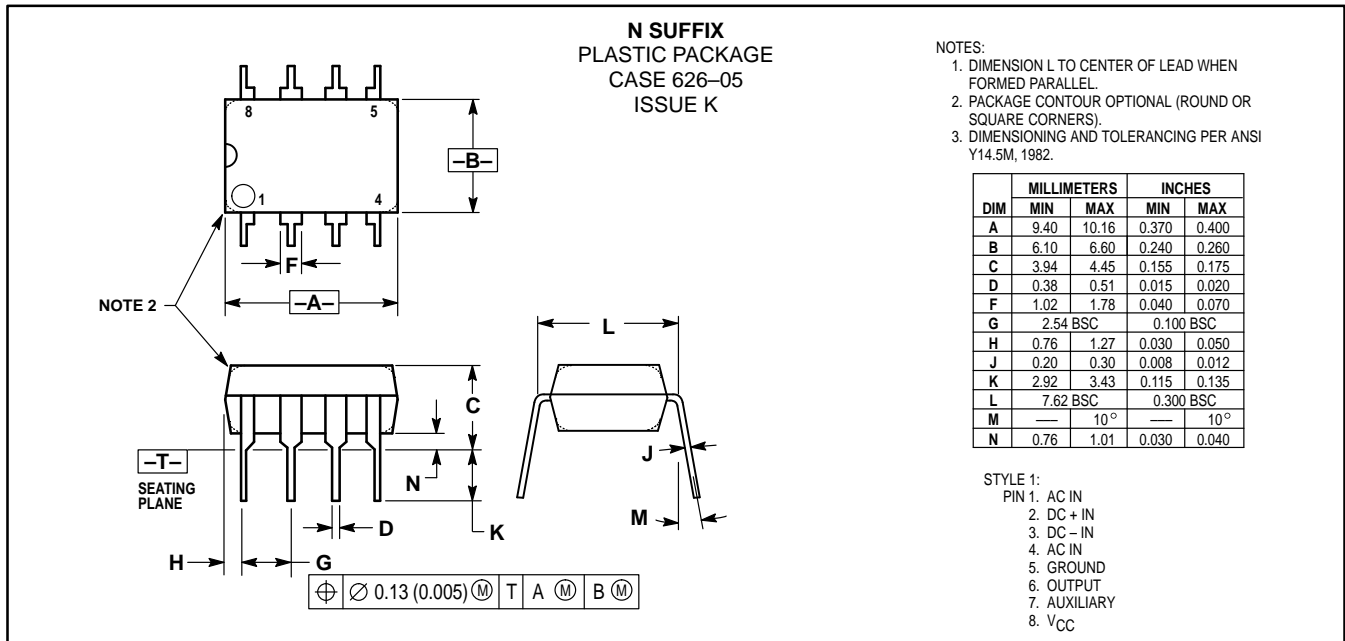

Motorola reserves the right to make changes without further notice to any products herein. Motorola makes no warranty, representation or guarantee regarding the suitability of its products for any particular purpose, nor does Motorola assume any liability arising out of the application or use of any product or circuit, and specifically disclaims any and all liability, including without limitation consequential or incidental damages. "Typical" parameters which may be provided in Motorola data sheets and/or specifications can and do vary in different applications and actual performance may vary over time. All operating parameters, including "Typicals" must be validated for each customer application by customer's technical experts. Motorola does not convey any license under its patent rights nor the rights of others. Motorola products are not designed, intended, or authorized for use as components in systems intended for surgical implant into the body, or other applications intended to support or sustain life, or for any other application in which the failure of the Motorola product could create a situation where personal injury or death may occur. Should Buyer purchase or use Motorola products for any such unintended or unauthorized application, Buyer shall indemnify and hold Motorola and its officers, employees, subsidiaries, affiliates, and distributors harmless against all claims, costs, damages, and expenses, and reasonable attorney fees arising out of, directly or indirectly, any claim of personal injury or death associated with such unintended or unauthorized use, even if such claim alleges that Motorola was negligent regarding the design or manufacture of the part. Motorola and $\textcircled{\text{M}}$ are registered trademarks of Motorola, Inc. Motorola, Inc. is an Equal Opportunity/Affirmative Action Employer.

Mfax is a trademark of Motorola, Inc.

How to reach us:

USA/EUROPE/Locations Not Listed: Motorola Literature Distribution;
P.O. Box 5405, Denver, Colorado 80217. 303-675-2140 or 1-800-441-2447

JAPAN: Nippon Motorola Ltd.: SPD, Strategic Planning Office, 4-32-1,
Nishi-Gotanda, Shinagawa-ku, Tokyo 141, Japan. 81-3-5487-8488

Mfax™: RMFAX0@email.sps.mot.com - TOUCHTONE 602-244-6609
- US & Canada ONLY 1-800-774-1848

ASIA/PACIFIC: Motorola Semiconductors H.K. Ltd.; 8B Tai Ping Industrial Park,
51 Ting Kok Road, Tai Po, N.T., Hong Kong. 852-26629298

INTERNET: <http://motorola.com/sps>

