



L585

CAR ALTERNATOR REGULATOR

- ALTERNATOR VOLTAGE CONTROL
- COMPLETE FAULT DIAGNOSTICS
- DRIVES 3 W LAMP DIRECTLY
- LAMP SHORT CIRCUIT PROTECTION
- SENSING INTERRUPT PROTECTION
- 100 V DUMP PROTECTION
- 300 V LOW ENERGY SPIKE PROTECTION
- THERMAL PROTECTION

DESCRIPTION

The L585 is an integrated circuit designed for use with an NPN darlington as a voltage regulator in a three-phase alternator charging system. It includes fault diagnostic circuitry which drives a 3 W warning lamp in fault conditions such as open or short circuit connections. Protection against load dump transients, short circuits and low energy spikes is incorporated.

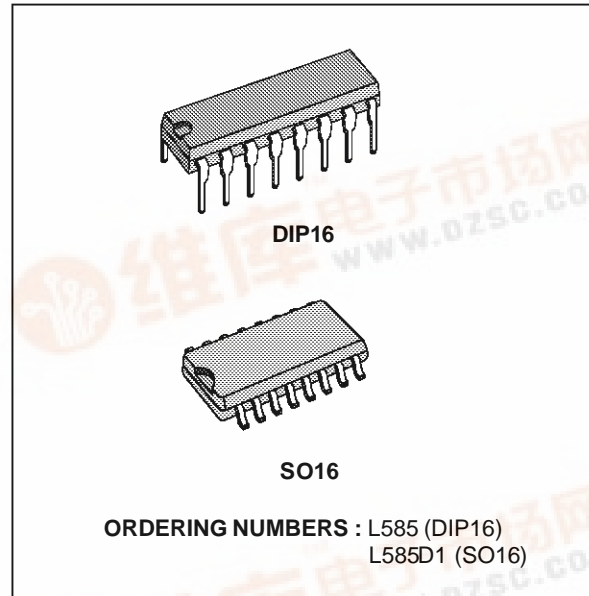

BLOCK DIAGRAM

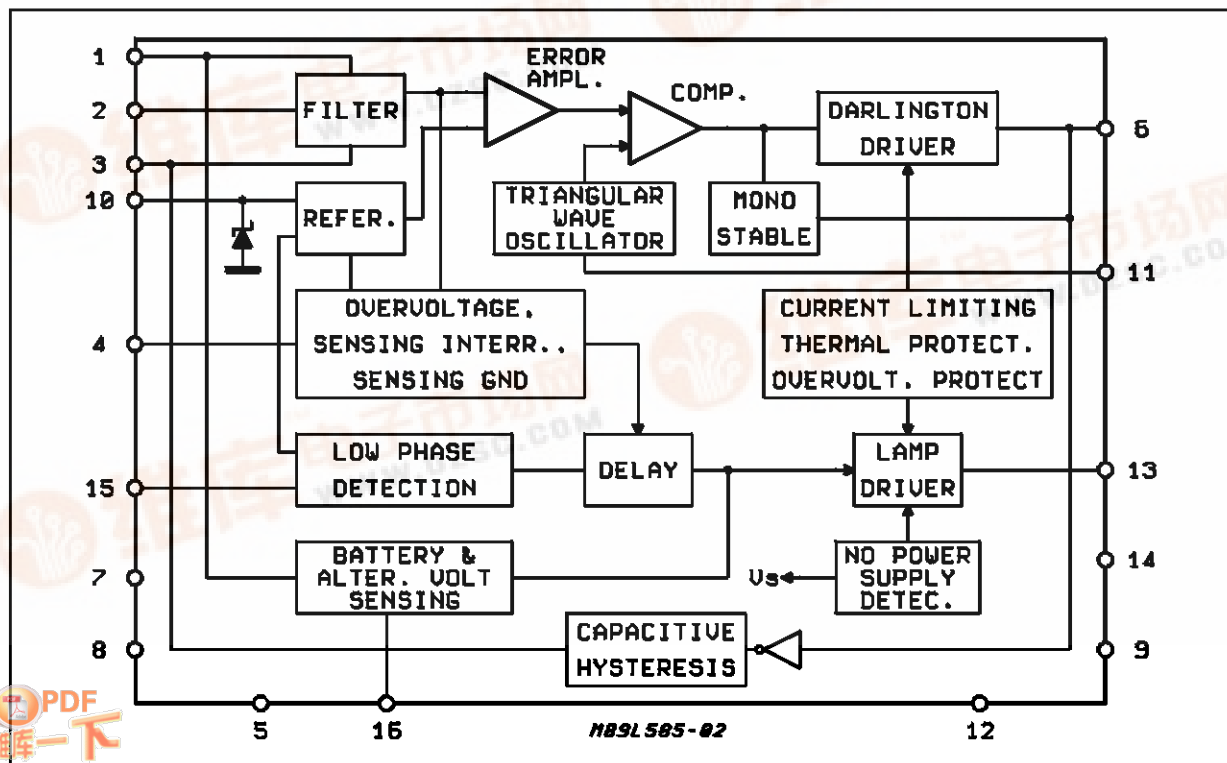

L585

PIN CONNECTION

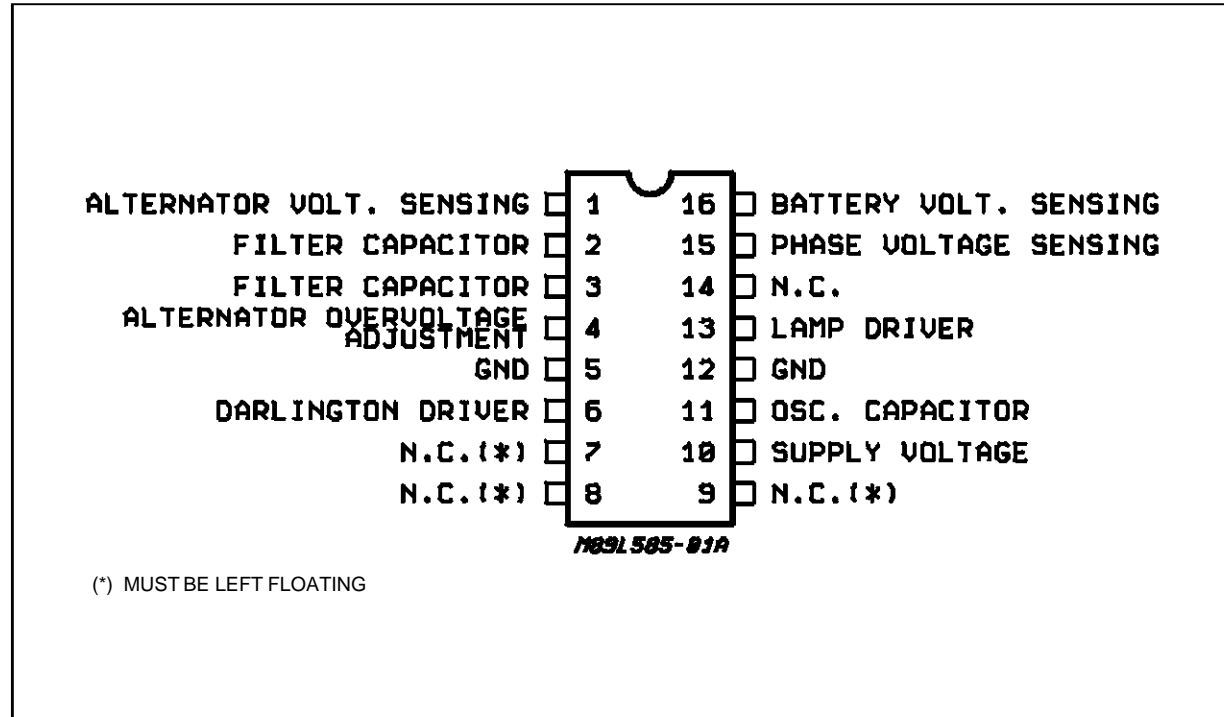

ABSOLUTE MAXIMUM RATINGS

| Symbol | Parameter | Value | Unit |
|-----------|---|-------------|------|
| V_S | Operating supply Voltage (through R_S) | 28 | V |
| V_D | Dump Voltage | 100 | V |
| T_j | Junction Temperature Range | - 40 to 150 | °C |
| P_{tot} | Power Dissipation at $T_{amb} = 80^\circ\text{C}$ | 1 | W |
| T_{stg} | Junction and Storage Temperature Range | - 55 to 150 | °C |
| T_{op} | Operating Temperature Range | - 40 to 125 | °C |

THERMAL DATA

| Symbol | Parameter | Value | Unit |
|------------------------|--|--------|------|
| $R_{th\ j-amb}$ | Thermal Resistance Junction-ambient (*) for DIP 16 | Max 80 | °C/W |
| $R_{th\ j-alumina(*)}$ | Thermal Resistance Junction-alumina for SO-16 | Max 50 | °C/W |

Note : Soldered on PC board that simulates an application with medium device density on board.

(*) Thermal resistance junction-pins with the chip soldered on the middle of an alumina supporting substrate measuring 15 ÷ 20 mm ; 0.65 mm thickness and infinite heatsink.

PIN FUNCTIONS

| N° | Name | Functions |
|-------|-----------------------------------|--|
| 1 | Alternator Voltage Sensing | Connection for voltage regulation sensing. The regulation sensitivity is a function of R1 and is given by : $S = \frac{\Delta VA}{\Delta R1} = 0.5mV/\Omega$ |
| 2-3 | Filter Capacitor | A capacitor connected between these two pins filters the feedback signal from the regulated output. Typically the input impedance is 15K Ω . |
| 4 | Alternator Overvoltage Adjustment | When this pin is left open circuit the overvoltage threshold is as described in the specification. Typically the warning lamp is switched on when the voltage at this pin is greater than 3.5V. This threshold can be modified with a resistor between either the ground or pin 2. |
| 5 | GND | This pin must be connected to ground. |
| 6 | Darlington Driver | This pin drives the external darlington disabling it by shorting the current in R _B to ground. |
| 7-8-9 | N.C. | These pins must be left floating. |
| 10 | IC Supply Voltage | Supply Voltage Input A 7.5V (typical) Zener is present at the input. |
| 11 | Oscillator Capacitor | A capacitor connected to ground sets the frequency of the internal oscillator. The frequency is given by : $f_{osc} = \frac{20 \times 10^{-6}}{8.4 \times C_{osc}}$ |
| 12 | GND | This pin must be connected to ground. |
| 13 | Lamp Driver | Current Driver for External Lamp for Diagnostics. Internally protected against short circuits (current limiting), load dump transients and, by means of a zener, against low energy spikes. |
| 14 | NC | Not connected. |
| 15 | Phase Voltage Sensing. | Connection for no charge sensing from the alternator . The internal low threshold is typically 2.4V. By means of the external divider R3/R4 the threshold can be adjusted to give the required sensitivity. |
| 16 | Battery Voltage Sensing | Connection for Voltage Battery Sensing This pin senses a failure of the alternator-battery lead as the voltage difference V _A -V _S . The external resistor R2 limits the current in overvoltage protection. |

L585

ELECTRICAL CHARACTERISTICS ($V_S = 14.4V$; $-30^{\circ}C \leq T_j \leq 100^{\circ}C$ unless otherwise specified ; refer to application circuit)

| Symbol | Parameter | Test Conditions | Min. | Typ. | Max. | Unit |
|--------|-----------|-----------------|------|------|------|------|
|--------|-----------|-----------------|------|------|------|------|

REGULATION

| | | | | | | |
|--------------|----------------------------------|---|-------------------------|----------|-------------------------|------------------|
| V_S | Operating Supply Voltage | | 6 | | 25 | V |
| I_d | Quiescent Drain Current (pin 10) | $V_{10} = 5.5V$ | | | 24 | mA |
| V_A | Alternator Reg. Voltage | $T_j = 20^{\circ}C, t = 100ms$ $R_1 = 1.3K\Omega$ (1) $T_j = -30^{\circ}C$ $T_j = +100^{\circ}C$ | 14.26 14.60 13.32 | 14.55 | 14.84 15.50 14.17 | V V V |
| ΔV_A | Voltage Reg. Range | $10\% < d < 90\%$ | | ± 60 | | mV |
| S | Sensitivity to R_1 Variation | $S = dV_A/dR_1$ | 0.35 | | 0.65 | mV/ Ω |
| TC_{nS} | Normalized S Temperature Coeff. | $1/S * dS/dT$ | | -2000 | | ppm/ $^{\circ}C$ |
| $V_{6 sat}$ | Darlington Driver Satur. Voltage | $I_6 = 20mA$ | | | 200 | mV |
| f_s | Oscillation Frequency | $C_{osc} = 20nF$ | 80 | | 170 | Hz |
| I_1 | Standby Current (pin 1) | $V_{batt} = 12V$ | | | 2 | mA |

DIAGNOSTIC

| | | | | | | |
|--------------|---|---|----------------------------|--------------|----------------------------|--------|
| V_{AH} | Overcharging Voltage Threshold (2) | $T_j = 25^{\circ}C$ $R_1 = 1.3K\Omega$ $V_S = V_{AH}$ (3) $-30^{\circ}C < T_j < +100^{\circ}C$ | 1.054 V_A 1.049 V_A | | 1.086 V_A 1.091 V_A | V V |
| V_{PL} | Low Level Phase Voltage Threshold (no load) (4) | $f = 600Hz, T_j = 25^{\circ}C$ $-30^{\circ}C < T_j < +100^{\circ}C$ | 5 4.5 | 6 6 | 7 7.5 | V V |
| V_{AS} | Difference Between Altern. and Supply Voltage (5) | $T_j = 25^{\circ}C$ $-30^{\circ}C < T_j < +100^{\circ}C$ | 2.33 2.00 | 3.10 3.31 | 3.88 4.18 | V V |
| $V_{13 sat}$ | Lamp Driver Saturation Voltage | $I_{13} = 250mA$ | | | 1.5 | V |
| $V_{13 off}$ | Lamp Driver Voltage without Power Supply (6) | $R_S > 48\Omega$ | | | 4.5 | V |
| t_d | Alarm Delay | $C_{osc} = 20nF$ | 70 | | 1.50 | s |

- Notes :**
- $d = 50\%$ the duty cycle of the output signal at pin 6.
 - The lamp is switched on with a fixed delay when the alternator voltage becomes higher than V_{AH} . (overcharge indication).
 - Measured 100 ms after turn-on.
 - The lamp is switched on with a fixed delay when the voltage V_p becomes lower than V_{PL} (the alternator is not charging the battery).
 - The lamp is switched on when the cable B is broken ($V_A - V_S$ becomes higher than V_{AS}).
 - The lamp is switched on when the cable A is broken (IC without power voltage supply).
 - When the voltage at pin 1 is greater than $V_{1 dp}$ the internal darlington of the lamp is switched off.

ELECTRICAL CHARACTERISTICS (continued)

| Symbol | Parameter | Test Conditions | Min. | Typ. | Max. | Unit |
|--------|-----------|-----------------|------|------|------|------|
|--------|-----------|-----------------|------|------|------|------|

PROTECTION

| | | | | | | |
|------------|---|---|-----------|----|----------|--------|
| T_{sh} | Darlington Thermal Shutdown Threshold | | 150 | | | °C |
| V_{Zen} | (pin 10) Zener Voltage | $I_o = 60mA$ $I_o = 130mA$ | 6 6.2 | | 8 8.2 | V V |
| V_{1dp} | Overvoltage Protection Threshold (7) | $T_j = 25°C$ $-30°C < T_j < +100°C$ | 25 23 | 32 | 38 40 | V V |
| I_{13sc} | Lamp Driver Circuit Current | | 300 | | 1500 | mA |
| I_{dump} | Pin 13 Dump Sustaining Capability Current | $V_{13} = 110V @ T_j = 25°C$ $V_1 = 50V @ t = 100ms$ | | | 200 | mA |
| V_{Z13} | Zener Clamping Voltage | $I_{13} = 100mA @$ $t < 3ms$ | 110 | | | V |
| | | $I_{13} = 40mA @$ $t < 6ms, full T$ $T_j = -30°C$ | 100 90 | | | V V |

- Notes :**
1. $d = 50\%$ the duty cycle of the output signal at pin 6.
 2. The lamp is switched on with a fixed delay when the alternator voltage becomes higher than V_{AH} . (overcharge indication).
 3. Measured 100 ms after turn-on.
 4. The lamp is switched on with a fixed delay when the voltage V_p becomes lower than V_{PL} (the alternator is not charging the battery).
 5. The lamp is switched on when the cable B is broken ($V_A - V_S$ becomes higher than V_{AS}).
 6. The lamp is switched on when the cable A is broken (IC without power voltage supply).
 7. When the voltage at pin 1 is greater than V_{1dp} the internal darlington of the lamp is switched off.

CIRCUIT OPERATION

The L585 alternator regulator performs two main functions : regulation control and fault diagnostics.

REGULATION

The alternator voltage is compared with a reference voltage in an error amplifier (see block diagram), the output of which determines the duty cycle of the external darlington. This darlington switches the current in the excitation coil of the alternator.

The switching frequency is fixed and is set by the external capacitor C_{OSC} (see application circuit). Ca-

pacitive positive feedback and a monostable eliminates spurious switching caused by contact bounce. The base current delivered to the external darlington is set by the resistor R_B (see application circuit) and must be dimensioned according to the characteristics of this darlington and the maximum coil current.

DIAGNOSTIC

This circuit receives information from the battery, the alternator and one alternator phase. It indicates anomalous conditions by driving a 3 W lamp. To prevent spurious fault warnings some indications are not displayed immediately but are delayed by a fixed time. No external components are needed to implement this delay since it is produced internally by dividing the internal oscillator with an eight-stage divider to give a delay of 128 periods. For a one second delay the oscillator frequency must be 128 Hz.

The lamp is driven after a delay when the following conditions occur : no charge, break or short circuit in the alternator sense wire.

The diagnostic lamp is driven immediately when the cable connecting the alternator to the battery is broken ($V_A - V_{batt}$ above 2.6 typ.) or when the IC is without power supply ($V_{CE sat}$ of the lamp driver is 2.4 V typ. in this case).

PROTECTION

SHORT CIRCUIT PROTECTION

The integrated darlington is protected against short circuits of the lamp. The short circuit current is limited at 600 mA and if this condition persists thermal protection will intervene.

DUMP PROTECTION

The whole IC is protected against load dump transients (100 V, 300 ms with a rise time greater than 5 ms) in the typical application circuit. The only component to which this transient is directly applied (no

series resistances) is the lamp driver darlington. During transients the darlington is kept off and can withstand peak voltages of 100 V. Additionally, the IC can withstand low energy spikes up to 300 V. These spikes are clamped by an internal 100 V zener on the collector of the lamp driver darlington.

THERMAL PROTECTION

When the IC temperature reaches 170 °C the lamp driver darlington is kept off.

Figure 1 : Application Circuit.

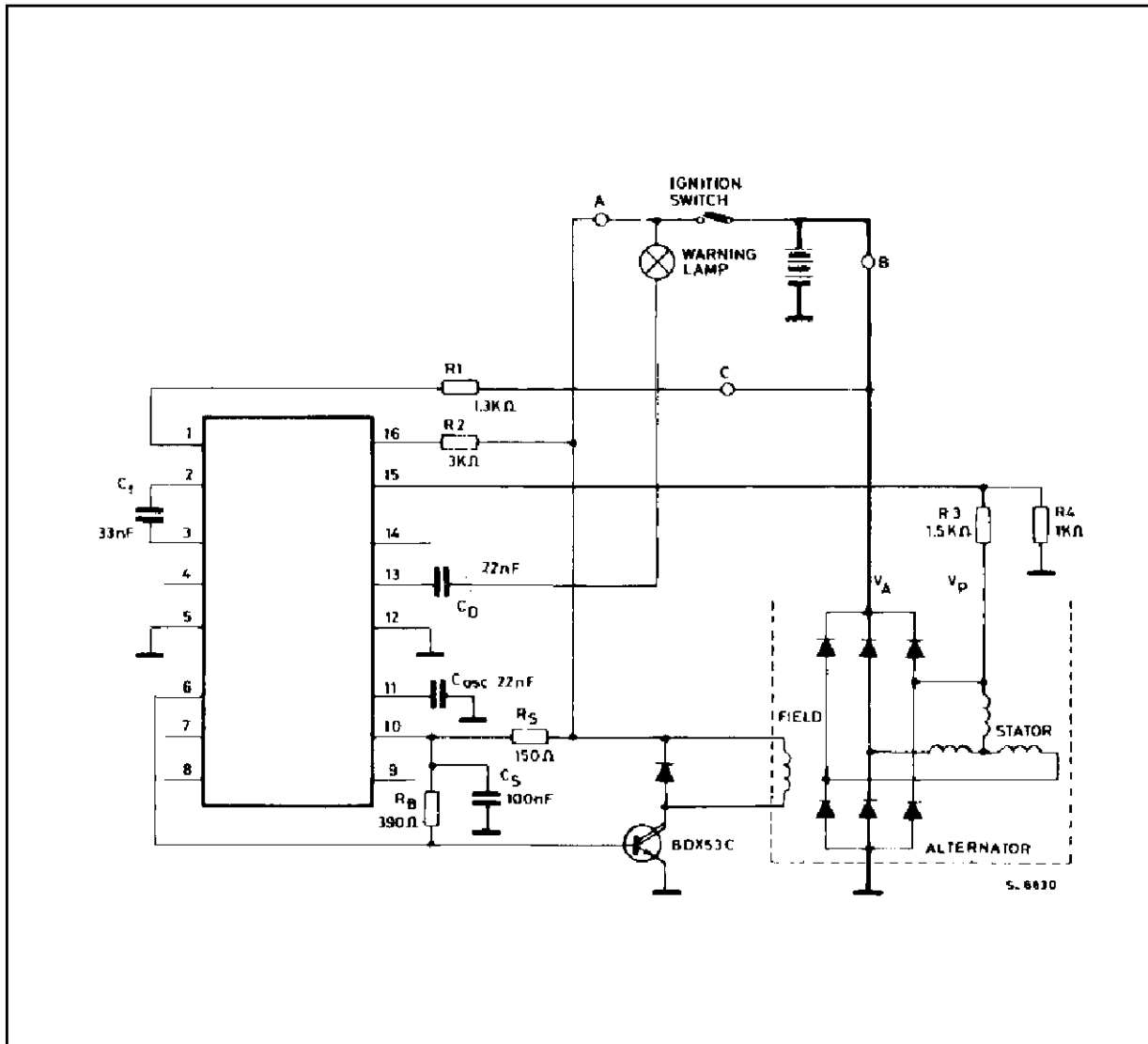

The device is able to withstand all the voltage transients mentioned in ISO DP7637/1. If voltage transients more severe than the above ISO standard have to be withstood, an external protection device

(transil) must be connected between pin 15 and GND. For transients up to 250V, $t_{pulse} = 500\mu s$, $R_{source} = 47\Omega$, the transil P6KE100P is recommended.

DIP16 PACKAGE MECHANICAL DATA

| DIM. | mm | | | inch | | |
|------|------|-------|------|-------|------|-------|
| | MIN. | TYP. | MAX. | MIN. | TYP. | MAX. |
| a1 | 0.51 | | | 0.020 | | |
| B | 0.77 | | 1.65 | 0.030 | | 0.065 |
| b | | 0.5 | | 0.020 | | |
| b1 | | 0.25 | | 0.010 | | |
| D | | | 20 | | | 0.787 |
| E | | 8.5 | | 0.335 | | |
| e | | 2.54 | | 0.100 | | |
| e3 | | 17.78 | | 0.700 | | |
| F | | | 7.1 | | | 0.280 |
| I | | | 5.1 | | | 0.201 |
| L | | 3.3 | | 0.130 | | |
| Z | | | 1.27 | | | 0.050 |

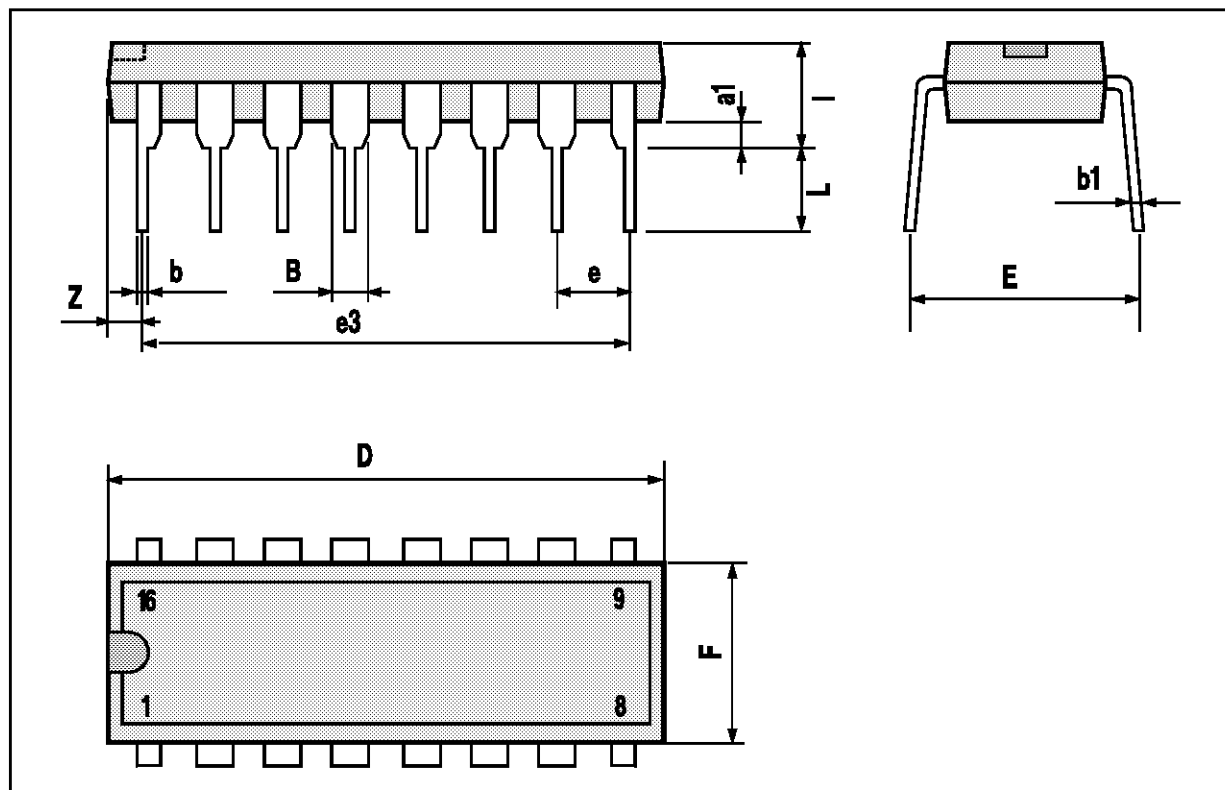

L585

SO16 PACKAGE MECHANICAL DATA

| DIM. | mm | | | inch | | |
|------|------------|------|------|-------|-------|-------|
| | MIN. | TYP. | MAX. | MIN. | TYP. | MAX. |
| A | | | 1.75 | | | 0.069 |
| a1 | 0.1 | | 0.2 | 0.004 | | 0.008 |
| a2 | | | 1.6 | | | 0.063 |
| b | 0.35 | | 0.46 | 0.014 | | 0.018 |
| b1 | 0.19 | | 0.25 | 0.007 | | 0.010 |
| C | | 0.5 | | | 0.020 | |
| c1 | 45° (typ.) | | | | | |
| D | 9.8 | | 10 | 0.386 | | 0.394 |
| E | 5.8 | | 6.2 | 0.228 | | 0.244 |
| e | | 1.27 | | | 0.050 | |
| e3 | | 8.89 | | | 0.350 | |
| F | 3.8 | | 4.0 | 0.150 | | 0.157 |
| L | 0.5 | | 1.27 | 0.020 | | 0.050 |
| M | | | 0.62 | | | 0.024 |
| S | 8° (max.) | | | | | |

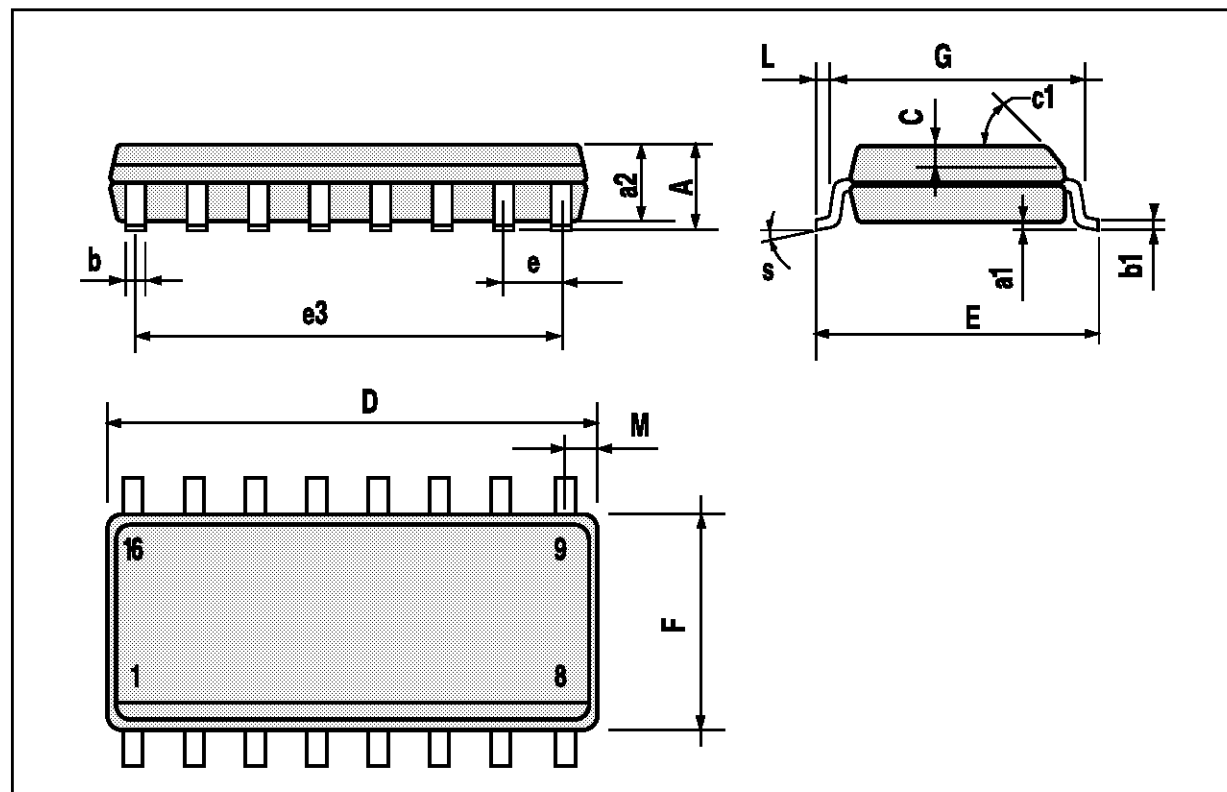

Information furnished is believed to be accurate and reliable. However, SGS-THOMSON Microelectronics assumes no responsibility for the consequences of use of such information nor for any infringement of patents or other rights of third parties which may result from its use. No license is granted by implication or otherwise under any patent or patent rights of SGS-THOMSON Microelectronics. Specifications mentioned in this publication are subject to change without notice. This publication supersedes and replaces all information previously supplied. SGS-THOMSON Microelectronics products are not authorized for use as critical components in life support devices or systems without express written approval of SGS-THOMSON Microelectronics.

© 1994 SGS-THOMSON Microelectronics - All Rights Reserved

SGS-THOMSON Microelectronics GROUP OF COMPANIES

Australia - Brazil - France - Germany - Hong Kong - Italy - Japan - Korea - Malaysia - Malta - Morocco - The Netherlands - Singapore - Spain - Sweden - Switzerland - Taiwan - Thailand - United Kingdom - U.S.A.