

3 CHANNELS MULTIPOWER SYSTEM

ADVANCE DATA

- CHANNEL-A AND CHANNEL-B FOR UNIPO-LAR STEPPER MOTORS
 - LOW SIDE: $R_{DS(ON)} = 1.2\Omega$
 - HIGH SIDE ; $R_{DS(ON)} = 1.2\Omega$
- CHANNEL-C FOR DC MOTORS
 - LOW SIDE: $R_{DS(ON)} = 1.7\Omega$
 - HIGH SIDE: $R_{DS(ON)} = 1.2\Omega$
- CHOPPING MODE DRIVING FOR C.L. CUR-RENT CONTROL ON CHA AND CHB AND O.L. VOLTAGE CONTROL ON CHC.
- INTERNAL FOUR DRIVING LATCHES
- 16 BIT INTERNAL SHIFT REGISTER
- DIRECT INTERFACE TO μP
- SERIAL DRIVING SEQUENCE LOADING
- CMOS COMPATIBLE INPUTS
- PRE-ALARM OUTPUT SIGNAL
- THERMAL SHUTDOWN

MULTIPOWER BCD TECHNOLOGY

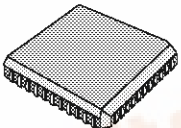

PLCC44
L6285

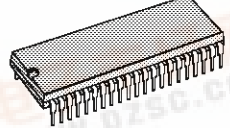

SDIP42
L6285S

ORDERING NUMBERS:

DESCRIPTION

This Combo Motor Driver uses large scale integration to incorporate several functions into the same chip.

- 1) Two unipolar stepper motor driver
- 2) A full bridge DC motor driver

3) Serial microprocessor interface

The power output stages are DMOS and the input can be interfaced to a CMOS Microprocessor logic.

The phase current in the unipolar stepper motor windings is controlled by two external sensing resistors in fixed frequency chopping mode. The oscillator block provides clocks each other 180° out of phase to the two stepper motor driver in order to avoid symultaneous current peaks.

For the DC motor driver is used a bridge; the RMS voltage to supply this motor is fixed by a

BLOCK DIAGRAM

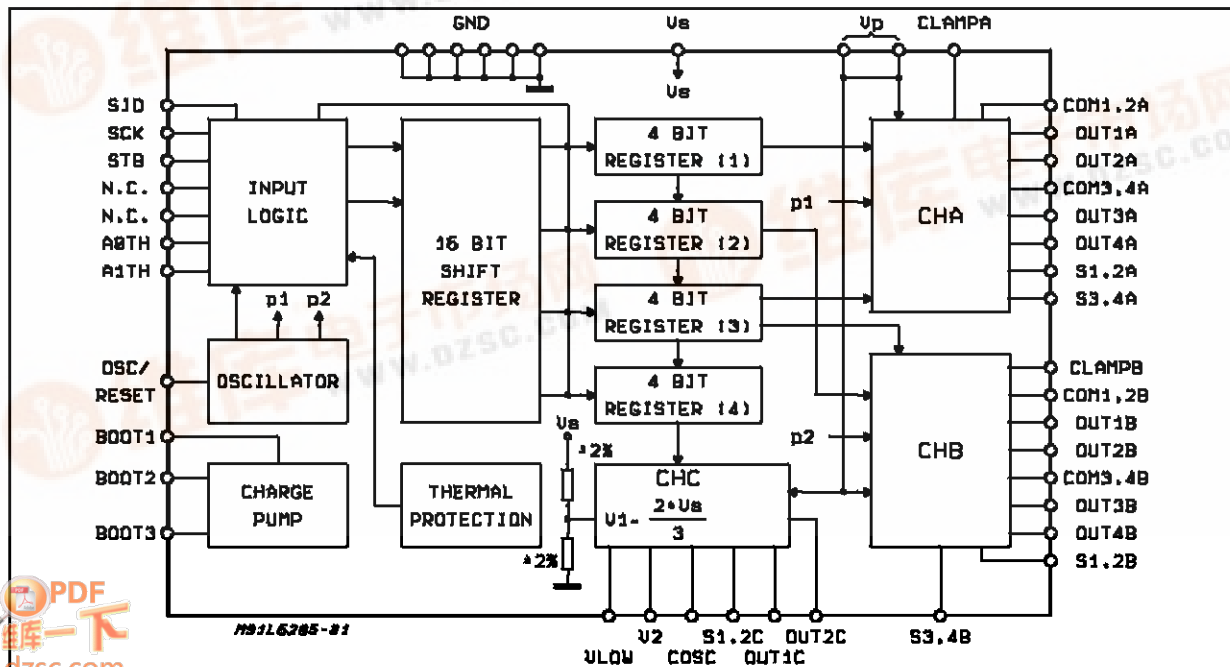

L6285

simple PWM open loop. The 3 motors are controlled by the micro through 4 latches of 4 bit each. The loading of these registers is in serial mode. The I.C. operates at 5V supply for the logic and at

24V supply for the power stages. The packages are SDIP42 and PLCC44 with 6 pins devoted to ground and to sink out the heat produced by power dissipation.

PIN CONNECTION (Top view)

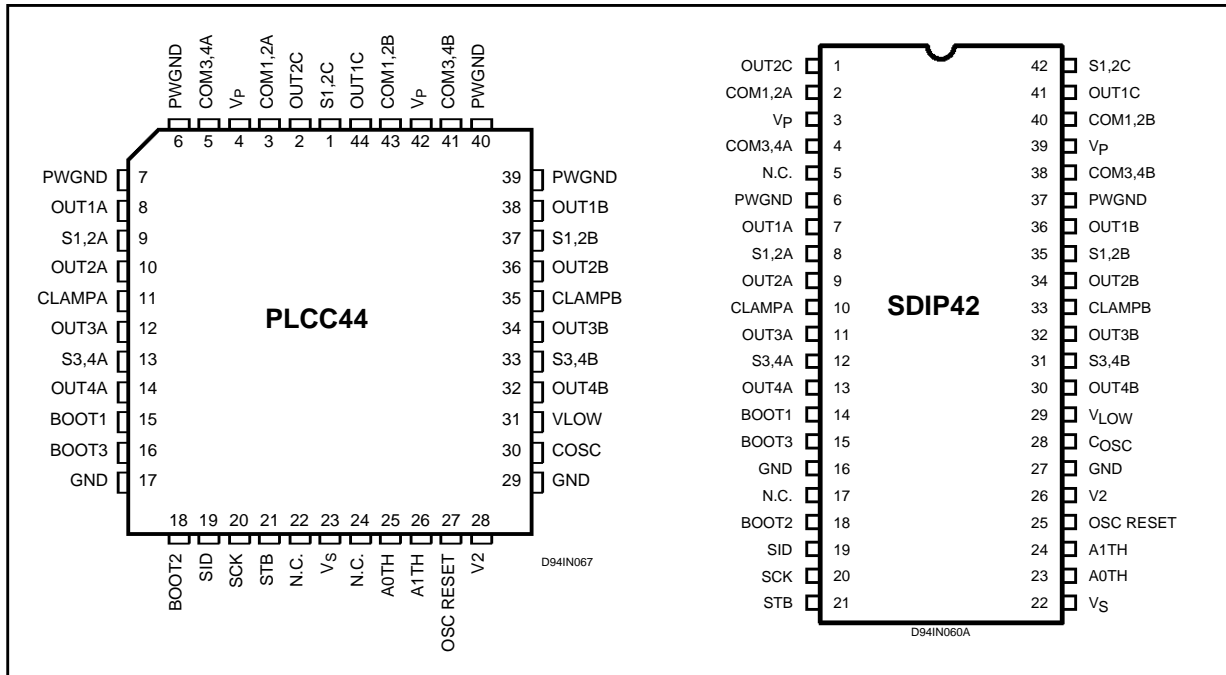

ABSOLUTE MAXIMUM RATINGS

Symbol	Parameter	Value	Unit
V_P	Power Supply Voltage	30	V
V_S	Logic Supply Voltage	7	V
V_{in}	Logic Input Voltage	-0.3 to $V_S + 0.3$	V
I_{LOW}	Low Side DMOS max DC Current	1	A
I_{HIGH}	High Side DMOS max DC Current	1	A
I_{pLOW}	Low Side DMOS max Peak Current (1 μ s On; 50 μ s OFF)	2	A
I_{pHIGH}	High Side DMOS max Peak Current (1 μ s On; 50 μ s OFF)	2	A
V_{bout}	Max Output Voltage of Stepper Motor Driver (transient rcirculation)	60	V
$V_{sense 1;2}$	Max Voltage ON Vsense (CHA/CHB)	-1 to 2	V
$V_{sense 3}$	Max Voltage ON Vsense (CHC)	-1 to 2	V
I_{fdDC}	Max DC Current of Forward Diode (DMOS Source Drain Diode)	1	A
I_{fdpk}	Max Peak Current of Forward Diode (DMOS Source Drain Diode) (1 μ s On; 50 μ s OFF)	2	A
P_{tot}	Total Power Dissipation ($T_{pins} = 90^\circ\text{C}$) With minimized dissipating copper area ($T_{amb} = 70^\circ\text{C}$)	5 1.6	W W
T_{op}	Operating Temperature Range	0 to 150	$^\circ\text{C}$
T_{stg}	Storage Temperature Range	-40 to 150	$^\circ\text{C}$

THERMAL DATA (PLCC44)

Symbol	Description		SDIP42	PLCC44	Unit
$R_{th j-pins}$	Thermal Resistance Junction-pins	Max.	15	12	$^\circ\text{C}/\text{W}$
$R_{th j-amb}$	Thermal Resistance Junction-ambient	Max.	48	50	$^\circ\text{C}/\text{W}$

PIN DESCRIPTION

SDIP42 N°	PLCC44 N°	Name	Functions
42	1	S1,2C	Full bridge common source output to separate between power GND and logic GND.
1,41	2,44	OUT 1C, OUT 2C	Output of the channel C bridge.
2	3	COM 1,2A	High side DMOS channel A for current chopping in the windings connected pins to OUT 1A, OUT 2A.
3,39	4,42	V _p	Power Supply Voltage.
4	5	COM 3,4A	High side DMOS channel A for current chopping in the windings connected to pins OUT 3A, OUT 4A.
6,37	6,7,39,40	GND	PowerGround and heatsink pins.
7,9,11,14	8,10,12,14	OUT 1A, OUT 2A OUT 3A, OUT 4A	Low side DMOS outputs of channel A stepper motor driver.
8	9	S1,2A	Channel A sources of the DMOS OUT 1A, OUT 2A. A sensing resistor has to be connected from this pin and ground, for current control of phase 1,2 A.
10,33	11,35	CLAMP A, CLAMP B	These pins have to be connected to an external zener diode to clamp the output voltage spikes of channel A/B.
12	13	S3,4A	Channel A sources of the DMOS OUT 3A, OUT 4A. A sensing resistor has to be connected from this pin and ground, for current control of phase 3,4 A.
14	15	BOOT 1	A capacitor between this pin and V _p stores the overvoltage for each high side DMOS driver gate.
15	16	BOOT 3	A capacitor between this pin and internal diodes allows the charge pump to transfer energy to the capacitor at the pin BOOT 1.
16,27	17,29	GND	Logic Ground and Heatsink pins.
18	18	BOOT 2	Charge pump oscillator output.
19	19	SID	Serial data input.
20	20	SCK	Serial clock for serial data input.
21	21	STB	Strobe to transfer the 16 bit shift register contents to the latch registers.
5,17	22,24	NC	Not connected.
22,39	23	V _s	Logic Supply Voltage.
23,24	25,26	A0TH / A1TH	Open collector outputs for thermal informations to the μ P.
25	27	OSC/ RESET	An RC network connected to this pin defines the oscillator frequency for stepper drivers. When OSC/RES is <1V, a reset signal is internally generated.
26	28	V2	A voltage to this pin defines the output duty cycle of Channel C.
28	30	C _{osc}	A capacitor connected to this pin defines the chopping frequency of channel C.
29	31	V _{low}	This pin is low when the chopping low voltage (V2 low level) is selected; it is in high impedance when the chopping high voltage (V2 high level) is selected. Only for CHC operation.
30,32,34,36	32,34,36,38	OUT4B, OUT3B OUT2B, OUT1B	Low side DMOS outputs of channel B stepper motor driver.
31	33	S 3, 4B	Same as S 3, 4A, but for channel B.
35	37	S 1, 2B	Same as S 1, 2A, but for channel B.
38	41	COM 3, 4B	Same as COM 3, 4A, but for channel B.
40	43	COM 1, 2B	Same as COM 1, 2A, but for channel B.

L6285**ELECTRICAL CHARACTERISTICS** ($T_j = 25\text{ }^\circ\text{C}$, $V_s = 5\text{V}$, $V_p = 24\text{V}$ unless otherwise specified)

Symbol	Parameter	Test Conditions	Min.	Typ.	Max.	Unit
V_p	Power Supply Voltage		9		26.5	V
I_p	Quiescent Power Supply Current	(note 1)			7	mA
V_s	Logic Supply Voltage		4.5		5.5	V
I_s	Quiescent Logic Supply Current	(note 1)			20	mA

LOGIC LEVEL

Symbol	Parameter	Test Conditions	Min.	Typ.	Max.	Unit
V_{inL}	Input Low Voltage		-0.3		1.35	V
V_{inH}	Input High Voltage		3.15		$V_s+0.3$	V
I_{inL}	Input Low Current	$V_{in} = V_{inL}$	-10			μA
I_{inH}	Input High Current	$V_{in} = V_{inH}$			10	μA

CHANNEL A AND CHANNEL B (UNIPOLAR MOTORS)

Symbol	Parameter	Test Conditions	Min.	Typ.	Max.	Unit
R_{DSONL}	Low Side DMOS ON Res.	$I_{DS} = 0.7\text{A}$			1.2	Ω
R_{DSONH}	High Side DMOS ON Res.	$I_{DS} = 0.7\text{A}$			1.2	Ω
I_{DSSL}	Low Side DMOS Leakage Current	$V_{DS} = 60\text{V}$; output OFF			2	mA
I_{DSSH}	High Side DMOS Leakage Current	$V_P = 30\text{V}$; $V_O = 0\text{V}$	-1.5			mA
V_{REF}	Voltage reference to the Comparator	LEVEL 1 LEVEL 2 LEVEL 3 LEVEL 4	100 220 340 465	125 250 375 500	150 280 410 535	mV mV mV mV
T_d	Turn OFF Delay on HIGH Side DMOS after the Sensing Current Reach the Threshold Value	(note 2)			1	μs
f_{max}	Max Chopping Frequency				40	KHz

CHANNEL C (DC MOTORS) (see Fig. 5)

Symbol	Parameter	Test Conditions	Min.	Typ.	Max.	Unit
f_{osc}	Oscillator Frequency	$C_{osc} = 3.3\text{nF}$; $V_1 = 2/3V_s$	17	22	28	KHz
DC	Duty Cycle	$V_2 = 1/2V_s$	72	75	81	%
I_{b2}	Comparator Input Bias	$V_2 = 200\text{mV}$	-1			μA
V_{low}	Open Drain Output	$I = 5\text{mA}$		0.2	0.4	V
R_{DSONH}	High Side DMOS ON Res.	$I_{DS} = 0.7\text{A}$			1.2	Ω
R_{DSONL}	Low Side DMOS ON Res.	$I_{DS} = 0.7\text{A}$			1.7	Ω
I_{LH}	HSD MOS Leakage Current	$V_P = 30\text{V}$; $V_O = 0\text{V}$	-1			mA
I_{LL}	LSD MOS Leakage Current	$V_O = 30\text{V}$; $V_{sense} = 0\text{V}$	-1.5			mA
V_{fddc}	Forward Diode DC Voltage (DMOS Diode)	$I_{fddc} = 0.7\text{A}$		1.4	2	V
f_{max}	Max Chopping Frequency				40	KHz
V_{boot}	Voltage on pin Boot1		$V_p + 7$			V
I_{Lboot}	Leakage Current on pin Boot1	$V_{bott} = V_p + 12\text{V}$; $V_p = 26.5\text{V}$			200	μA

ELECTRICAL CHARACTERISTICS (continued)

OSCILLATOR (see Fig. 6)

Symbol	Parameter	Test Conditions	Min.	Typ.	Max.	Unit
f_{osc}	Oscillator Frequency Pin OSC/RESET	$C_{osc} = 3.3nF$; $R_{osc} = 10K\Omega$	27	41	46	KHz
T_{dsc}	Capacitor Discharge Time (protect dead time)	$C_{osc} = 3.3nF$; $R_{osc} = 10K\Omega$ (see Fig. 1)	0.8	1.4	2	μs
V_{reset}	Reset Threshold Voltage		1			V

INTERFACE TIMING

Symbol	Parameter	Test Conditions	Min.	Typ.	Max.	Unit
t_1	SCK Data Clock Cycle	(see Fig. 2)	200			ns
t_2	SCK Data Set-upTime		30			ns
t_3	SCK Data Hold Time		20			ns
t_4	SCK-STB Interval Time		30			ns
t_5	STB Pulse Width		100			ns

Note 1: No output loaded; all register to low condition; no reset applied; $V_P = 26.5V$; $V_S = 5.5V$
Note 2: The effect of the internal filter (RC Network) is not considered.

Figure 1: Discharge time t_{dsc} or Protection Time

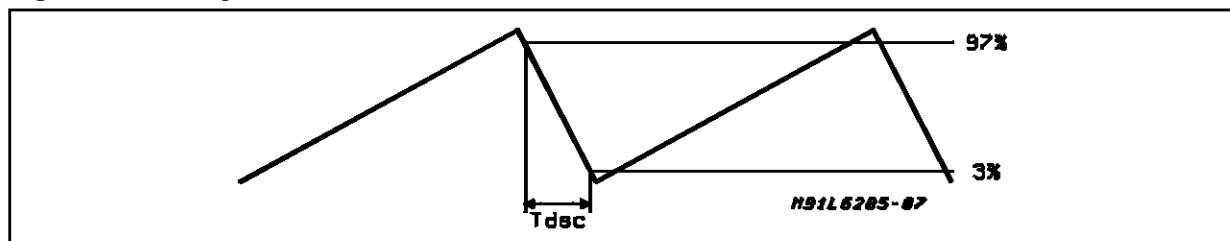
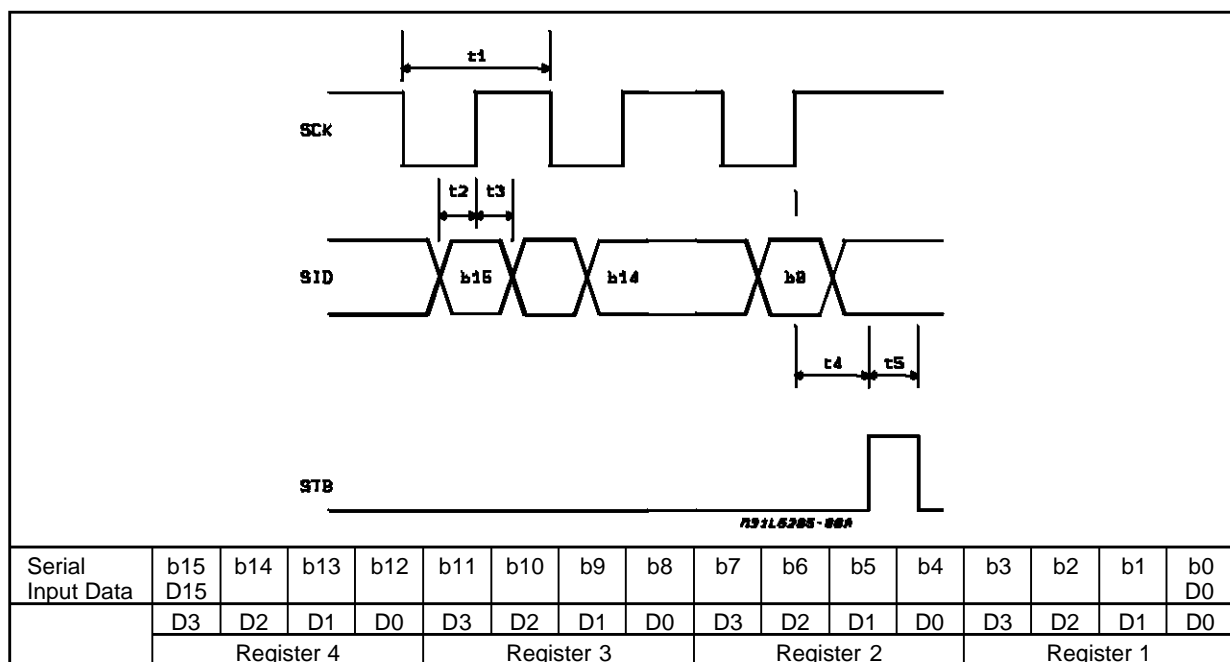

Figure 2: Interface Timing (Serial loading Mode)



L6285

BLOCK DIAGRAM DESCRIPTION

(see Block Diagram)

Inside the I.C. there are two unipolar stepper motor drivers, one bridge driver for DC motor, 4x4 bit latch registers, one shift register, the input logic, the charge pump, and the thermal protection.

The following conditions are valid for all the 3 driver sections:

- 1) When the osc/res pin is tied to GND, an internal reset signal is generated which switches off all the outputs and resets the internal registers.
- 2) The conditions 1 is valid also during power on and power off transitions.
- 3) During power on and power off, the I.C. is safe for any conditions of V_S and V_P

3) If V_P is present and V_S disappears, the outputs are switched off.

Input Logic

The input CMOS logic interfaces the microprocessor logic to the 4 registers. An integrated Schmitt-trigger circuit is used to improve noise immunity at each logic input.

The data is introduced in the 16bit shift register by the SID pin. The first bit b 15 after 16 clock applied to SCK pin will be the D15 of the shift register.

On the falling edge of STB the 16 bits of the shift register are transferred to the outputs of the 4 latch registers. Fig 2 shows the timing.

CHA and CHB Stepper Motor Drivers

Registers

The Combo Motor Driver controls the 3 channels using 4 latch registers of 4 bit each:

REGISTER 1	D0	=	PHASE 1A	CHANNEL A
	D1	=	NPHASE 2A	CHANNEL A
	D2	=	PHASE 3A	CHANNEL A
	D3	=	NPHASE 4A	CHANNEL A
REGISTER 2	D0	=	PHASE 1B	CHANNEL B
	D1	=	NPHASE2B	CHANNEL B
	D2	=	PHASE 3B	CHANNEL B
	D3	=	NPHASE4B	CHANNEL B
REGISTER 3	D0	=	D/A CHANNEL A	LEAST
	D1	=	D/A CHANNEL A	MOST
	D2	=	D/A CHANNEL B	LEAST
	D3	=	D/A CHANNEL B	MOST
REGISTER 4	D0	=	INPUT 1	CHANNEL C
	D1	=	INPUT 2	CHANNEL C
	D2	=	V2 VOLTAGE	CHANNEL C
	D3	=	V2 VOLTAGE	CHANNEL C

Register 1/2 Output Status (CHA and CHB) . See note 1

D0	D1	D2	D3	OUT1 A/B	OUT2 A/B	OUT3 A/B	OUT4 A/B
0	0	0	0	OFF	OFF	OFF	OFF
1	0	0	0	ON	OFF	OFF	OFF
1	0	1	0	ON	OFF	ON	OFF
0	0	1	0	OFF	OFF	ON	OFF
0	1	1	0	OFF	ON	ON	OFF
0	1	0	0	OFF	ON	OFF	OFF
0	1	0	1	OFF	ON	OFF	ON
0	0	0	1	OFF	OFF	OFF	ON
1	0	0	1	ON	OFF	OFF	ON
ALL THE OTHERS				OFF	OFF	OFF	OFF

Register 3 Current Reference (D/A OUTPUT)

DO	D1	REFER. VOLTAGE CHANNEL A
0	0	0.125 V
0	1	0.250 V
1	0	0.375 V
1	1	0.500 V

D2	D3	REFER. VOLTAGE CHANNEL B
0	0	0.125 V
0	1	0.250 V
1	0	0.375 V
1	1	0.500 V

REGISTER 4 (CHC). See note 2

D0	D1	D2	D3	OUT1 C	OUT2 C
X	X	0	0	OFF	OFF
0	0	1	1	OFF	OFF
1	0	1	1	V _P	GND
0	1	1	1	GND	V _P
1	1	1	1	GND	GND
1	0	1	0	V _P	CHOPPING; V2 LOW LEVEL
0	1	1	0	CHOPPING; V2 LOW LEVEL	V _P
1	0	0	1	V _P	CHOPPING; V2 HIGH LEVEL
0	1	0	1	CHOPPING; V2 HIGH LEVEL	V _P
0	0	1	0	OFF	OFF
1	1	1	0	V _P	V _P
0	0	0	1	OFF	OFF
1	1	0	1	V _P	V _P

Note 1: Low side DMOS status (DM1/2 in Fig. 4)

Note 2: Bridge status (see Fig. 3): OFF = tristate; V_P =, DM3/4ON; GND = DM1/2 ON

Figure 3: CHC Chopping Characteristics

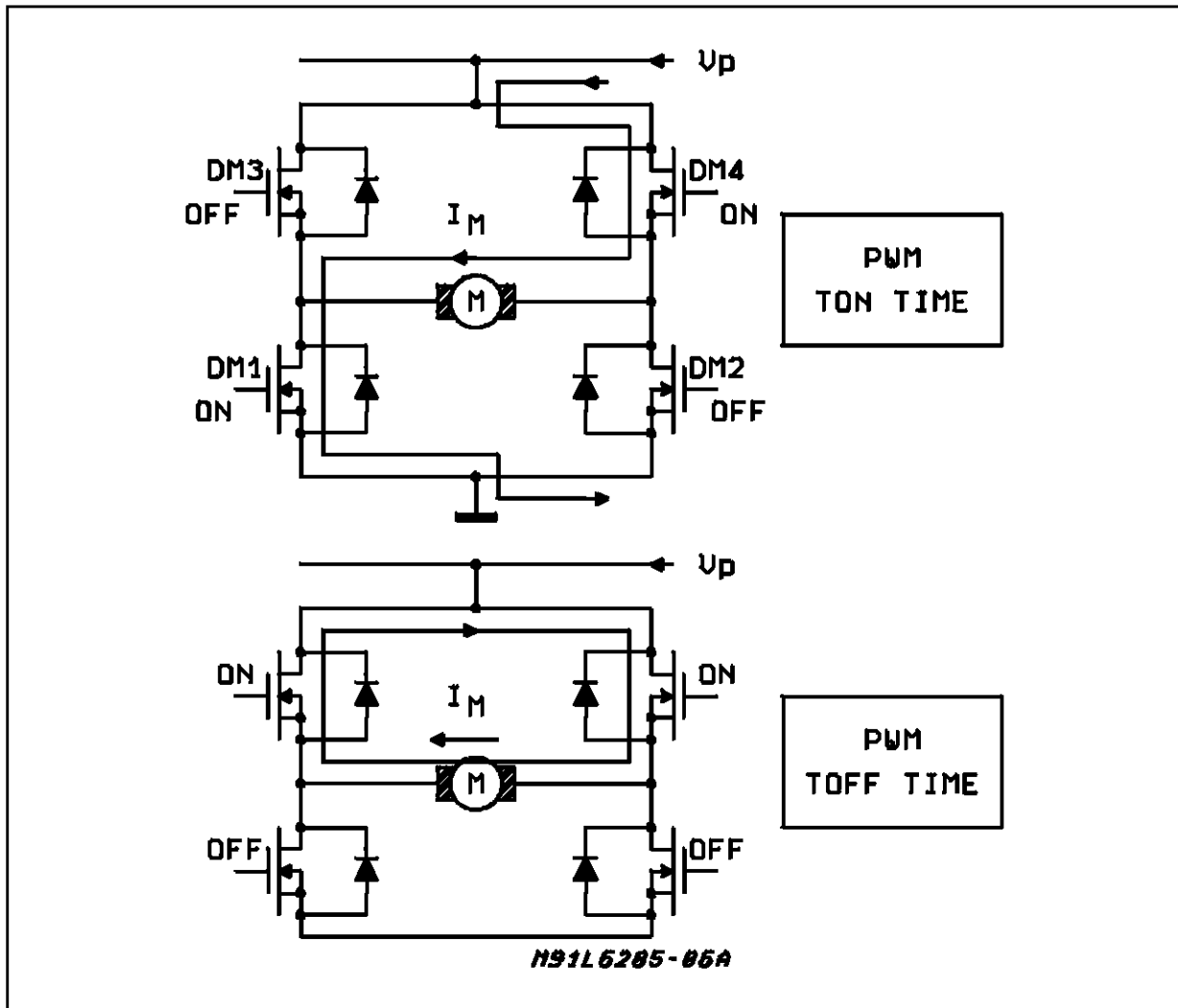

L6285

These two channels drive two unipolar stepper motors in chopping mode. The basic channel configuration is shown in Fig 4. by considering well known the PWM Current Control Loop behaviour here below only particular trick are underlined. During DM3 off period the low side DMOS DM1 and DM2 are switched on to reduce the power dissipation.

The drain overvoltages generated because of the stray inductance of the motor windings are limited by connecting the DZ1 external zener diode to the clamp pin.. The diodes CL1 and CL2 are integrated as far as the CL3 diode which limits the negative voltage at pin COM1.2. An internal RC network ($1\mu\text{s}$) is realized to filter the sensing resistor signal.

Figure.4: Unipolar motor driver CHA (or CHB)

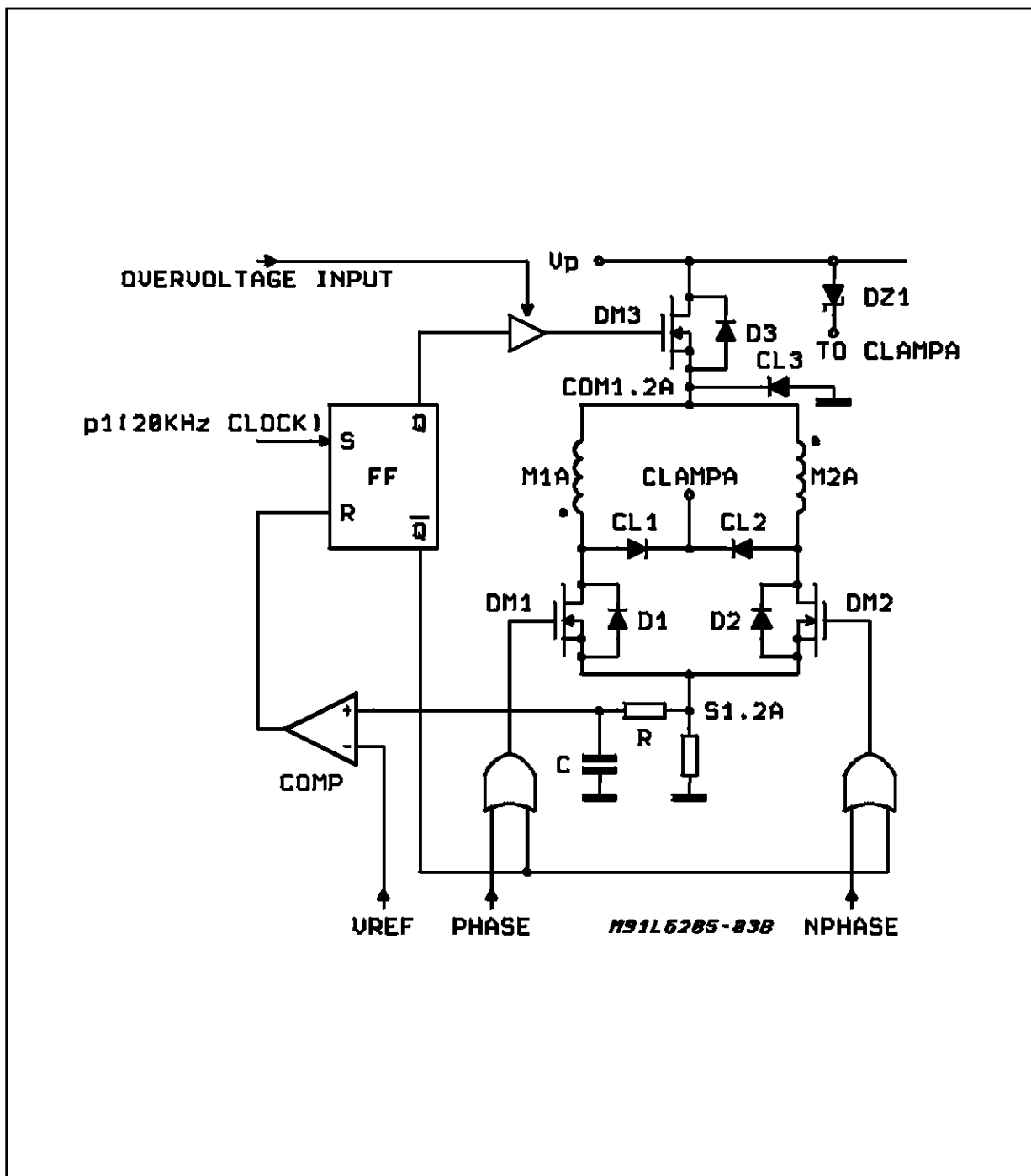

CHC DC Motor Driver

The DC motor driver is a DMOS full bridge with a PWM Open Loop Voltage Control. Fig.5 shows the theory of operation. The C_{osc} Capacitor is charged by a constant current source. The oscillating voltage value is from 0V to the V_1 level internally fixed at $V_1 = 2/3 V_s$. The output duty cycle

is controlled by the V_2 voltage. The operational range of V_2 is from 200mV to V_1 . Fig.3 shows the DMOS status during PWM: t_{ON} and t_{OFF} bridge configurations. While the PWM Duty Cycle defines the motor speed (not controlled since the loop is open), the logic level of IN_1 and IN_2 can choose the direction of the motor.

Figure.5: DC Motor Driver CHC

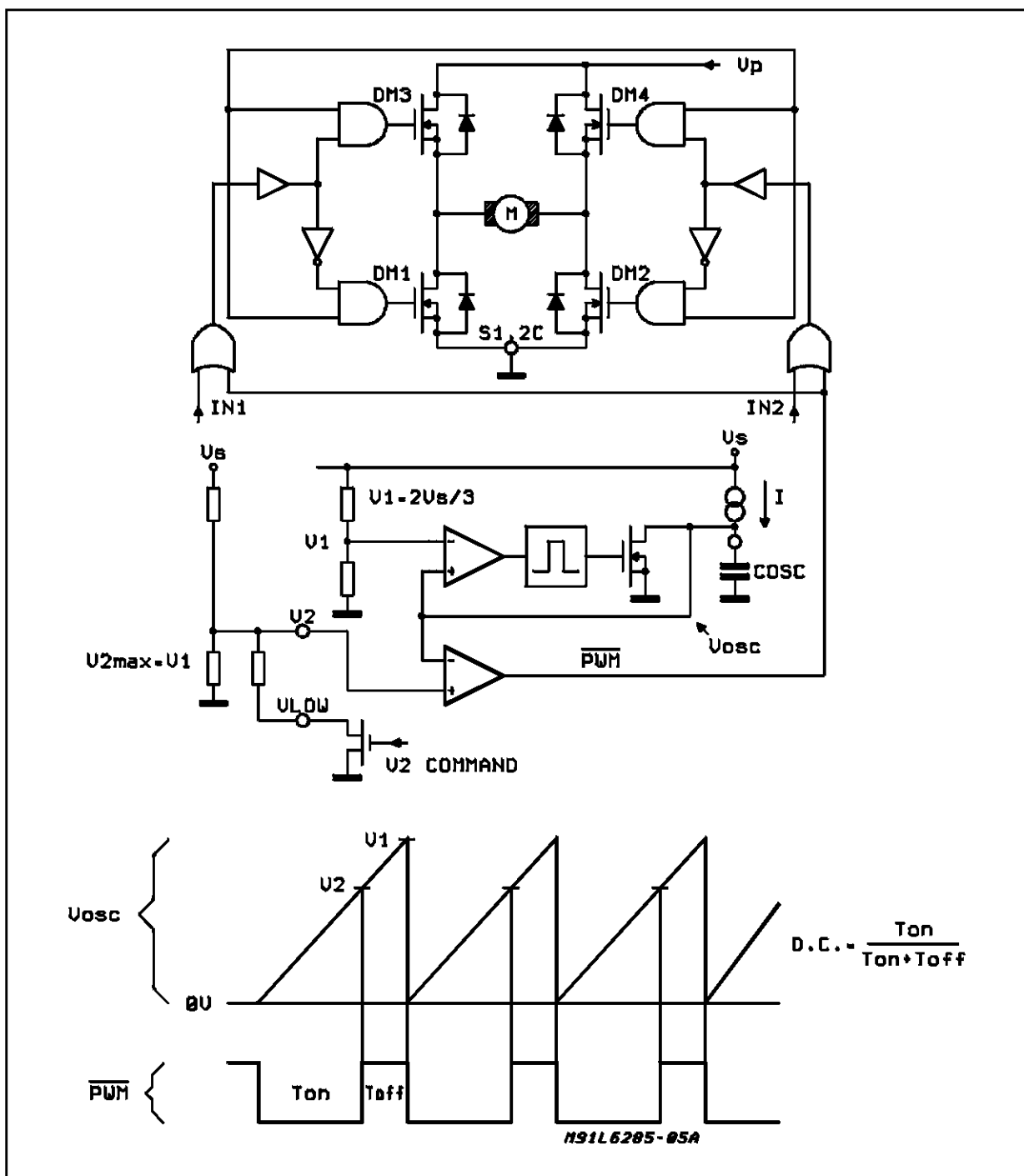

Oscillator For Clock and Reset Generation

The oscillator block provides for two functions:

- 1) Generate an internal reset signal when the voltage at pin osc/res is below 1V. The reset signal switches off all the outputs and resets the logic registers.
- 2) Generate, when the pin osc/res is left free two syncro signals p1 and p2 for the clock of the PWM Current Control of the two stepper driver blocks

The oscillator operates like the 555 concept in

which the capacitor voltage oscillates between $1/3V_s$ $2/3V_s$ (Fig. 6). The oscillator frequency is 2 times the chopping frequency in order to generate the two syncro signals at operative 20KHz PWM. The t_{CH} = charge time of C_{osc} is defined by R_{osc} , V_{TH1} and V_{TH2} (threshold voltages)and C_{osc} .

The discharge time T_{dsc} is practically only defined by C_{osc} and the internal discharge resistor R_{dsc} . The t_{dsc} is also the time lockout during which the RS FF cannot read the Comparator output (see Fig. 4)

Figure 6: Oscillator Concept

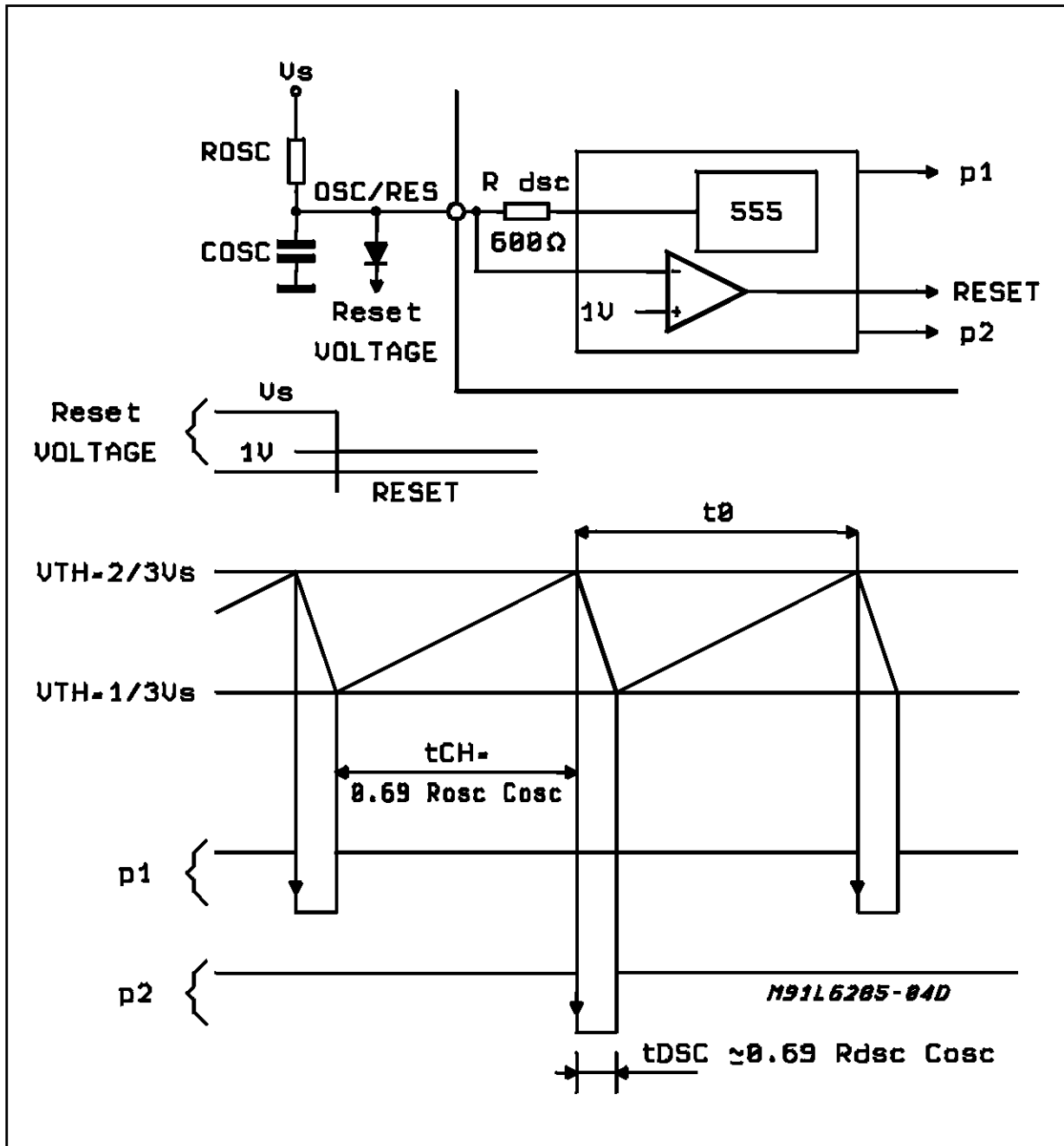

Charge Pump

The charge pump circuitry generates the overvoltage needed to drive the gate of the high side output DMOS power transistors. It is realized by using two external capacitors (C1 and C2) and two integrated diodes that operate as a full wave rectifier

(see Fig. 7). The oscillator peak to peak output voltage is stored by C2 and summed to the Power Supply Voltage V_p . The voltage present at the pin BOOT1, is then the overvoltage needed to supply the gate of the high side DMOS drivers.

Figure 7: Charge Pump Circuit

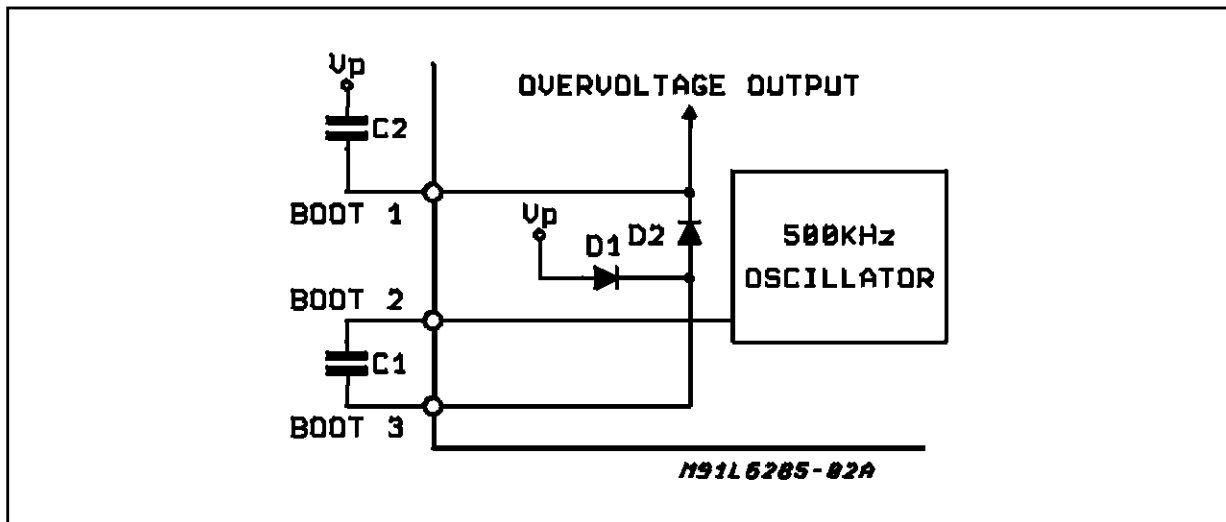

THERMAL PROTECTION

The thermal protection shuts down the chip before it can reach a dangerous temperature.

Additional informations to the microprocessor are available at the A0TH, A1TH pins.

A0TH	A1TH	THERMAL PROTECTION	CIRCUIT STATUS
0	0	OK	OPERATING
1	0	PREALARM	OPERATING
1	1	ALARM	THERMAL SHUTDOWN
0	1	NOT POSSIBLE	

APPLICATION INFORMATION

A typical application circuit is shown in Fig.8. By this application it is possible to drive two unipolar stepper motors (M1,M2) and one DC motor (M3). As it can be seen, only two external Zener diodes (D1,D2) are needed to clamp the voltage transients generated by the stray inductance of the motor windings. This is recommended when the peak current is not more than three to four hundred mAmps. For a power supply voltage of $V_p=24V \pm 10\%$, D1=D2 must be $30V \pm 5\%-1W$ (1N4751A or equivalent). Both the V_p and the V_s pins need bypass capacitors (C1,C2,C3); to supply the high-side DMOS (Source Transistors) at pin.15, only two external capacitors (C4,C5) complete the charge pump circuitry. The oscillator frequency, that is twice the chopping frequency for M1 and M2, is mainly defined by the network R6C6:

$$f_{osc} = [0.69 (R_{ch} + R_{dsc}) C_{osc}]^{-1}, \text{ where } R_{ch} = R6 ; \quad R_{dsc} = 600 \text{ ohm typ.}$$

At the same time, the lockout duration (or protection window) needed for a correct chopping behavior, is given by :

$$T_{lockout} = 0.69 R_{dsc} C_{osc}$$

The shown values (fig.8) give a nominal frequency a little bit more than 41KHz and a protection window of $1.4 \mu s$ roughly. The Schottky diode D3 and the pull-up resistor R5 driven via an open-collector transistor can generate the Reset function. The chopping current is sensed across R1 A/B; R2 A/B that must be of a not inductive type. The DC motor PWM Open Loop Voltage Control operates at a frequency defined by C7, charged with a typical constant current source ($I = 240 \mu A$), up to $V1 = 0.67 V_s$. Since the discharge time is very short, it can be written :

$$f_{osc} = I / C_{osc} V1, \text{ where } C_{osc} = C7.$$

The values indicated in figure give a typical frequency of about 22 KHz.

THERMAL CHARACTERISTICS

The cooling of the device is obtained by soldering its ground pins on a proper p.c.b copper side, acting as a true heatsink. By considering four squared side as in Fig.10, the junction to ambient

thermal resistance has been measured (see Fig.11). The typical transient thermal resistance versus values of single pulse width of power is shown in Fig.12. In general these thermal characteristics are very important to the designer to optimize the L6285 applications.

Figure 10: Four "on board" Square Heatsink

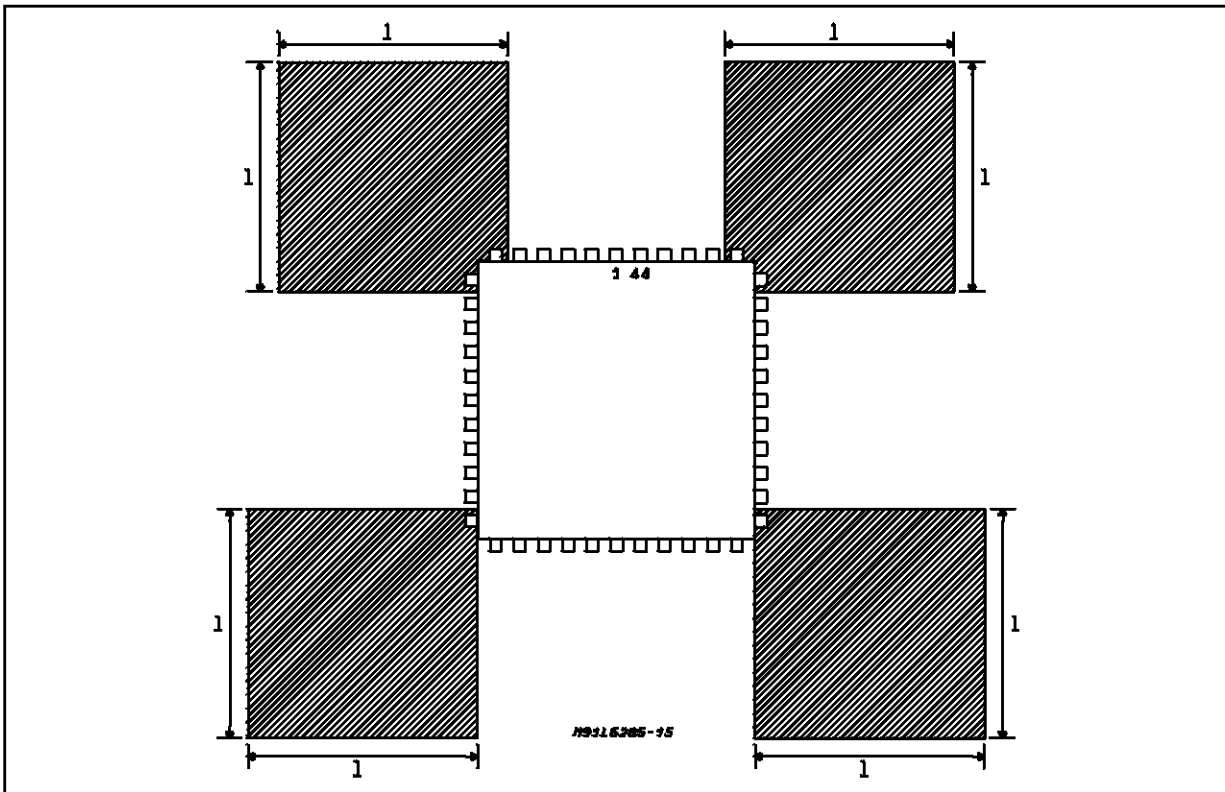

Figure 11: Typical $R_{th\ j-amb}$ vs. length "l" (Fig. 10)

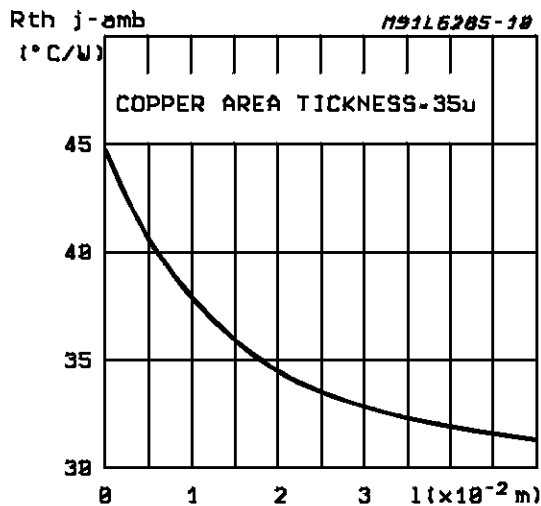
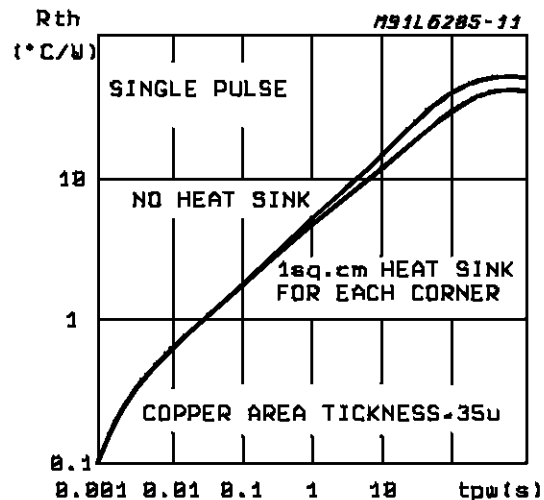

Figure 12: Typical Transient Thermal Resistance vs. Time or Pulse Width



L6285

SDIP42 PACKAGE MECHANICAL DATA

DIM.	mm			inch		
	MIN.	TYP.	MAX.	MIN.	TYP.	MAX.
A			5.08			0.20
A1	0.51			0.020		
A2	3.05	3.81	4.57	0.120	0.150	0.180
B	0.36	0.46	0.56	0.0142	0.0181	0.0220
B1	0.76	1.02	1.14	0.030	0.040	0.045
c	0.23	0.25	0.38	0.0090	0.0098	0.0150
D	37.85	38.10	38.35	1.490	1.50	1.510
E	15.24		16.00	0.60		0.629
E1	12.70	13.72	14.48	0.50	0.540	0.570
e		1.778			0.070	
e1		15.24			0.60	
e2			18.54			0.730
e3			1.52			0.060
L	2.54	3.30	3.56	0.10	0.130	0.140

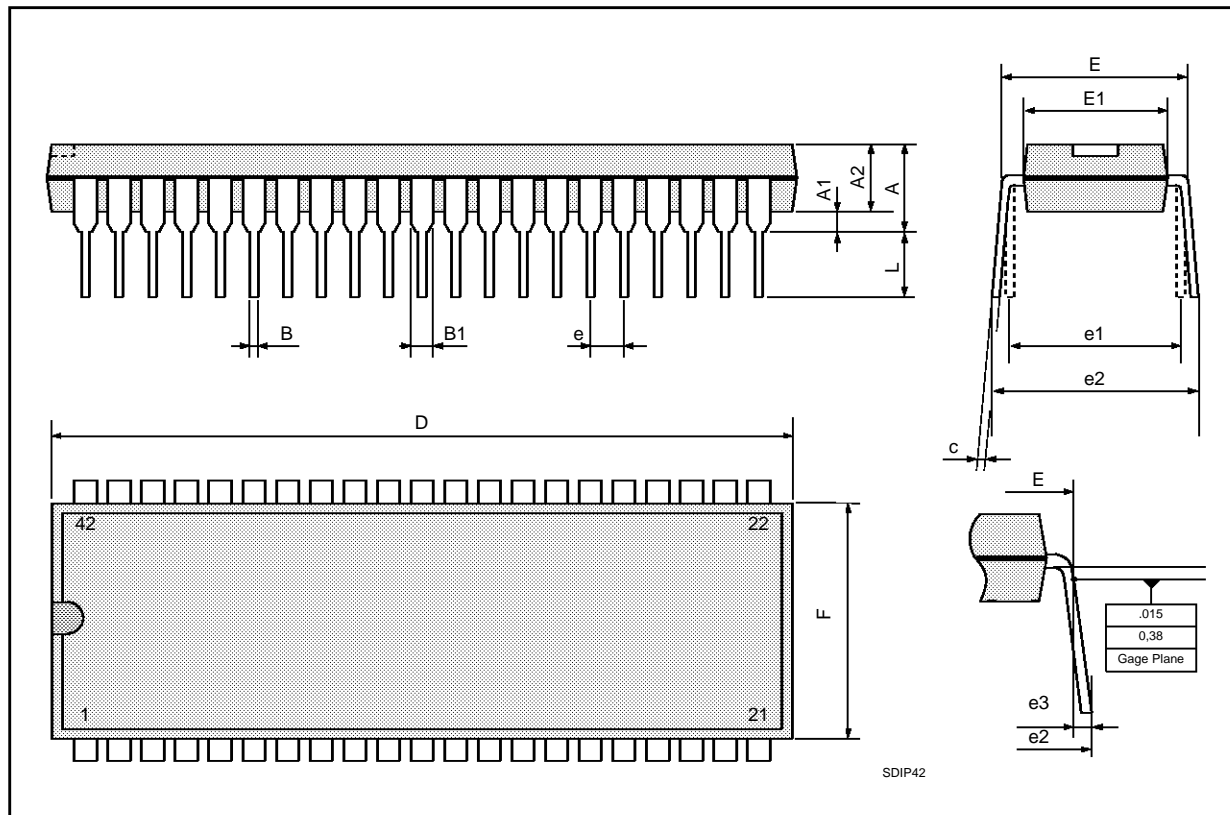

PLCC44 PACKAGE MECHANICAL DATA

DIM.	mm			inch		
	MIN.	TYP.	MAX.	MIN.	TYP.	MAX.
A	17.4		17.65	0.685		0.695
B	16.51		16.65	0.650		0.656
C	3.65		3.7	0.144		0.146
D	4.2		4.57	0.165		0.180
d1	2.59		2.74	0.102		0.108
d2		0.68			0.027	
E	14.99		16	0.590		0.630
e		1.27			0.050	
e3		12.7			0.500	
F		0.46			0.018	
F1		0.71			0.028	
G			0.101			0.004
M		1.16			0.046	
M1		1.14			0.045	

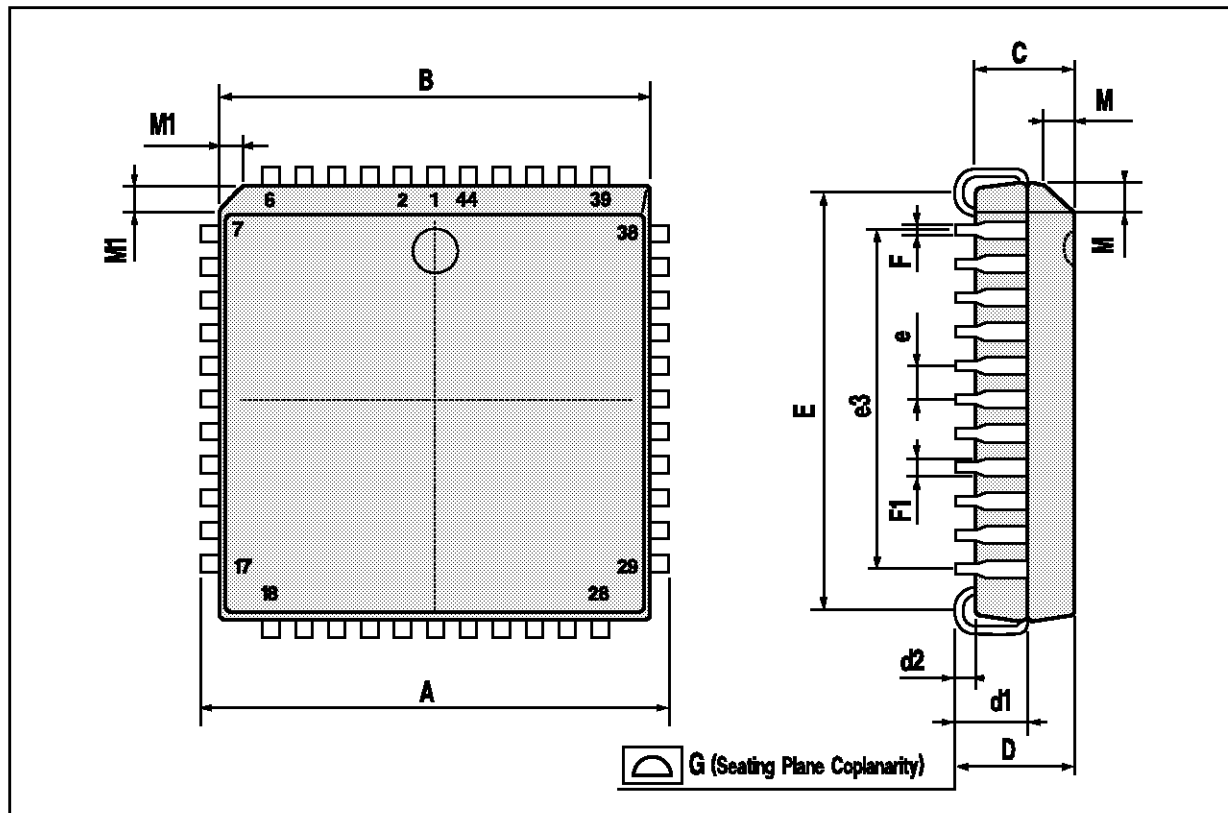

Information furnished is believed to be accurate and reliable. However, SGS-THOMSON Microelectronics assumes no responsibility for the consequences of use of such information nor for any infringement of patents or other rights of third parties which may result from its use. No license is granted by implication or otherwise under any patent or patent rights of SGS-THOMSON Microelectronics. Specifications mentioned in this publication are subject to change without notice. This publication supersedes and replaces all information previously supplied. SGS-THOMSON Microelectronics products are not authorized for use as critical components in life support devices or systems without express written approval of SGS-THOMSON Microelectronics.

© 1994 SGS-THOMSON Microelectronics - All Rights Reserved

SGS-THOMSON Microelectronics GROUP OF COMPANIES

Australia - Brazil - France - Germany - Hong Kong - Italy - Japan - Korea - Malaysia - Malta - Morocco - The Netherlands - Singapore - Spain
- Sweden - Switzerland - Taiwan - Thailand - United Kingdom - U.S.A.