



L6370

**2.5A HIGH-SIDE DRIVER
INDUSTRIAL INTELLIGENT POWER SWITCH**

- 2.5A OUTPUT CURRENT
- 9.5V TO 35V SUPPLY VOLTAGE RANGE
- INTERNAL CURRENT LIMITING
- THERMAL SHUTDOWN
- OPEN GROUND PROTECTION
- INTERNAL NEGATIVE VOLTAGE CLAMPING TO $V_S - 50V$ FOR FAST DEMAGNETIZATION
- DIFFERENTIAL INPUTS WITH LARGE COMMON MODE RANGE AND THRESHOLD HYSTERESIS
- UNDERVOLTAGE LOCKOUT WITH HYSTERESIS
- OPEN LOAD DETECTION
- TWO DIAGNOSTIC OUTPUTS
- OUTPUT STATUS LED DRIVER
- NON DISSIPATIVE SHORT CIRCUIT PROTECTION
- PROTECTION AGAINST AND SURGE TRANSIENT (IEC 801-5)
- IMMUNITY AGAINST BURST TRANSIENT (IEC 801-4)
- ESD PROTECTION (HUMAN BODY MODEL $\pm 2KV$)

MULTIPOWER BCD TECHNOLOGY

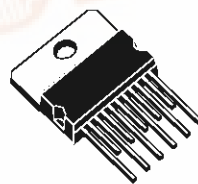

MULTIWATT11 (in line)

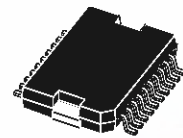

PowerSO20

ORDERING NUMBERS: L6370L (MULTIWATT11)
L6370D (PowerSO20)

DESCRIPTION

The L6370 is a monolithic Intelligent Power Switch in Multipower BCD Technology, for driving inductive or resistive loads. An internal Clamping Diode enables the fast demagnetization of inductive loads. Diagnostic for CPU feedback and extensive use of electrical protections make this device extremely rugged and specially suitable for industrial automation applications.

BLOCK DIAGRAM

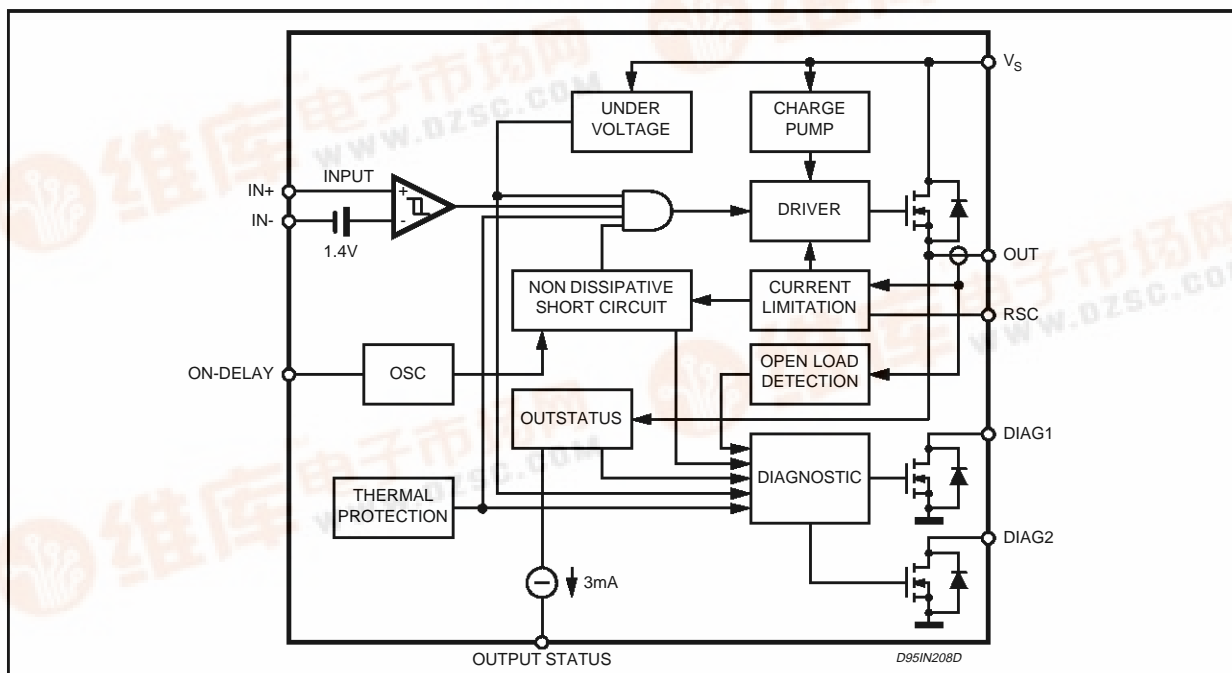

L6370

PIN CONNECTION (Top view)

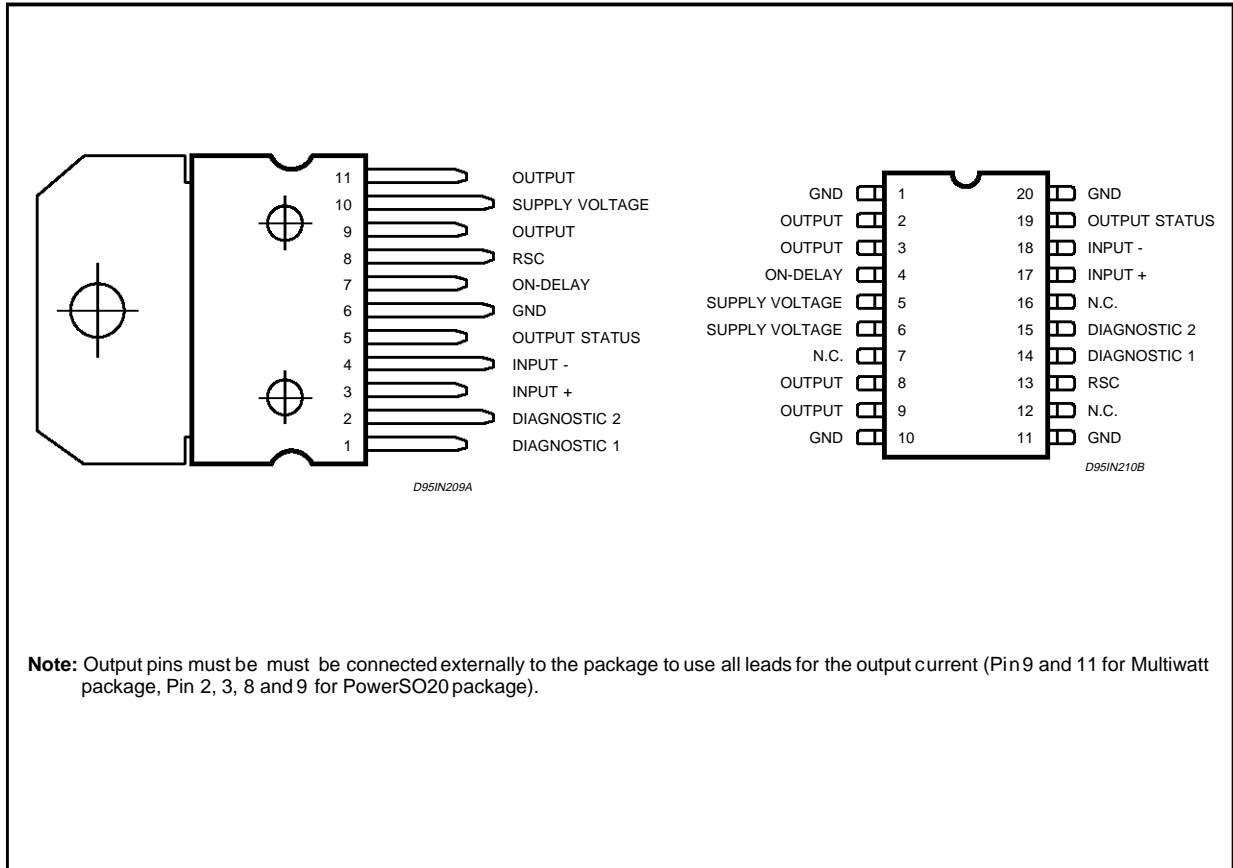

ABSOLUTE MAXIMUM RATINGS (Pin numbering referred to Multiwatt package)

Symbol	Parameter	Value	Unit
V_S	Supply Voltage (Pin 10) ($T_W < 10\text{ms}$)	50	V
$V_S - V_O$	Supply to Output Differential Voltage. See also V_{CI} (Pins 10 - 9)	internally limited	V
V_{od}	Externally Forced Voltage (Pin7)	-0.3 to 7_I	V
I_{od}	Externally Forced Voltage (Pin7)	± 1	mA
V_i	Input Voltage (Pins 3/4)	-10 to $V_S + 10$	V
V_i	Differential Input Voltage (Pins 3 - 4)	43	V
I_i	Input Current (Pins 3/4)	20	mA
I_O	Output Current (Pin 9). See also ISC (Pin 9)	internally limited	A
P_{tot}	Power Dissipation. See also THERMAL CHARACTERISTICS.	internally limited	W
T_{op}	Operating Temperature Range (T_{amb})	-25 to +85	°C
T_{stg}	Storage Temperature	-55 to 150	°C
E_I	Energy Induct. Load $T_J = 85^\circ\text{C}$	1	J

THERMAL DATA

Symbol	Description		Multiwatt	PowerSO20	Unit
$R_{th\ j\text{-case}}$	Thermal Resistance Junction-case	Max.	1.5	1.5	°C/W
$R_{th\ j\text{-amb}}$	Thermal Resistance Junction-ambient	Max.	35	-	°C/W

PIN FUNCTION (pin numbering referred to Multiwatt package)

N.	Name	Function
1	DIAG1	DIAGNOSTIC 1 output. This open drain reports the IC working conditions. (See Diagnostic truth table)
2	DIAG1	DIAGNOSTIC 2 output. This open drain reports the IC working conditions. (See Diagnostic truth table)
3	IN -	Comparator non inverting input
4	IN+	Comparator inverting input
5	OUTSTATUS	This current source output is capable of driving a LED to signal the status of the output pin. The pin is active (source current) when the output pin is considered high (See fig 1)
6	GND	Ground
7	ON-DELAY	Programmable ON time interval duration during short circuit operation
8	RSC	Current limitation setting.
9	OUTPUT	High Side output with built-in current limitation
10	V _S	Supply Voltage Input, the value of the supply voltage is monitored to detect under voltage condition
11	OUTPUT	High Side output with built-in current limitation

ELECTRICAL CHARACTERISTICS (V_S = 24V; T_J = -25 to +125°C, unless otherwise specified)

Symbol	Parameter	Test Condition	Min.	Typ.	Max.	Unit
V _{smin}	Supply Voltage for Valid Diagnostics	I _{diag} > 0.5mA ; V _{dg1} = 1.5V	4		35	V
V _S	Supply Voltage (operative)		9.5	24	35	V
I _q	Quiescent Current I _{out} = I _{os} = 0	V _{il} V _{ih}		0.8 3	1.4 5	mA mA
V _{sth1}	Undervoltage Threshold 1	(See fig. 1), T _{amb} = 0 to +85°C	8.5	9	9.5	V
V _{sth2}	Undervoltage Threshold 2		8	8.5	9	V
V _{shvs}	Supply Voltage Hysteresis		300	500	700	mV
I _{sc}	Short Circuit Current	V _S = 9.5 to 35V; R _L = 2Ω 5kΩ < R _{SC} < 30kΩ 0 < R _{SC} < 5kΩ	15/R _{SC} (kΩ)			A A
V _{don}	Output Voltage Drop	I _{out} = 2.0A T _J = 25°C T _J = 125°C I _{out} = 2.5A T _J = 25°C T _J = 125°C		200 320 250 400	280 440 350 550	mV mV mV mV
I _{oslk}	Output Leakage Current	V _i = V _{il} ; V _o = 0V			500	μA
V _{ol}	Low State Out Voltage	V _i = V _{il} ; R _L = ∞		0.8	1.5	V
V _{cl}	Internal Voltage Clamp (V _S - V _O)	I _O = 1A Single Pulsed: T _p = 300μs	48	53	58	V
I _{old}	Open Load Detection Current	V _i = V _{ih} ; T _{amb} = 0 to +85°C	1	3	6	mA
V _{id}	Common Mode Input Voltage Range (Operative)	V _S = 18 to 35V	-7		15	V
I _{ib}	Input Bias Current	V _i = -7 to 15V; -I _n = 0V	-250		250	μA
V _{ith}	Input Threshold Voltage	V+In > V-In	0.8	1.4	2	V
V _{iths}	Input Threshold Hysteresis Voltage	V+In > V-In	50		400	mV
R _{id}	Diff. Input Resistance	0 < +In < +16V; -In = 0V -7 < +In < 0V; -In = 0V		400 150		KΩ KΩ
I _{iik}	Input Offset Current	V+In = V-In 0V < V _i < 5.5V	+li -li	-20 -75	+20	μA μA
		-In = GND 0V < V+In < 5.5V	+li -li	-250 -125	+50	μA μA
		+In = GND 0V < V-In < 5.5V	+li -li	-100 -50		μA μA

ELECTRICAL CHARACTERISTICS (continued)

Symbol	Parameter	Test Condition	Min.	Typ.	Max.	Unit
V_{oth1}	Output Status Threshold 1 Voltage	(See fig. 1)	4.5	5	5.5	V
V_{oth2}	Output Status Threshold 2 Voltage	(See fig. 1)	4	4.5	5.0	V
V_{ohys}	Output Status Threshold Hysteresis	(See fig. 1)	300	500	700	mV
I_{osd}	Output Status Source Current	$V_{out} > V_{oth1}$; $V_{os} = 2.5V$	2		4	mA
V_{osd}	Active Output Status Driver Drop Voltage	$V_s - V_{os}$; $I_{os} = 2mA$ $T_{amb} = 0$ to $+85^{\circ}C$		1.5	3	V
I_{oslk}	Output Status Driver Leakage Current	$V_{out} < V_{oth2}$; $V_{os} = 0V$ $V_s = 9.5$ to $35V$			25	μA
V_{dgl}	Diagnostic Drop Voltage	$D1 / D2 = L$; $I_{diag} = 0.5mA$ $D1 / D2 = L$; $I_{diag} = 3mA$		40 250		mV mV
I_{dglk}	Diagnostic Leakage Current	$D1 / D2 = H$; $0 < V_{dg} < V_s$ $V_s = 9.5$ to $35V$			5	μA

SOURCE DRAIN NDMOS DIODE

V_{fsd}	Forward On Voltage	@ $I_{fsd} = 2.5A$		1	1.5	V
I_{fp}	Forward Peak Current	$t = 10ms$; $d = 20\%$			6	A
t_{rr}	Reverse Recovery Time	$I_f = 2.5A$ $di/dt = 25A/\mu s$		200		ns
t_{fr}	Forward Recovery Time			100		ns

THERMAL CHARACTERISTICS

Θ_{Lim}	Junction Temp. Protect.		135	150		$^{\circ}C$
ΘT_H	Thermal Hysteresis			20		$^{\circ}C$

Note $V_{il} \leq 0.8V$, $V_{ih} \geq 2V$ @ ($V+In > V-In$)

AC OPERATION (pin numbering referred to Multiwatt package)

Symbol	Pin	Parameter	Test Condition	Min.	Typ.	Max.	Unit
$t_r - t_f$	9 vs 4	Rise or Fall Time	$V_s = 24V$; $R_l = 70\Omega$; R_l to ground		20		μs
t_d	9 vs 3	Delay Time			5		μs
dV/dt	9, 11	Slew Rate (Rise and Fall Edge)		0.7	1	1.5	$V/\mu s$
t_{ON}	7	On time during Short Circuit Condition	$50pF < C_{DON} < 2nF$		1.28		$\mu s/pF$
t_{OFF}		Of time during hort Circuit Condition			64		t_{ON}
f_{max}		Maximum Operating Frequency			25		KHz

Figure 1: Output Status Hysteresis

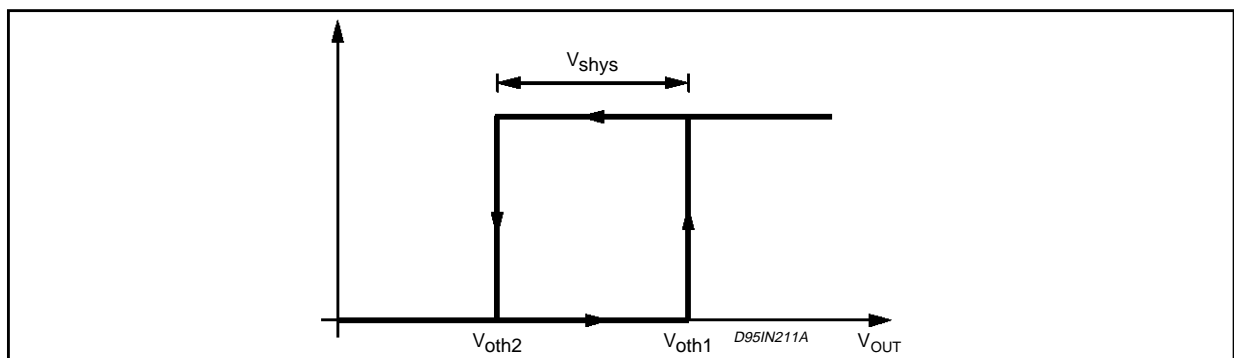

Figure 2: Undervoltage Comparator Hysteresis

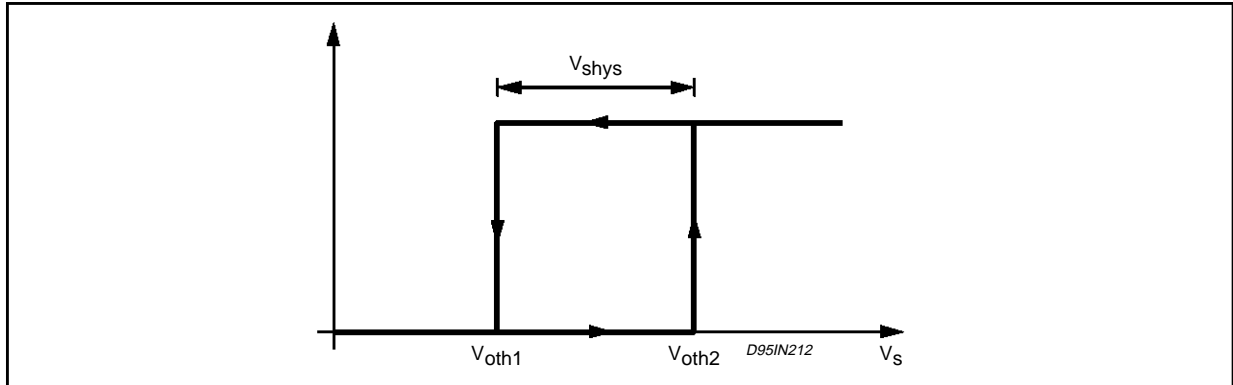
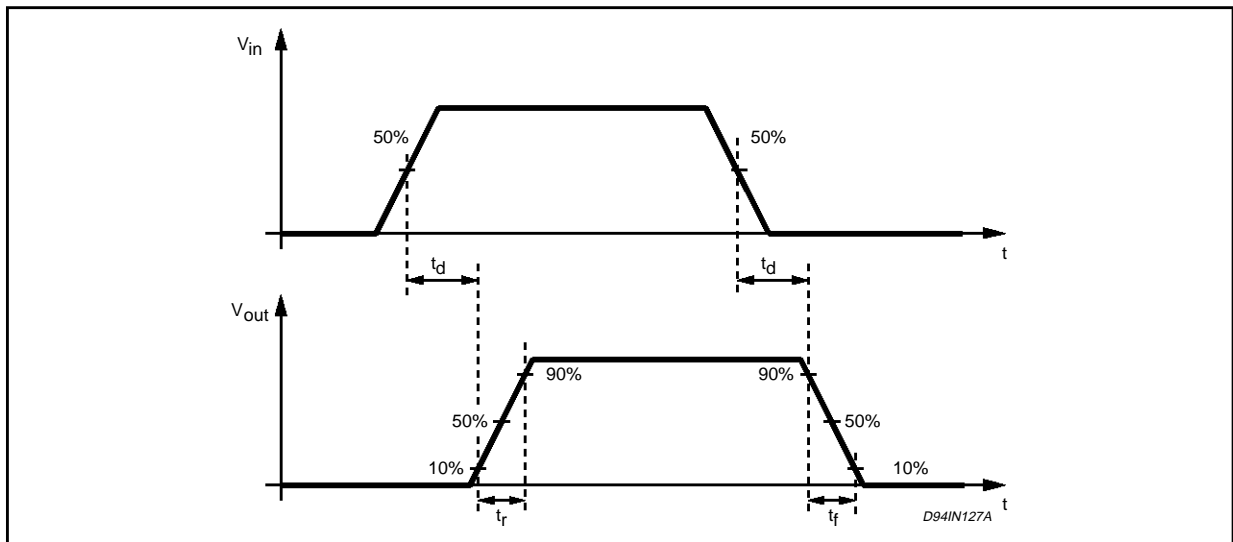

Figure 3: Switching Waveforms



DIAGNOSTIC TRUTH TABLE

Diagnostic Conditions	Input	Output	Diag1	Diag2
Normal Operation	L H	L H	H H	H H
Open Load Condition ($I_o < I_{old}$)	L H	L H	H L	H H
Short to V_s	L H	H H	L L	H H
Short Circuit to Ground ($I_o = I_{sc}$) (**) (pin ON-DELAY grounded)	H	H (*) L	H H	H H
Output DMOS Open	L H	L L	H L	H H
Overtemperature	L H	L L	H H	L L
Supply Undervoltage ($V_s < V_{sth2}$)	L H	L L	L L	L L

(*) According to the intervention of the current limiting block.

(**) A cold lamp filament, or a capacitive load may activate the current limiting circuit of the IPS, when the IPS is initially turned on.

INPUT SECTION

The input section is a high impedance differential stage with high common and differential mode range. There's built-in offset of +1.4V (typical value) and an hysteresis of 400mV (maximum value), to ensure high noise immunity.

DIAGNOSTIC LOGIC

The operating conditions of the device are permanently monitored and the following occurrences are signalled via the DIAG1/DIAG2 open-drain output pins:

- Short Circuit versus ground.
A current limiting circuit fixes at $I_{sc} = 3.2A$ (typical value) the maximum current that can be sourced from the OUTPUT pin (for more details see short circuit operation section).
- Short Circuit versus V_s .
- Under Voltage(UV)
- Over Temperature (OVT)
- Open Load, if the output current is less than 3mA (typical value).
- Output DMOS Open
according to the diagnostic Truth Table:

SHORT CIRCUIT OPERATION

in order to minimise the power dissipation when the output is shorted to ground, an innovative, non dissipative short circuit protection (patent pending) is implemented, avoiding, thus the intervention of the thermal protection in most cases.

Whenever the output is shorted to ground, or, generally speaking, an over current is sunk by the load, the output devices is driven in linear mode, sourcing the I_{sc} current (typically 3.2A) for a time interval (t_{on}) defined by means of the external C_{ON} capacitor connected between the ON-DELAY pin and GND. Whether the short circuit crease within the t_{on} interval the DIAG2 output status is not affected, acting as a Programmable Diagnostic Delay.

This function allow the device to drive a capacitive load or a filament lamp (that exhibits a very low resistance during the initial heading phase) without the intervention of the diagnostic.

If the short circuit lasts for the whole t_{ON} interval, the output DMOS is switched OFF and the DIAG2 goes low, for a time interval t_{OFF} lasting 64 times t_{ON} .

At the end of the t_{OFF} interval if the short circuit condition is still present, the output DMOS is turned ON (and the DIAG2 goes high - see fig4) for another t_{ON} interval and the sequence starts again, or, whether not, the normal condition op-

eration is resumed.

The t_{ON} interval can be set to lasts between 64 μs and 2.56ms for a C_{ON} capacitor value ranging between 50pF and 2nF to have:

$$t_{ON} (\mu s) = 1.28 C_{ON} (pF)$$

If the ON-DELAY pin is grounded the non dissipative short circuit protection is disabled, and the I_{sc} current is delivered until the Overtemperature Protection shuts the device off. The behaviour of the DIAG2 output is, in this situation, showed in the Diagnostic Truth Table.

OVERTEMPERATURE PROTECTION (OVT)

If the chip temperature exceeds Θ_{lim} (measured in a central position in the chip) the chip deactivates itself.

The following actions are taken:

all the output stage is switched off;

the signal DIAG2 is activated (active low).

Normal operation is resumed as soon as (typically after some seconds) the chip temperature monitored goes back below $\Theta_{lim} - \Theta_H$.

The different thresholds with hysteretic behavior assure that no intermittent conditions can be generated.

UNDERVOLTAGE PROTECTION (UV)

The supply voltage is expected to range from 9.5V to 35V, even if its reference value is considered to be 24V.

In this range the device operates correctly.

Below 9.5V the overall system has to be considered not reliable.

Protection will thus shut off the output whenever the supply voltage falls below the mask fixed by the V_{sth1} (9V typ.) and V_{sth2} (8.5V typ.).

The hysteresis (see fig. 2) ensures a non intermittent behavior at low supply voltage with a superimposed ripple.

The Under Voltage status is signalled via the DIAG1 and DIAG2 outputs (see the Diagnostic Truth Table).

DEMAGNETIZATION OF INDUCTIVE LOADS

An internal zener diode, limiting the voltage across the Power MOS, to between 50 and 60V (V_{cl}), provides safe and fast demagnetization of inductive loads without external clamping devices.

The maximum energy that can be absorbed from an inductive load is specified as 1J (at $T_j = 85^\circ C$) (see figure 2)

Figure 4: L6370 Short Circuit Operation Waveforms

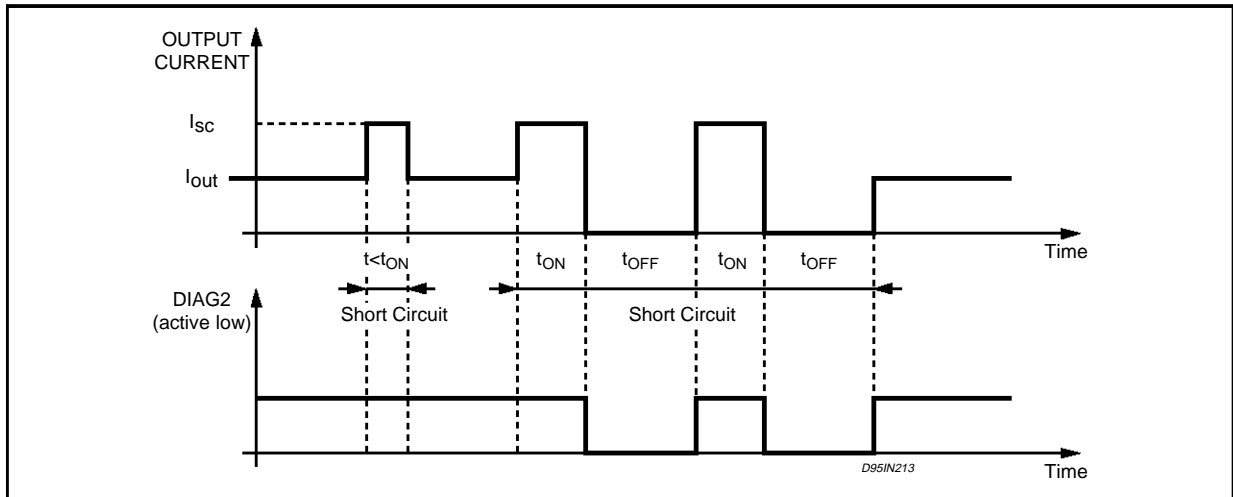
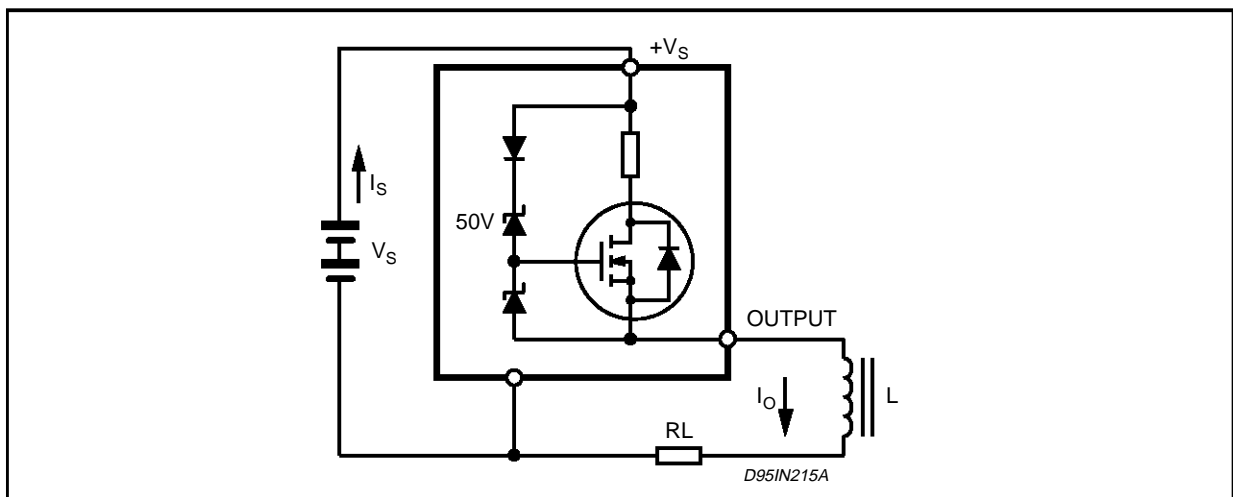

Figure 5: Inductive Load Equivalent Circuit



L6370

MULTIWATT11 (in line) PACKAGE MECHANICAL DATA

DIM.	mm			inch		
	MIN.	TYP.	MAX.	MIN.	TYP.	MAX.
A			5			0.197
B			2.65			0.104
C			1.6			0.063
E	0.49		0.55	0.019		0.022
F	0.88		0.95	0.035		0.037
G	1.57	1.7	1.83	0.062	0.067	0.072
G1	16.87	17	17.13	0.664	0.669	0.674
H1	19.6			0.772		
H2			20.2			0.795
L	26.4		26.9	1.039		1.059
L1	22.35		22.85	0.880		0.900
L3	17.25	17.5	17.75	0.679	0.689	0.699
L4	10.3	10.7	10.9	0.406	0.421	0.429
L7	2.65		2.9	0.104		0.114
S	1.9		2.6	0.075		0.102
S1	1.9		2.6	0.075		0.102
Dia1	3.65		3.85	0.144		0.152

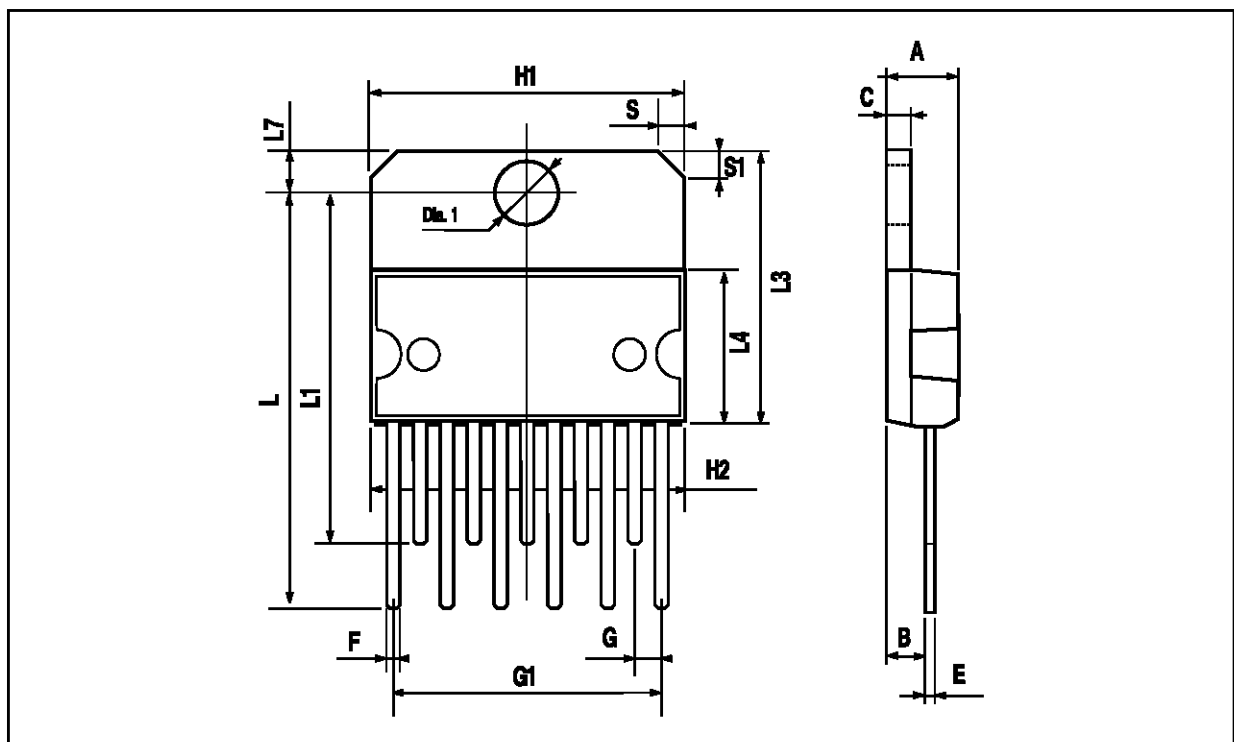

PowerSO20 PACKAGE MECHANICAL DATA

DIM.	mm			inch		
	MIN.	TYP.	MAX.	MIN.	TYP.	MAX.
A			3.60			0.1417
a1	0.10		0.30	0.0039		0.0118
a2			3.30			0.1299
a3	0		0.10	0		0.0039
b	0.40		0.53	0.0157		0.0209
c	0.23		0.32	0.009		0.0126
D (1)	15.80		16.00	0.6220		0.6299
E	13.90		14.50	0.5472		0.570
e		1.27			0.050	
e3		11.43			0.450	
E1 (1)	10.90		11.10	0.4291		0.437
E2			2.90			0.1141
G	0		0.10	0		0.0039
h			1.10			
L	0.80		1.10	0.0314		0.0433
N	10° (max.)					
S	8° (max.)					
T		10.0			0.3937	

(1) "D and E1" do not include mold flash or protrusions
 - Mold flash or protrusions shall not exceed 0.15mm (0.006")

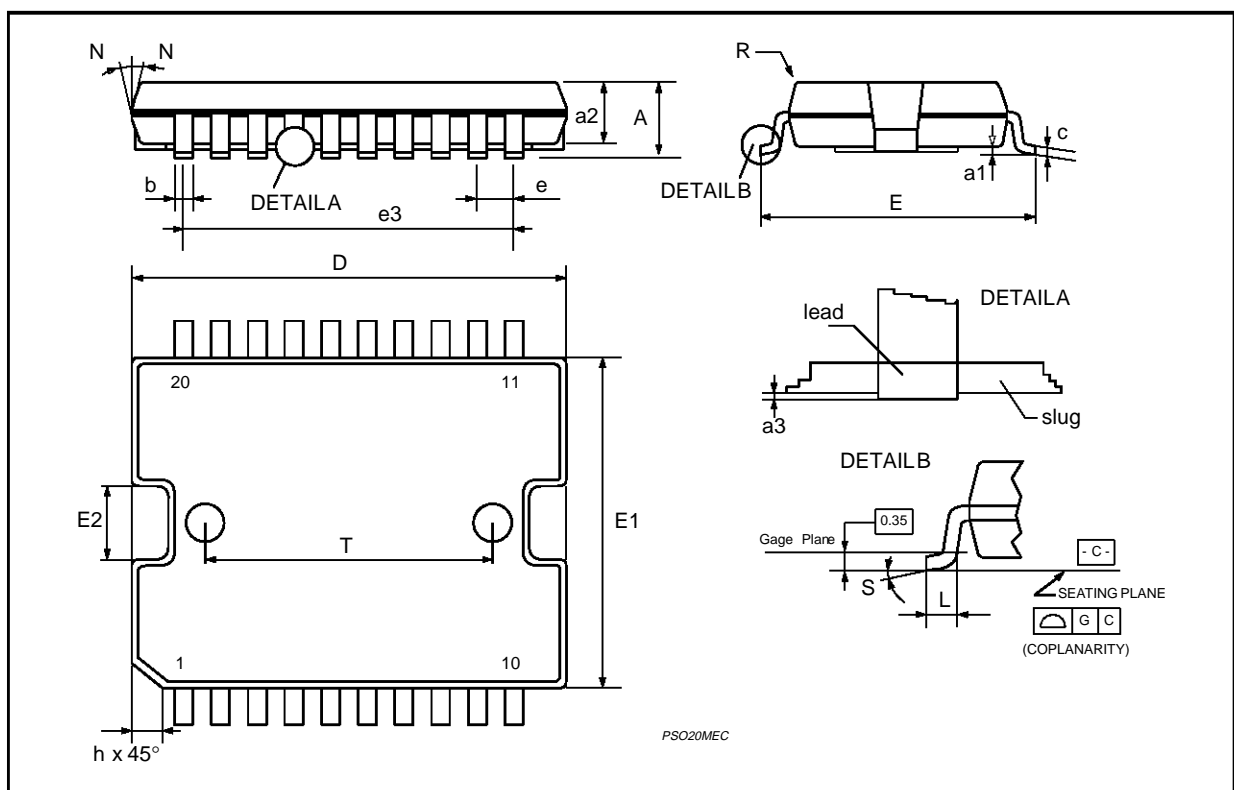

Information furnished is believed to be accurate and reliable. However, SGS-THOMSON Microelectronics assumes no responsibility for the consequences of use of such information nor for any infringement of patents or other rights of third parties which may result from its use. No license is granted by implication or otherwise under any patent or patent rights of SGS-THOMSON Microelectronics. Specifications mentioned in this publication are subject to change without notice. This publication supersedes and replaces all information previously supplied. SGS-THOMSON Microelectronics products are not authorized for use as critical components in life support devices or systems without express written approval of SGS-THOMSON Microelectronics.

© 1997 SGS-THOMSON Microelectronics – Printed in Italy – All Rights Reserved

MULTIWATT® is a Registered Trademark of SGS-THOMSON Microelectronics

PowerSO20™ is a Trademark of SGS-THOMSON Microelectronics

SGS-THOMSON Microelectronics GROUP OF COMPANIES

Australia - Brazil - Canada - China - France - Germany - Hong Kong - Italy - Japan - Korea - Malaysia - Malta - Morocco - The Netherlands - Singapore - Spain - Sweden - Switzerland - Taiwan - Thailand - United Kingdom - U.S.A.