



L6515

DUAL DC-MOTOR POSITIONING SYSTEM

ADVANCE DATA

- PRECISE OPERATION ALSO WITH LOW COST OPTICAL ENCODER
- PWM - OUTPUT FOR DIGITAL SWITCHED POWER BRIDGES
- DIRECTION INDICATOR FOR EASY POSITION COUNTING WITH μP
- EXTERNAL LOOP GAIN AND TRANSFER FUNCTIONAL ADJUSTMENT
- PARALLEL ADDRESSED INPUTS WITH LATCH
- 44 LEAD PLCC PACKAGE

DESCRIPTION

The L6515 is a monolithic integrated circuit in BCD-Technology assembled in a PLCC-44 plastic chip carrier.

The device contains all functions for a complete dual DC-Motor positioning system. For the motor driver stage only digital switched bridges are needed.

MULTIPOWER BCD TECHNOLOGY

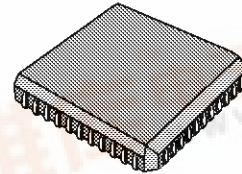

PLCC44

ORDERING NUMBER: L6515

Useful are L293E, L298, L6203 and L6202. The device is intended to drive DC-Motors in typewriters, printers, plotters and general purpose industrial applications.

SYSTEM BLOCK DIAGRAM (ONE CHANNEL)

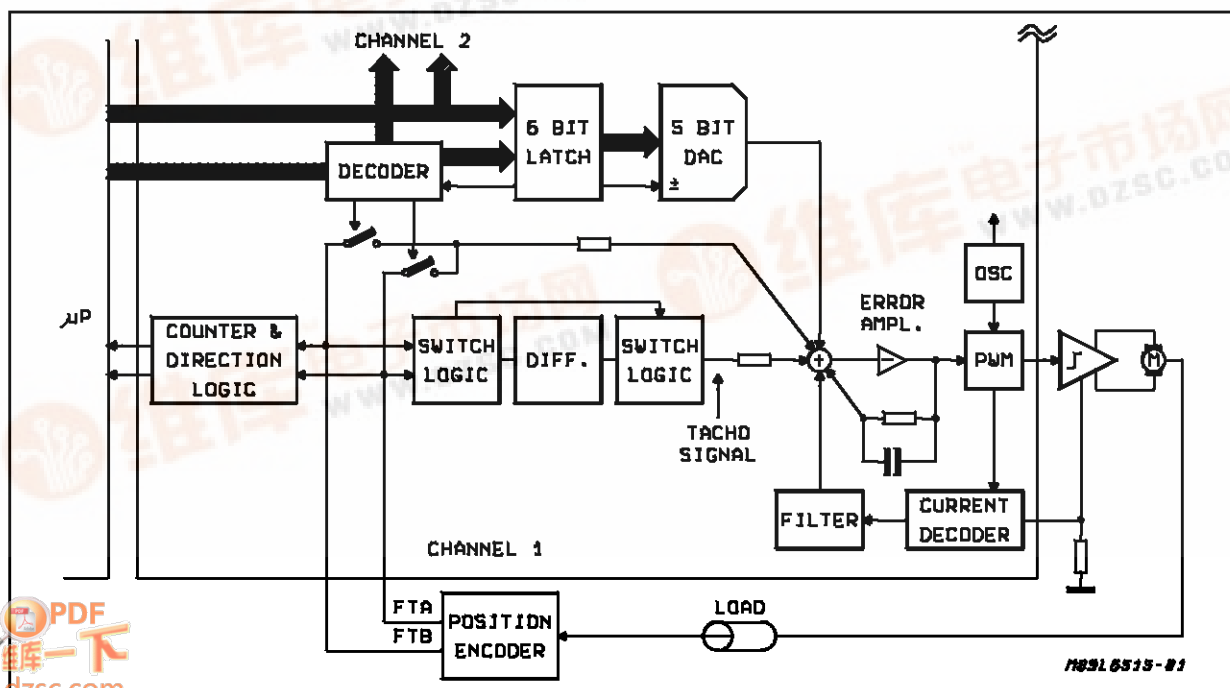

1891.6515-01

L6515

ABSOLUTE MAXIMUM RATINGS

Symbol	Parameter	Value	Unit
V_S	Supply Voltage	12	V
V_{IA}	Analog Inputs Voltage	-0.3 to 7	V
V_{IL}	Logic Inputs Voltage	-0.3 to 7	V
V_O	Open Collector Output Current	12	V
I_o	Open Collector Current	10	mA
I_z	Zener Current	20	mA
T_{stg}, T_j	Storage Temperature	-40 to 150	°C
T_{amb}	Operative Ambient Temperature	0 to 70	°C

PIN CONNECTION (top view)

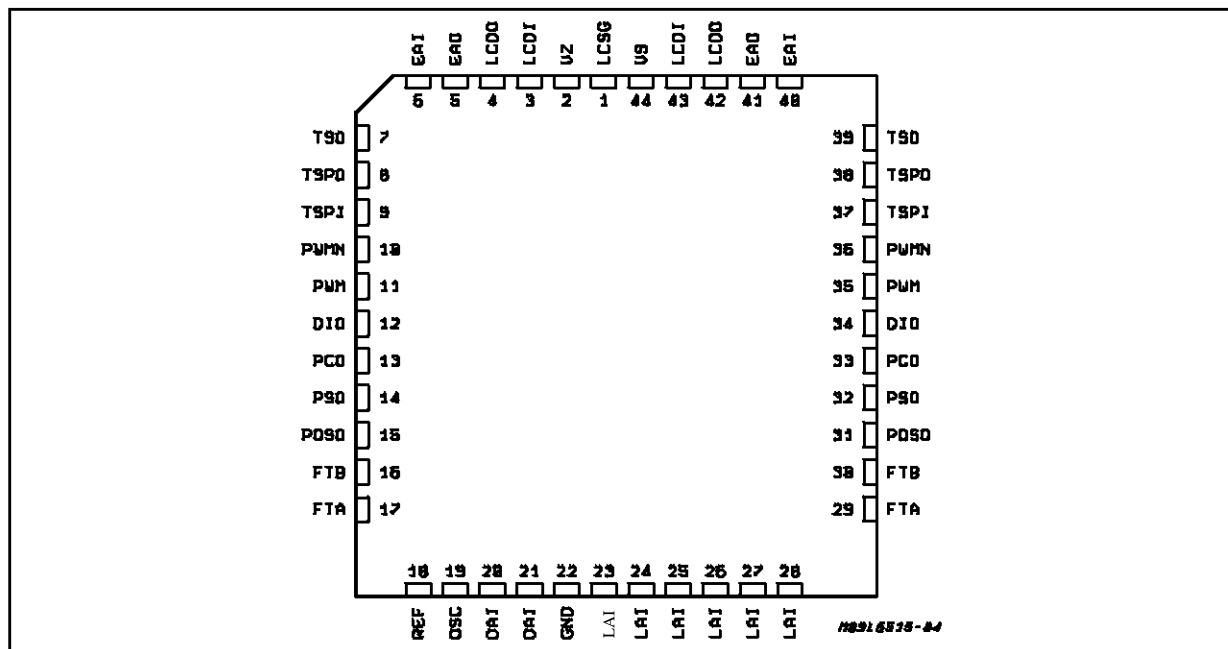

SYSTEM DESCRIPTION

The L6515 is intended to be used as a microprocessor controlled positioning system.

For the motor driver stage only digital operating bridges are needed like L293E, L298, L6203, L6202.

The system operates in two modes to achieve high-speed, high-accuracy positioning.

Speed commands for the system originate in the microprocessor. It is continuously updated on the motor position by means of pulses from the controller chip, which in turn gets its information from the encoder. From this basic input, the microprocessor computes a 6-bit control word that sets the system speed and direction dependent on the distance to travel.

When the motor is stopped and the microprocessor orders it to a new position, the system oper-

ates initially in an open-loop configuration as there is no feedback from the tachometer generator. Therefore maximum current is fed to the motor. As maximum speed is reached, the tachometer chip output backs off the processors signal thus reducing accelerating torque. The motor continues to run at top speed but under closed-loop control.

As a target position is approached, the microprocessor lowers the value of the speed-demand word; this reduces the voltage at the main summing point, in effect braking the motor. The braking is applied progressively until the motor is running at minimum speed.

At that time, the microprocessor orders a switch to the position mode, and within 3 to 4ms the power stage drives the motor to a null position, where it is held by electronic "detening".

PIN FUNCTIONS

Pin	Name	Description
1	LCSG	Load Current Decoder Sens Reference Ground
2	V _Z	Zener Clamp
3,43	LCDI	Load Current Decoder Input
4,42	LCDO	Load Current Decoder Output
5,41	EAO	Error Amplifier Output for Current Mode PWM Modulator
6,40	EAI	Error Amplifier Input for Current Mode PWM Modulator
7,39	TSO	Tacho Signal Output
8,38	TSPO	Tacho Signal Processor Output
9,37	TSPI	Tacho Signal Processor Input
10,36	PWMN	Current Mode PWM Output Inverted
11,35	PWM	Current Mode PWM Output non Inverted
12,34	DIO	Direction Indicator Digital Open Collector Output. A Low Level is cw, A High Level is ccw Operation of the Motor
13,33	PCO	Position Counter Digital Open Collector Output
14,32	PSO	Phase Selector Output for Signal Differentiation
15,31	POSO	Positioning Output. The Output Becomes Activated via Position Adress Decoder.
16,30	FTB	Analog Input from Position Encoder Phase B. Proposed Operation Range is 2.8V ± 1V.
17,29	FTA	Analog Input from Position Encoder Phase A. Proposed Operation Range is 2.8V ± 1V
18	REF	Master Current Reference
19	OSC	Oscillator
20,21	DAI	Decoder Logic Input for Latch Select + Reset
22	GND	Major and Logic Ground
23 to 28	LAI	Latch Adress Input
44	V _S	Supply Voltage

SCHEMATIC DIAGRAM

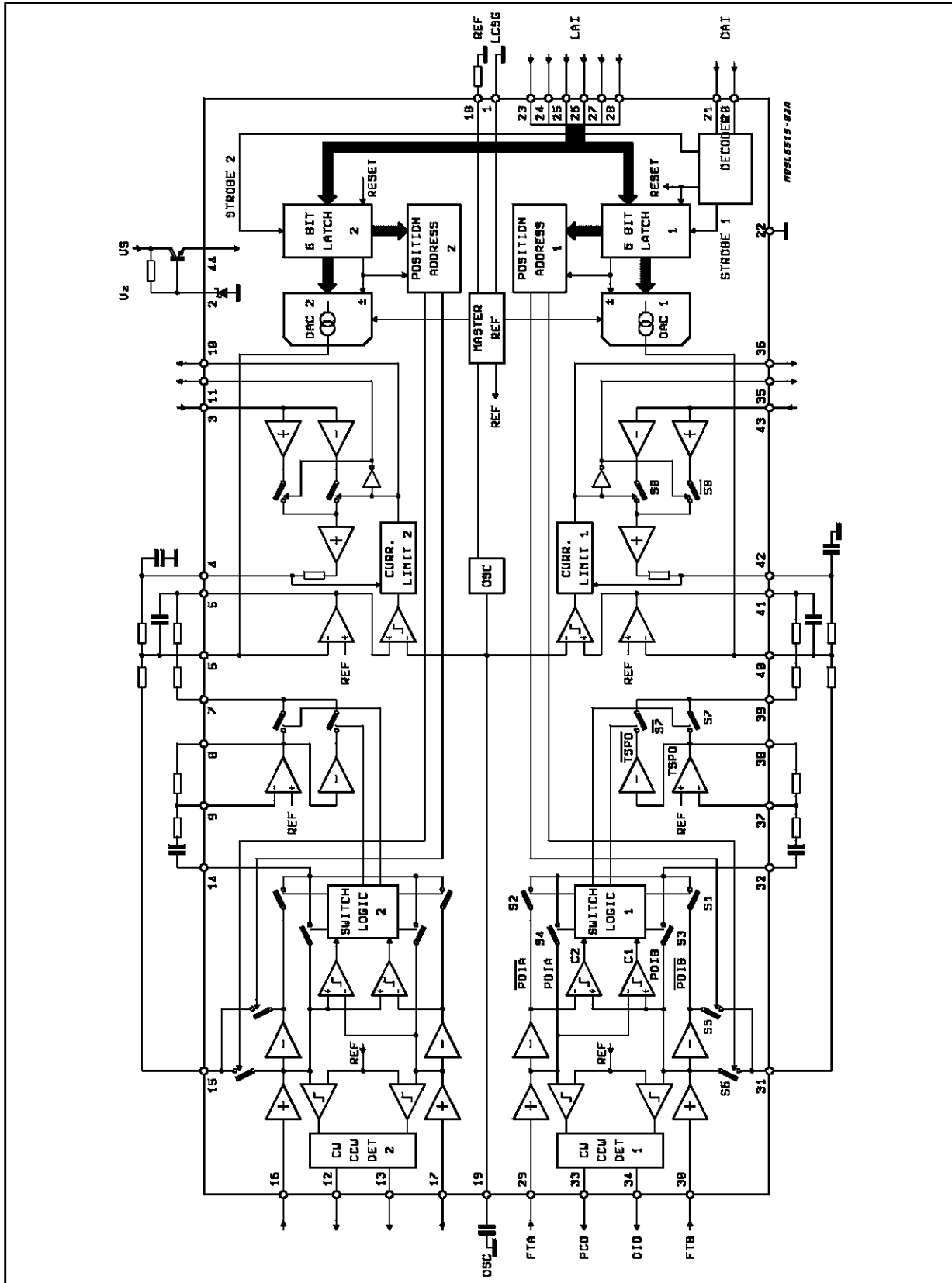

APPLICATION CIRCUIT

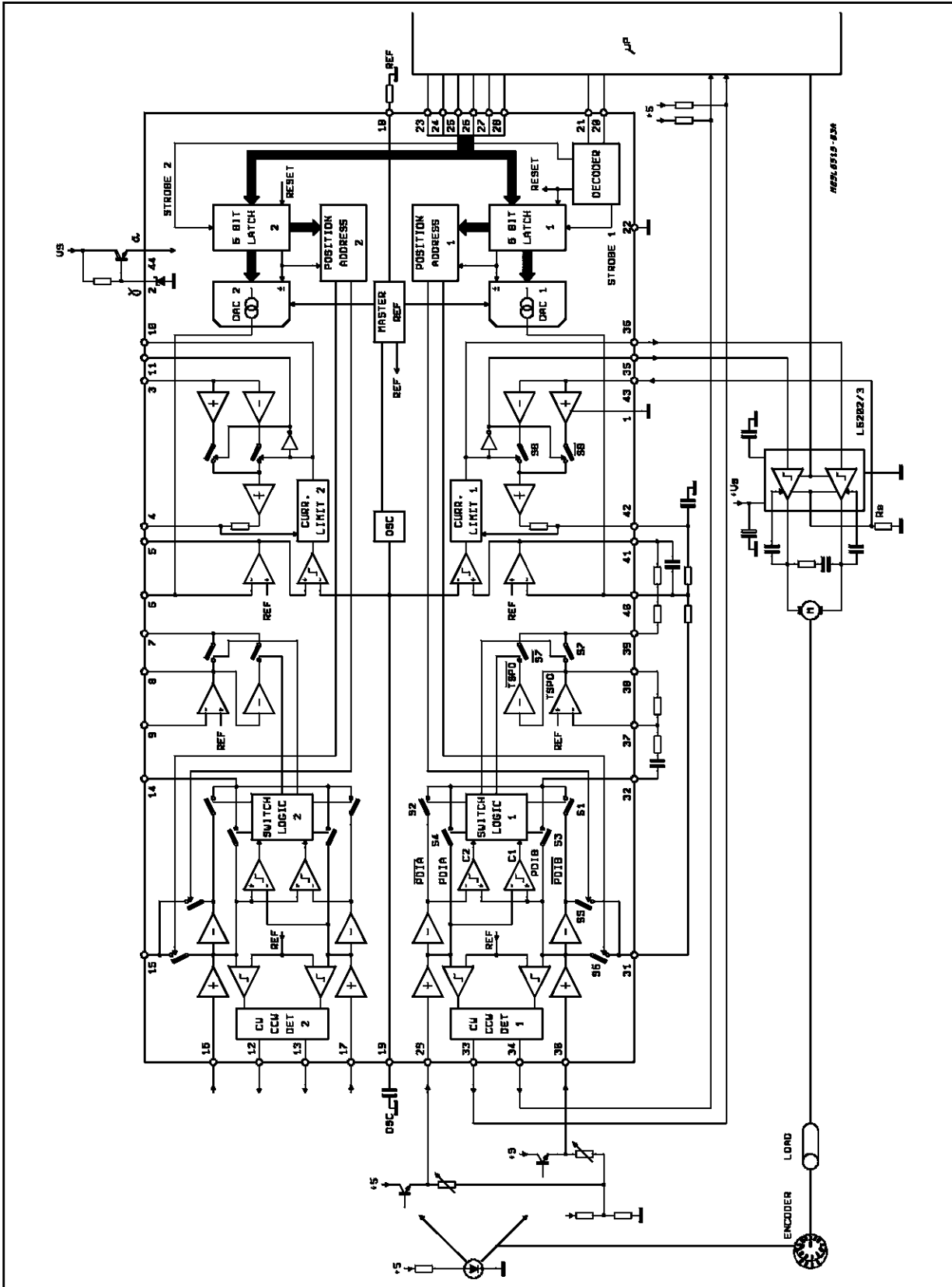

L6515

ELECTRICAL CHARACTERISTICS (refer to test circuit, $V_S=10V$, $I_{REF}=300\mu A$, $T_{amb}=25\text{ }^\circ C$ unless otherwise specified)

Symbol	Parameter	Pin	Test Condition	Min.	Typ.	Max.	Unit
V_S	Operating Supply Voltage Range			7		11	V
I_S	Quiescent supply current					50	mA
V_Z	Zener Voltage		$I_Z=1mA$	8,5	9.9	11,4	V
I_Z	Operating Zener Current			1			mA

POSITION ENCODER SECTION

V_I	Operating Input Voltage Range	A/D/1/2	referred to V_{REF}	-1,65		+1,65	V
I_I	Input Bias Current					1	μA
V_{OS}	INput-output Offset Voltage Between A/D/1/2 and F/1/2		S3 or S4 closed $I_o=0$			± 15	mV
			S1 or S2 closed $I_o=0$ $V_{IN}=V_{REF}$			± 20	mV
V_{SAT}	Output Saturation Voltage	B/C/1/2	$I_o=1.4mA$			0.4	V
I_{OH}	Output Leakage Current					10	μA
V_{TH}	Threshold Hysteresis voltage Between A/1/2 and B/1/2 D/1/2 and C/1/2			80		150	mV
R_{ON}	Output Resistance ON State	E/F/1/2	One of S1 to S6 closed		150	300	Ω
V_{OL}	Output Operating Low Voltage	E/F/1/2	referred to V_{REF} $I_o=1mA$			-1.2	V
V_{OH}	Output Operating High Voltage			+1.2			V

TACHO SIGNAL PROCESSING SECTION

Symbol	Parameter	Pin	Test Condition	Min.	Typ.	Max.	Unit
V_I	Input Voltage	G/1/2	gain=1 referred to V_{REF}	-1.65		+1.65	V
I_I	Input Bias Current						
V_{OL}	Output Operating Low Voltage	H/1/2	referred to V_{REF} $I_o=1mA$ $\overline{S7}$ closed			-1.62	V
		I/1/2				-1.3	
V_{OH}	Output Operating low Voltage	I/1/2				+1.3	
		H/1/2				+1.62	
R_{ON}	Output Resistance On State	I1/2	S7 or $\overline{S7}$ closed		150	260	Ω
V_{OS}	Input Offset Voltage	H1/2	$V_{IN}=V_{REF}$ S7 closed $I_o = 0$			± 20	mV
V_{OS}	Input Offset Voltage	G1/2	referred to V_{REF} g1/2 shorted to H1/2			± 20	mV
R_{MO}	Output Matching Resistance	I1/2	S7 or $\overline{S7}$ closed	0.8		1.2	Ω

ERROR AMPLIFIER SECTION

V_I	Input Voltage	J1/2	gain=1	1		4.6	V
I_I	Input Bias Current						
V_{OL}	Lower Clamping Voltage	K1/2	$I_o=1ma$ referred to V_{REF}	-1.45		-1.22	V
V_{OH}	Higher Clamping Voltage						
V_{OS}	Input Offset Voltage	J1/2	referred to V_{REF} K1/2 J1/2 shorted			± 20	mV

CURRENT DECODER SECTION

V_{OS}	Output Offset Voltage	L1/2	N1/2=0 referred to V_{REF}			± 140	mV
R_{OUT}	Output Resistance						
V_{CLH}	Current Limit Threshold	O1/2 P1/2	referred to V_{REF}		± 0.5		V
V_{CDO}	Differential Output Offset Voltage	L1/2	$V_{off(+)} - V_{off(-)}$			± 20	mV

L6515

OSCILLATOR -PWM SECTIONS

Symbol	Parameter	Pin	Test Condition	Min.	Typ.	Max.	Unit
V _H	Upper Triangle Threshold		Referred to V _{REF}	+1.2		+1.8	V
V _L	Lower Triangle Threshold			-1.6		-1.3	V
I _{CD}	Charge/Discharge Current		I _{REF} =500μA	±160		±180	μA
V _O	PWM Output Voltage	O1/2	I _o =1.4mA			0.4	V
		P1/2		2.7			

DAC SECTION

I _{REF}	Current Reference Input Range	Z		0.3		0.7	mA
I _O	Sink and Source Output Current	J1/2	I _{REF} =0.5 mA	918	968	1018	μA
V _{REF}	Reference Voltage	Z	I _{REF} =20 μa	2.7	2.8	2.9	V
I _O	Linearity Error	J1/2	I _{REF} =0.5 mA			1.61	/FS

INPUT LOGIC SECTION

V _{INL}	Input IOw Voltage	R S T U V W X Y		-0.3		0.8	V
V _{INH}	Input High Voltage			2		7	V
I _L	Input					-10	μA
I _H	Input High Current High Voltage					30	μA

APPLICATION CIRCUIT

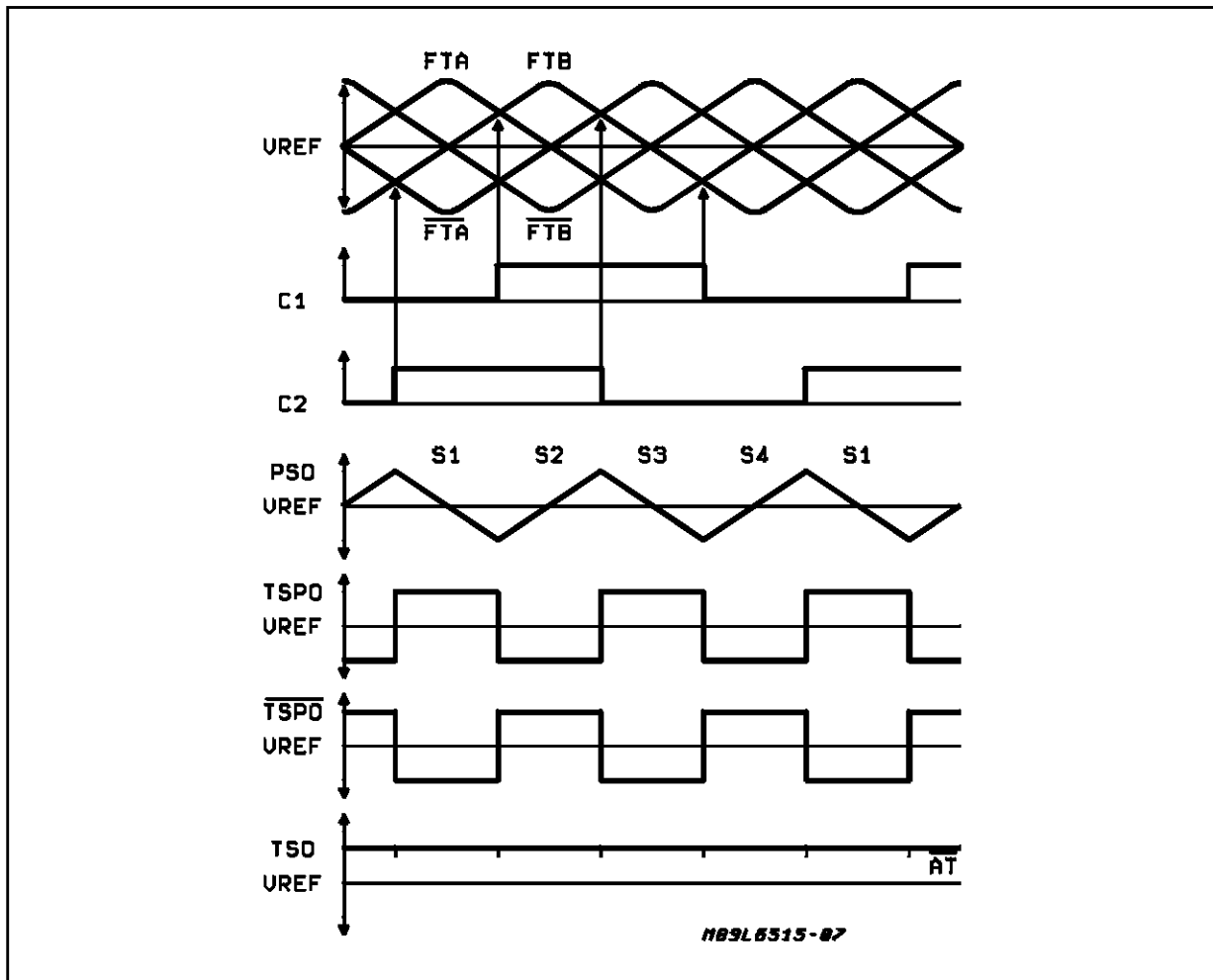

TRUTH TABLE TACHO-ENCODER LOGIC

INPUT SIGNAL

PDIB > PDIA	C 1 = HIGH
PDIB < PDIA	C 1 = LOW
PDIB > $\overline{\text{PDIA}}$	C2 = HIGH
PDIB < $\overline{\text{PDIA}}$	C2 = LOW

SWITCH SIGNAL

C1	C2	CLOSED	S2 POSITION
L	H	S1	TSP0
H	H	S2	$\overline{\text{TSP0}}$
H	L	S3	TSP0
L	L	S4	$\overline{\text{TSP0}}$

L6515

TRUTH TABLE LOGIC SELECTION CHIP ADDRESS

DECODER ADDRESS

Terminals		Functions
R	S	
L	L	NO ACTION
H	L	STROBE LATCH 1
L	H	STROBE LATCH 2
H	H	RESET LATCH 1/2

LATCH ADDRESS

TERMINALS						FUNCTIONS
T	U	V	W	X	Y	
H	L	L	L	L	L	Close S5 for positioning phase $\overline{D1/2}$
L	L	L	L	L	L	Close S6 for positioning phase $D1/2$
L	L	L	L	L	H	min current DAC out
L	H	H	H	H	H	max current DAC out
H	L	L	L	L	H	min current DAC out
H	H	H	H	H	H	max current DAC out

Output current source (J1/2)

Output current sink (J1/2)

DAC BITS

DIRECTION BITS

H91L6515-10

TIMING DIAGRAM OF COUNTER AND DIRECTION INDICATION LOGIC

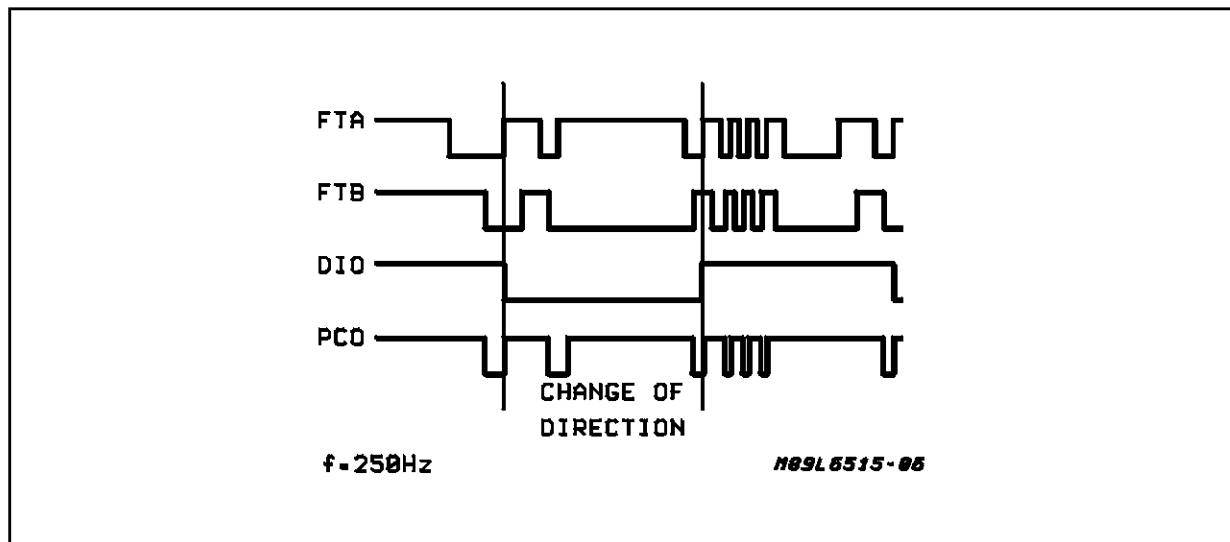

POSITION ENCODER

Main advantage of the operation principle of the positioning system is that a high performance position encoder is not required.

The system accepts several phases and amplitude errors of the encoder output signal without affecting the system performance.
Two position sensors are useful.

1) Optical-Encoder with IR-LED and Phototransistor

Figure 1.

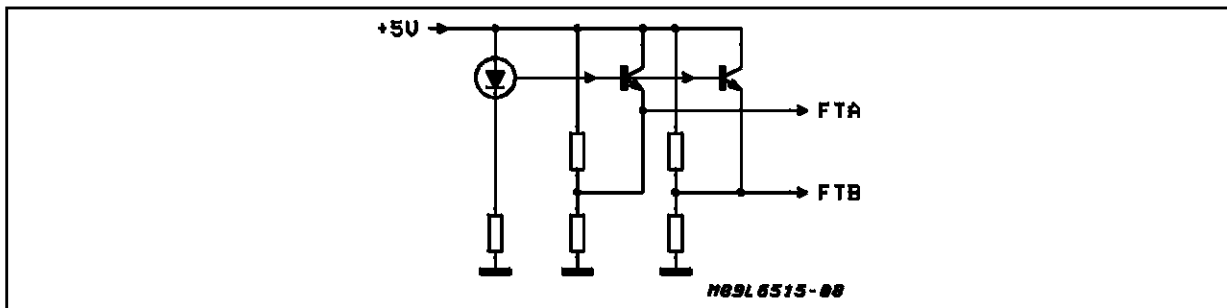

2) Magnetic Encoder with hall-effect sensors

Figure 2.

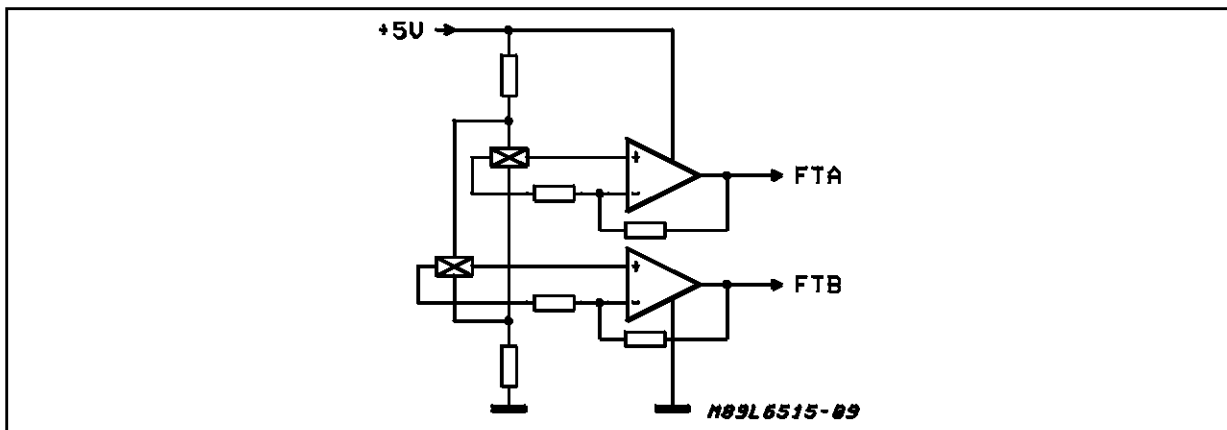

The allowed spread of the encoder output signal refer to reference level is shown in Fig.3.

Figure 3.

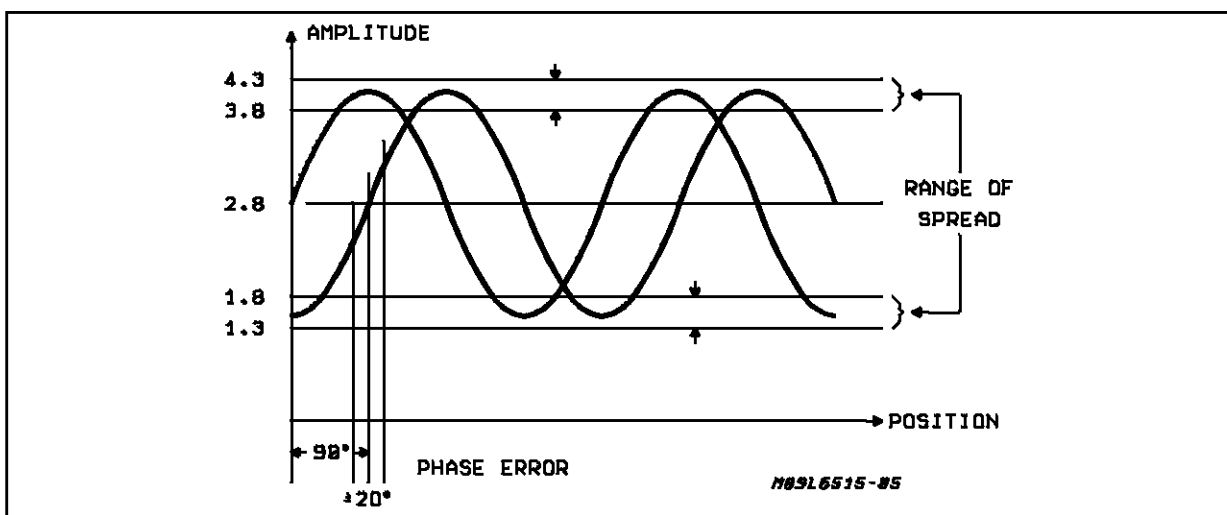

L6515

PLCC44 PACKAGE MECHANICAL DATA

DIM.	mm			inch		
	MIN.	TYP.	MAX.	MIN.	TYP.	MAX.
A	17.4		17.65	0.685		0.695
B	16.51		16.65	0.650		0.656
C	3.65		3.7	0.144		0.146
D	4.2		4.57	0.165		0.180
d1	2.59		2.74	0.102		0.108
d2		0.68			0.027	
E	14.99		16	0.590		0.630
e		1.27			0.050	
e3		12.7			0.500	
F		0.46			0.018	
F1		0.71			0.028	
G			0.101			0.004
M		1.16			0.046	
M1		1.14			0.045	

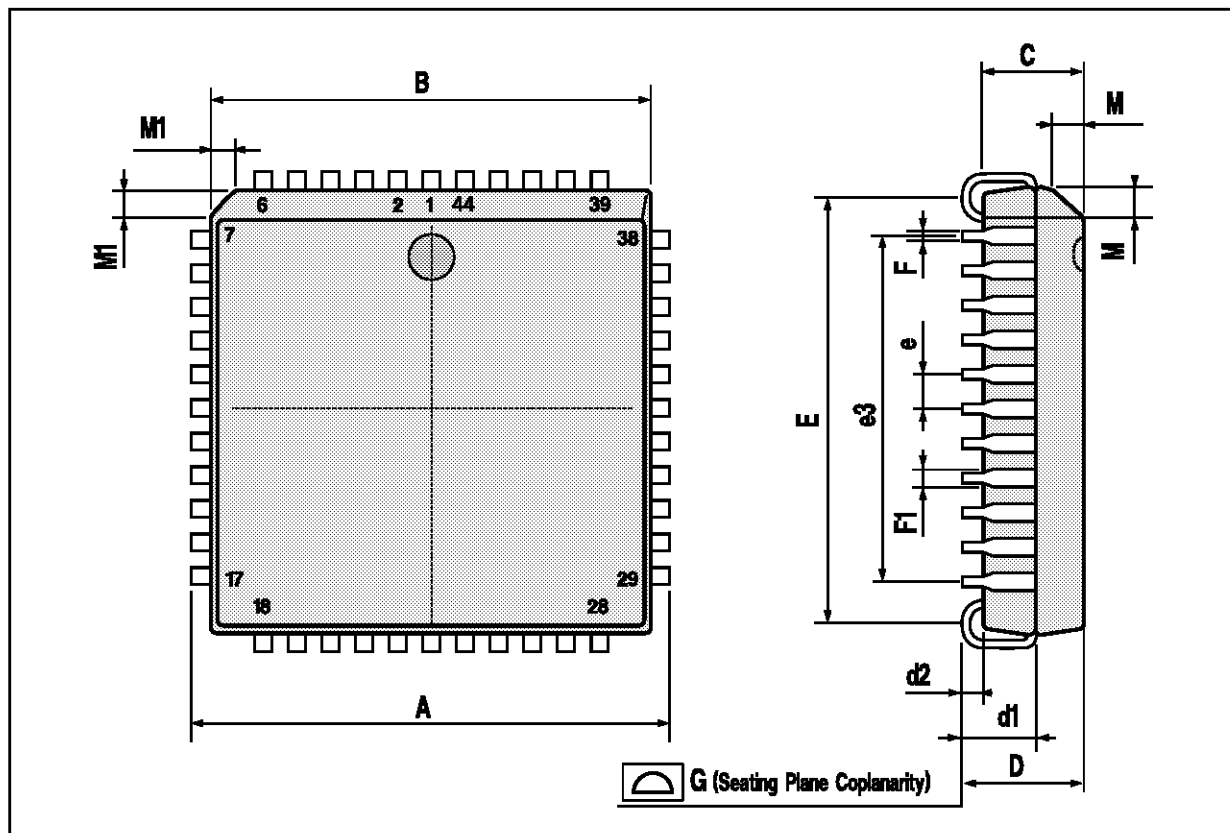

Information furnished is believed to be accurate and reliable. However, SGS-THOMSON Microelectronics assumes no responsibility for the consequences of use of such information nor for any infringement of patents or other rights of third parties which may result from its use. No license is granted by implication or otherwise under any patent or patent rights of SGS-THOMSON Microelectronics. Specifications mentioned in this publication are subject to change without notice. This publication supersedes and replaces all information previously supplied. SGS-THOMSON Microelectronics products are not authorized for use as critical components in life support devices or systems without express written approval of SGS-THOMSON Microelectronics.

© 1994 SGS-THOMSON Microelectronics - All Rights Reserved

SGS-THOMSON Microelectronics GROUP OF COMPANIES

Australia - Brazil - France - Germany - Hong Kong - Italy - Japan - Korea - Malaysia - Malta - Morocco - The Netherlands - Singapore - Spain - Sweden - Switzerland - Taiwan - Thailand - United Kingdom - U.S.A.