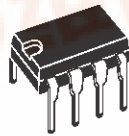




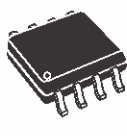
# L6571A L6571B

## HIGH VOLTAGE HALF BRIDGE DRIVER WITH OSCILLATOR

- TECHNOLOGY: BCD "OFF-LINE"
- FLOATING SUPPLY VOLTAGE UP TO 600V
- GND REFERRED SUPPLY VOLTAGE UP TO 18V
- DRIVER CURRENT CAPABILITY:
  - SINK CURRENT = 270mA
  - SOURCE CURRENT = 170mA
- VERY LOW START UP CURRENT: 150µA
- VERY LOW OPERATING CURRENT: <2mA
- UNDERVOLTAGE LOCKOUT
- PROGRAMMABLE OSCILLATOR FREQUENCY
- dV/dt IMMUNITY UP TO ± 50V/ns



**Minidip**



**SO8**

**ORDERING NUMBERS:**

L6571A	L6571AD
L6571B	L6571BD

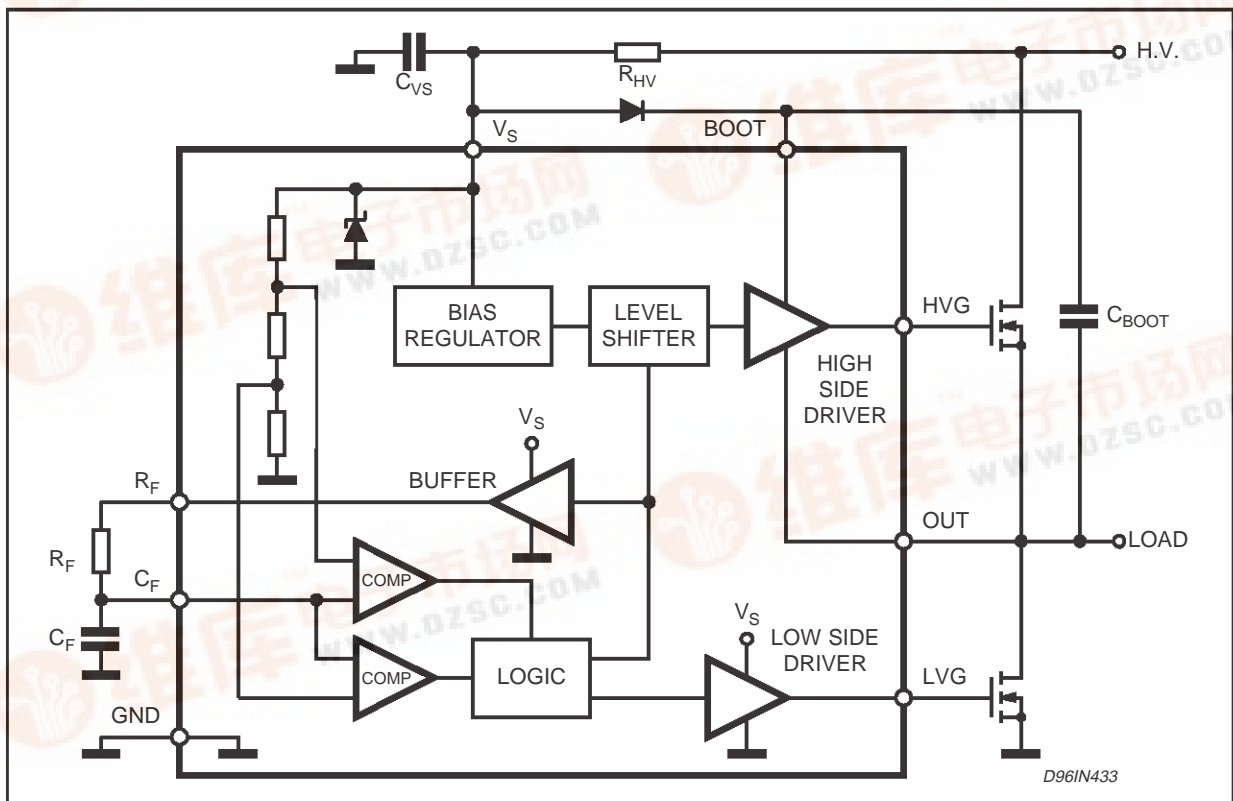
### DESCRIPTION

The device is a high voltage half bridge driver with built-in oscillator. The frequency of the oscillator can be programmed using external resistor

and capacitor.

The output drivers are designed to drive external n-channel power MOSFET and IGBT. The internal logic assures a minimum dead time to avoid cross-conduction of the power devices.

### BLOCK DIAGRAM



## L6571A - L6571B

### ABSOLUTE MAXIMUM RATINGS

Symbol	Parameter	Value	Unit
$I_S$ (*)	Supply Current	25	mA
$V_{CF}$	Oscillator Resistor Voltage	18	V
$V_{LVG}$	Low Side Switch Gate Output	14.6	V
$V_{OUT}$	High Side Switch Source Output	-1 to $V_{BOOT} - 18$	V
$V_{HVG}$	High Side Switch Gate Output	-1 to $V_{BOOT}$	V
$V_{BOOT}$	Floating Supply Voltage	618	V
$V_{BOOT/OUT}$	Floating Supply vs OUT Voltage	18	V
$dV_{BOOT}/dt$	$V_{BOOT}$ Slew Rate (Repetitive)	$\pm 50$	V/ns
$dV_{OUT}/dt$	$V_{OUT}$ Slew Rate (Repetitive)	$\pm 50$	V/ns
$T_{stg}$	Storage Temperature	-40 to 150	°C
$T_j$	Junction Temperature	-40 to 150	°C
$T_{amb}$	Ambient Temperature (Operative)	-40 to 125	°C

(\*) The device has an internal zener clamp between GND and  $V_S$  (typical 15.6V).  
Therefore the circuit should not be driven by a DC low impedance power source.

**Note:** ESD immunity for pins 6, 7 and 8 is guaranteed up to 900 V (Human Body Model)

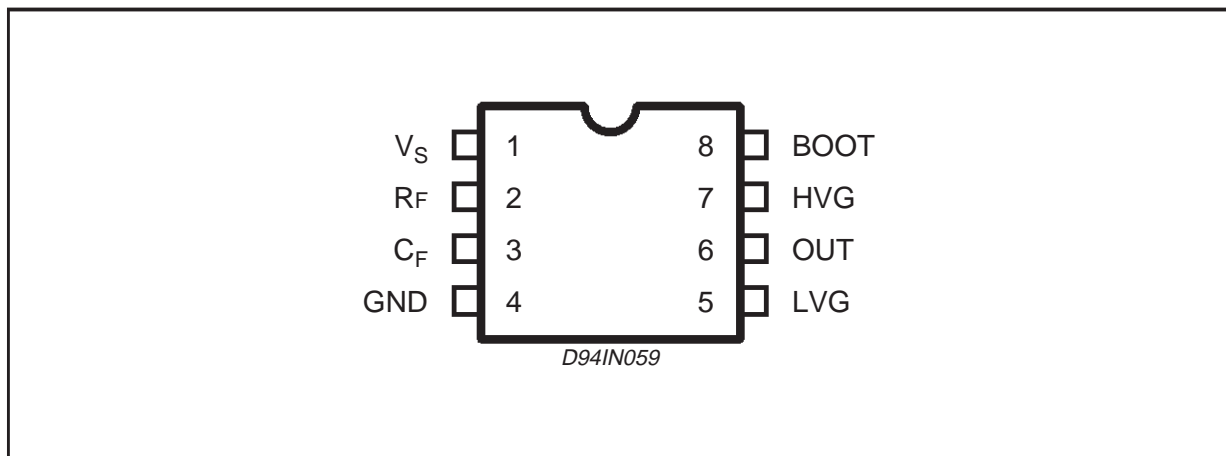
### THERMAL DATA

Symbol	Parameter	Minidip	SO8	Unit
$R_{th\ j-amb}$	Thermal Resistance Junction-Ambient	Max 100	150	°C/W

### RECOMMENDED OPERATING CONDITIONS

Symbol	Parameter	Min.	Max.	Unit
$V_S$	Supply Voltage	10	$V_{CL}$	V
$V_{BOOT}$	Floating Supply Voltage	-	500	V
$V_{OUT}$	High Side Switch Source Output	-1	$V_{BOOT} - V_{CL}$	V
$f_{out}$	Oscillation Frequency		200	kHz

### PIN CONNECTION



**ELECTRICAL CHARACTERISTICS** ( $V_S = 12V$ ;  $V_{BOOT} - V_{OUT} = 12V$ ;  $T_j = 25^\circ C$ ; unless otherwise specified.)

Symbol	Pin	Parameter	Test Condition	Min.	Typ.	Max.	Unit
$V_{SUVVP}$	1	$V_S$ Turn On Threshold		8.3	9	9.7	V
$V_{SUVN}$		$V_S$ Turn Off Threshold		7.3	8	8.7	V
$V_{SUVH}$		$V_S$ Hysteresis		0.7	1	1.3	V
$V_{CL}$		$V_S$ Clamping Voltage	$I_S = 5mA$	14.6	15.6	16.6	V
$I_{SU}$		Start Up Current	$V_S < V_{SUVN}$		150	250	$\mu A$
$I_q$		Quiescent Current	$V_S > V_{SUVVP}$		500	700	$\mu A$
$I_{BOOTLK}$		8	Leakage Current BOOT pin vs GND	$V_{BOOT} = 580V$			5
$I_{OUTLK}$	6	Leakage Current OUT pin vs GND	$V_{OUT} = 562V$			5	$\mu A$
$I_{HVG\ SO}$	7	High Side Driver Source Current	$V_{HVG} = 6V$	110	175		mA
$I_{HVG\ SI}$		High Side Driver Sink Current	$V_{HVG} = 6V$	190	275		mA
$I_{LVG\ SO}$	5	Low Side Driver Source Current	$V_{LVG} = 6V$	110	175		mA
$I_{LVG\ SI}$		Low Side Driver Sink Current	$V_{LVG} = 6V$	190	275		mA
$V_{RFON}$	2	RF High Level Output Voltage	$I_{RF} = 1mA$	$V_S - 0.05$		$V_S - 0.2$	V
$V_{RFOFF}$		RF Low Level Output Voltage	$I_{RF} = -1mA$	50		200	mV
$V_{CFU}$	3	CF Upper Threshold		7.7	7.95	8.2	V
$V_{CFL}$		CF Lower Threshold		3.80	4.05	4.3	V
$t_d$		Internal Dead Time	<b>L6571A</b> <b>L6571B</b>	0.85 0.50	1.25 0.72	1.65 0.94	$\mu s$ $\mu s$
$D_C$		Duty Cycle, Ratio Between Dead Time + Conduction Time of High Side and Low Side Drivers		0.45	0.5	0.55	
$I_{AVE}$	1	Average Current from $V_S$	No Load, $f_s = 60KHz$		1.2	1.5	mA
$f_{out}$	6	Oscillation Frequency	$R_T = 12k$ $C_T = 1nF$	57	60	63	kHz

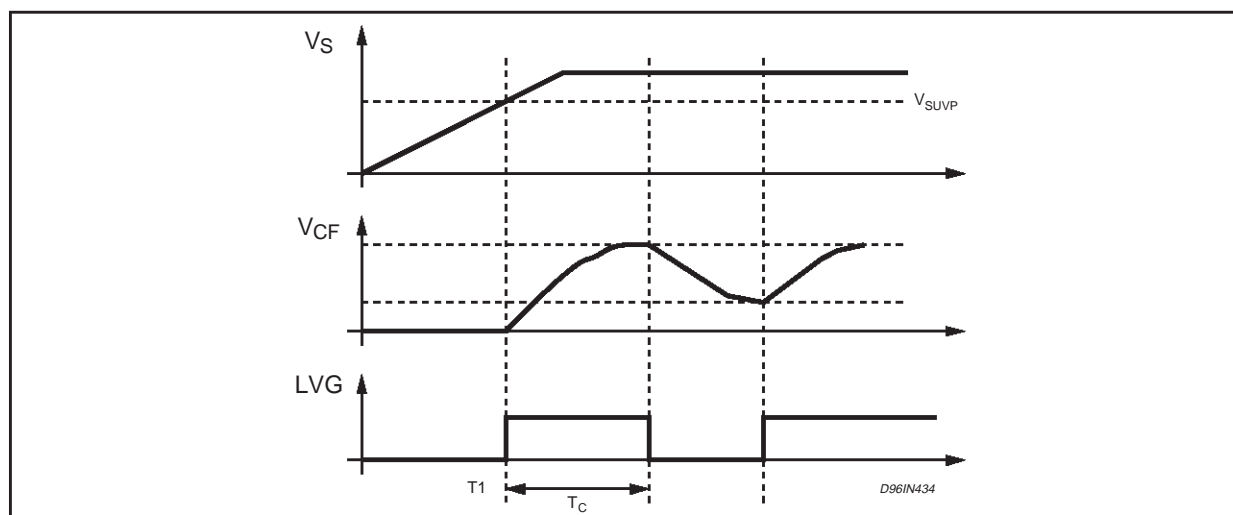
**OSCILLATOR FREQUENCY**

The frequency of the internal oscillator can be programmed using external resistor and capacitor. The nominal oscillator frequency can be calculated using the following equation:

$$f_{osc} = \frac{1}{2 \cdot R_F \cdot C_F \cdot \ln 2} = \frac{1}{1.3863 \cdot R_F \cdot C_F}$$

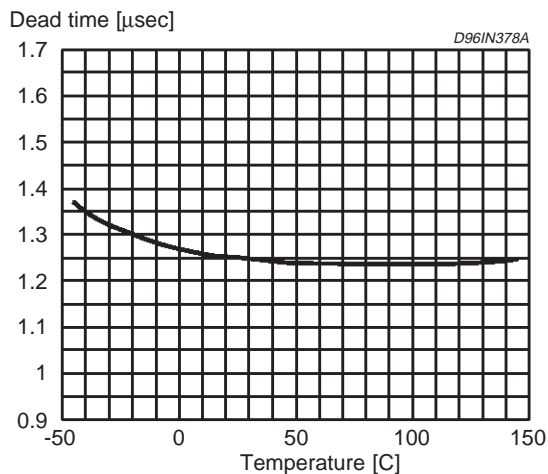
where  $R_F$  and  $C_F$  are the external resistor and capacitor

**Figure 2: WAVEFORMS**

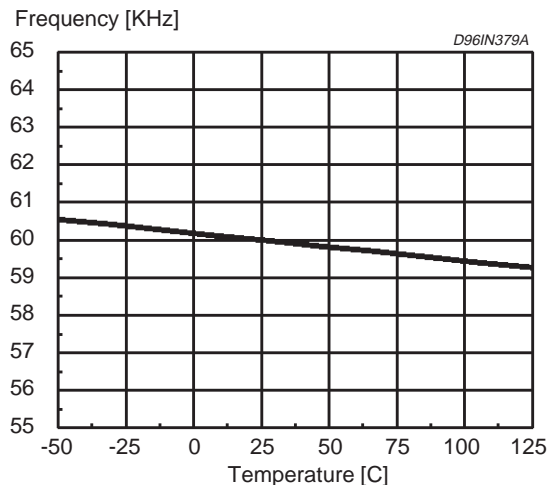


## L6571A - L6571B

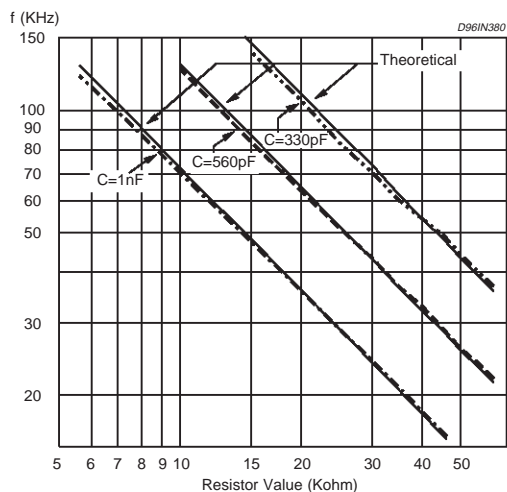
**Figure 3:** Typical Dead Time vs. Temperature Dependency (L6571A).



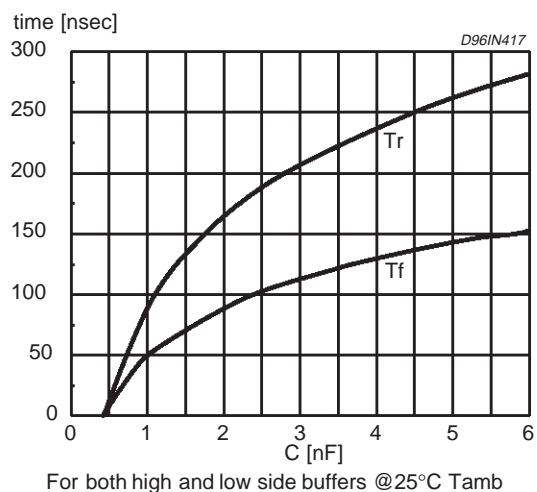
**Figure 4:** Typical Frequency vs Temperature Dependency



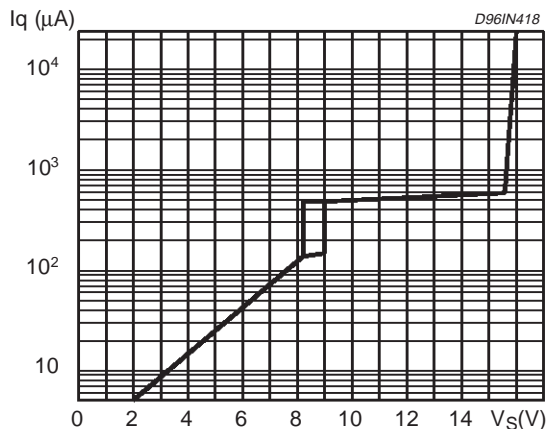
**Figure 5:** Typical and Theoretical Oscillator Frequency vs Resistor Value



**Figure 8:** Typical Rise and Fall Times vs. Load Capacitance

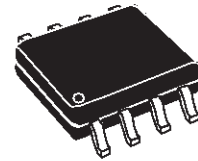


**Figure 9:** Quiescent Current vs. Supply Voltage.



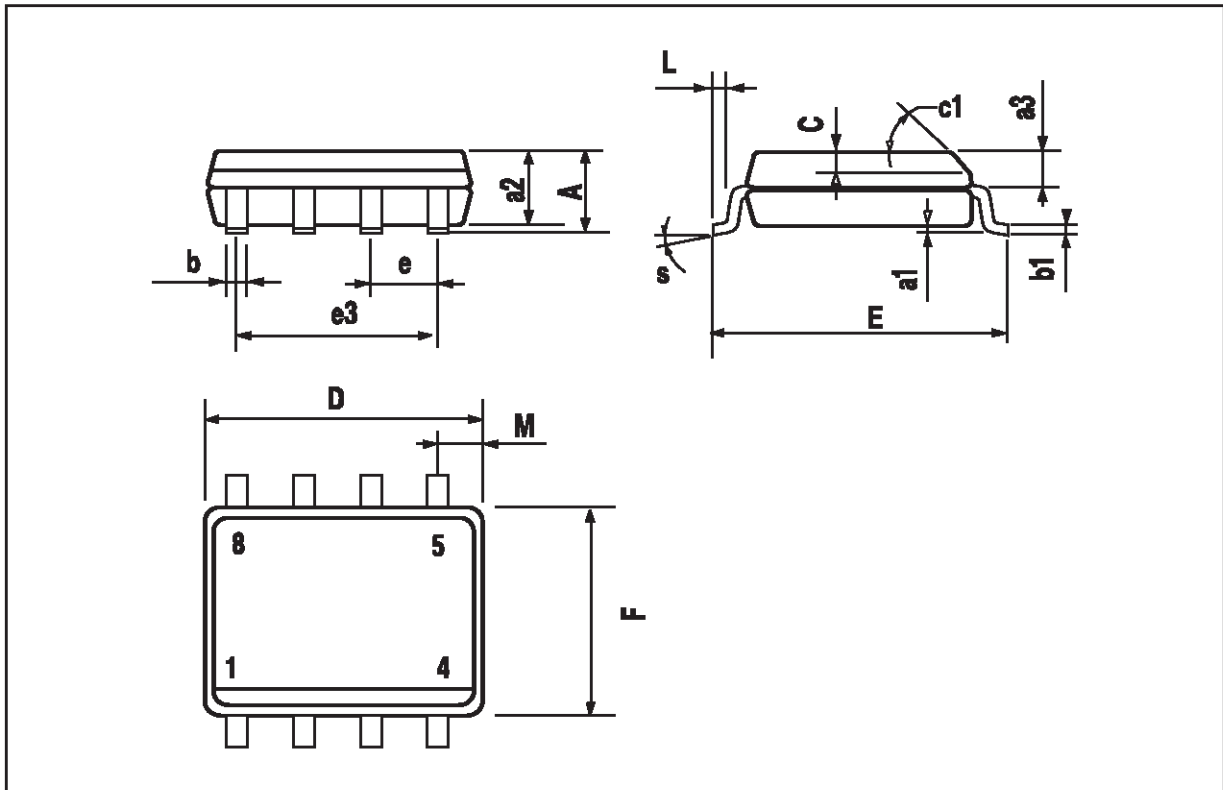
DIM.	mm			inch		
	MIN.	TYP.	MAX.	MIN.	TYP.	MAX.
A			1.75			0.069
a1	0.1		0.25	0.004		0.010
a2			1.65			0.065
a3	0.65		0.85	0.026		0.033
b	0.35		0.48	0.014		0.019
b1	0.19		0.25	0.007		0.010
C	0.25		0.5	0.010		0.020
c1	45° (typ.)					
D (1)	4.8		5.0	0.189		0.197
E	5.8		6.2	0.228		0.244
e		1.27			0.050	
e3		3.81			0.150	
F (1)	3.8		4.0	0.15		0.157
L	0.4		1.27	0.016		0.050
M			0.6			0.024
S	8° (max.)					

**OUTLINE AND MECHANICAL DATA**



**SO8**

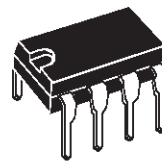
(1) D and F do not include mold flash or protrusions. Mold flash or protrusions shall not exceed 0.15mm (.006inch).



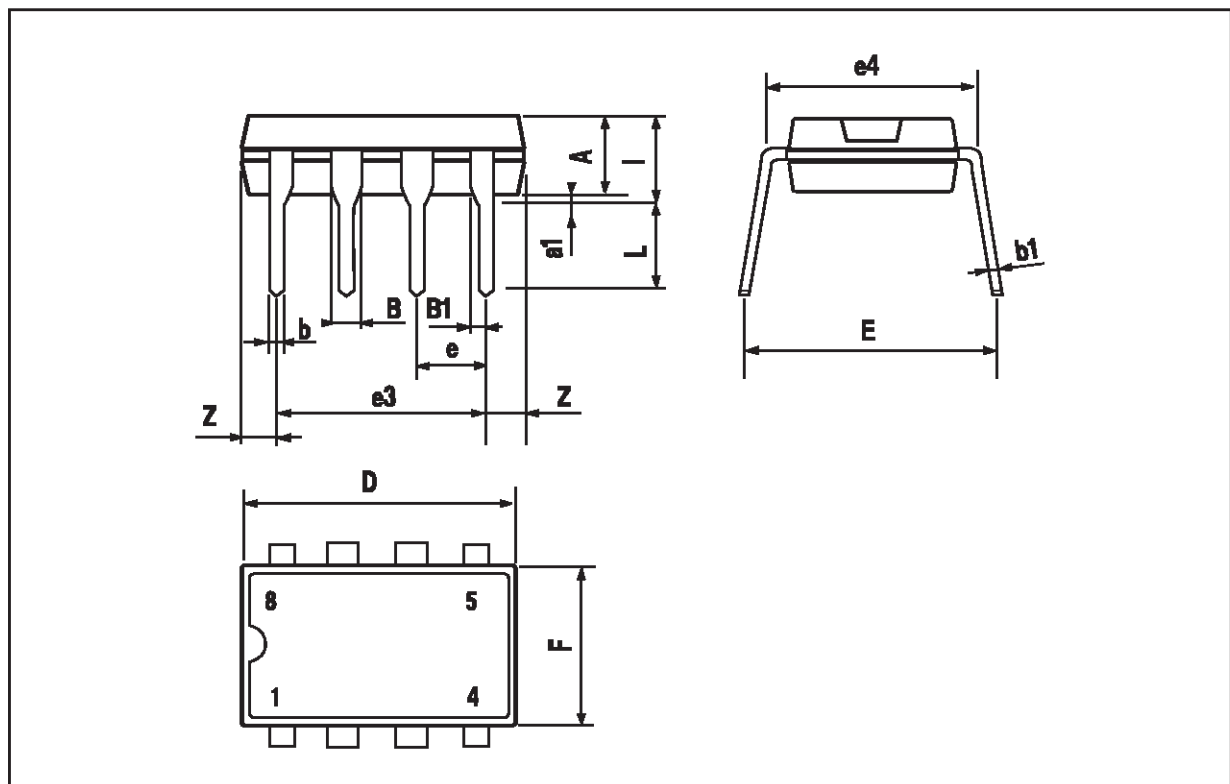
## L6571A - L6571B

DIM.	mm			inch		
	MIN.	TYP.	MAX.	MIN.	TYP.	MAX.
A		3.32			0.131	
a1	0.51			0.020		
B	1.15		1.65	0.045		0.065
b	0.356		0.55	0.014		0.022
b1	0.204		0.304	0.008		0.012
D			10.92			0.430
E	7.95		9.75	0.313		0.384
e		2.54			0.100	
e3		7.62			0.300	
e4		7.62			0.300	
F			6.6			0.260
I			5.08			0.200
L	3.18		3.81	0.125		0.150
Z			1.52			0.060

### OUTLINE AND MECHANICAL DATA



**Minidip**



Information furnished is believed to be accurate and reliable. However, STMicroelectronics assumes no responsibility for the consequences of use of such information nor for any infringement of patents or other rights of third parties which may result from its use. No license is granted by implication or otherwise under any patent or patent rights of STMicroelectronics. Specification mentioned in this publication are subject to change without notice. This publication supersedes and replaces all information previously supplied. STMicroelectronics products are not authorized for use as critical components in life support devices or systems without express written approval of STMicroelectronics.

The ST logo is a registered trademark of STMicroelectronics

© 2000 STMicroelectronics – Printed in Italy – All Rights Reserved

STMicroelectronics GROUP OF COMPANIES

Australia - Brazil - China - Finland - France - Germany - Hong Kong - India - Italy - Japan - Malaysia - Malta - Morocco -  
Singapore - Spain - Sweden - Switzerland - United Kingdom - U.S.A.

<http://www.st.com>