



L7900 SERIES

NEGATIVE VOLTAGE REGULATORS

- OUTPUT CURRENT UP TO 1.5 A
- OUTPUT VOLTAGES OF -5; -5.2; -6; -8; -9; -12; -15; -18; -20; -22; -24V
- THERMAL OVERLOAD PROTECTION
- SHORT CIRCUIT PROTECTION
- OUTPUT TRANSITION SOA PROTECTION

DESCRIPTION

The L7900 series of three-terminal negative regulators is available in TO-220, ISOWATT220 TO-3 and D²PAK packages and several fixed output voltages, making it useful in a wide range of applications. These regulators can provide local on-card regulation, eliminating the distribution problems associated with single point regulation; furthermore, having the same voltage option as the L7800 positive standard series, they are particularly suited for split power supplies. In addition, the -5.2V is also available for ECL system. If adequate heat sinking is provided, they can deliver over 1.5A output current. Although designed primarily as fixed voltage regulators, these devices can be used with external components to obtain adjustable voltages and currents.

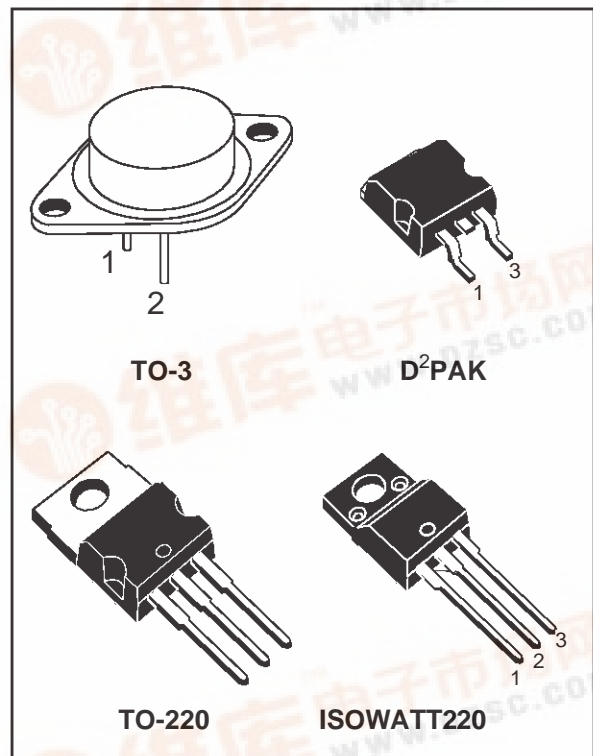

SCHEMATIC DIAGRAM

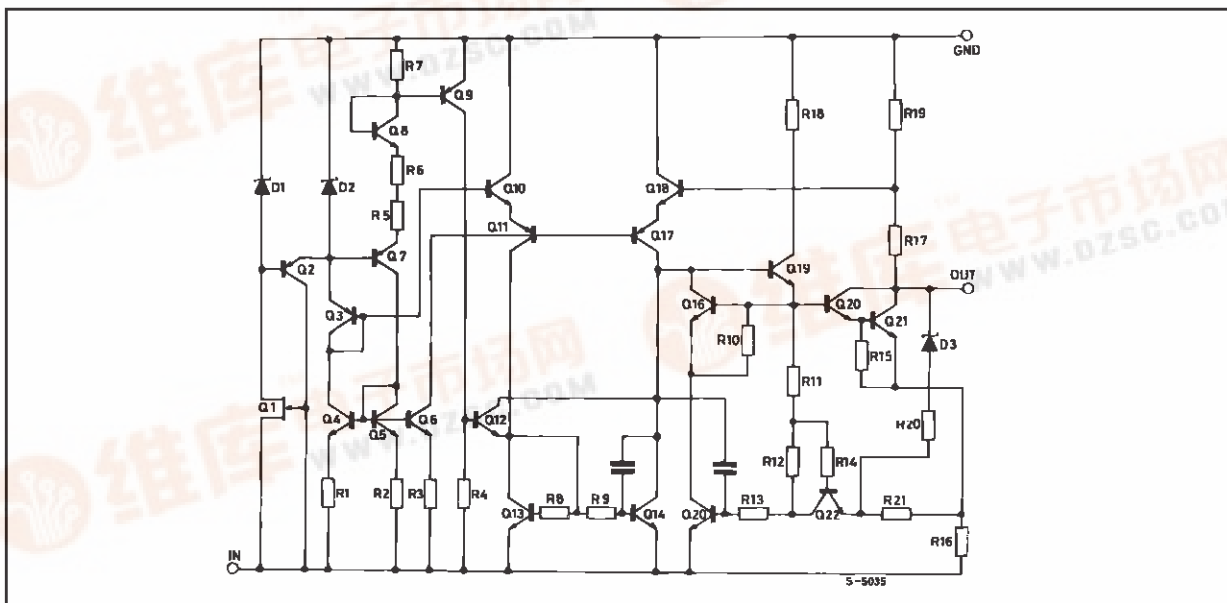

L7900

ABSOLUTE MAXIMUM RATINGS

Symbol	Parameter	Value	Unit
V_i	DC Input Voltage (for $V_o = 5$ to 18V) (for $V_o = 20, 24V$)	-35 -40	V
I_o	Output Current	Internally limited	
P_{tot}	Power Dissipation	Internally limited	
T_{op}	Operating Junction Temperature Range	0 to 150	°C
T_{stg}	Storage Temperature Range	- 65 to 150	°C

THERMAL DATA

Symbol	Parameter	D ² PAK	TO-220	ISOWATT220	TO-3	Unit
$R_{thj-case}$	Thermal Resistance Junction-case Max	3	3	4	4	°C/W
$R_{thj-amb}$	Thermal Resistance Junction-ambient Max	62.5	50	60	35	°C/W

CONNECTION DIAGRAM AND ORDERING NUMBERS (top view)

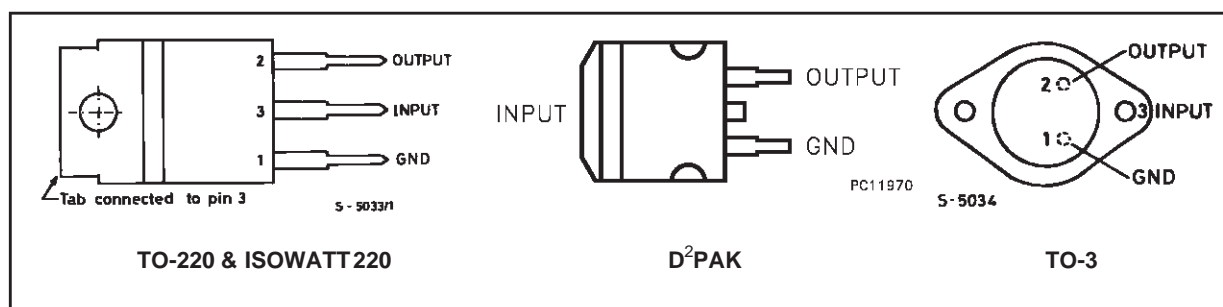

Type	TO-220	D ² PAK (*)	ISOWATT220	TO-3	Output Voltage
L7905C	L7905CV	L7905CD2T	L7905CP	L7905CT	-5V
L7952C	L7952CV	L7952CD2T		L7952CT	-5.2V
L7906C	L7906CV	L7906CD2T	L7906CP	L7906CT	-6V
L7908C	L7908CV	L7908CD2T	L7908CP	L7908CT	-8V
L7912C	L7912CV	L7912CD2T	L7912CP	L7912CT	-12V
L7915C	L7915CV	L7915CD2T	L7915CP	L7915CT	-15V
L7918C	L7918CV	L7918CD2T	L7918CP	L7918CT	-18V
L7920C	L7920CV	L7920CD2T	L7920CP	L7920CT	-20V
L7922C	L7922CV	L7922CD2T		L7922CT	-22V
L7924C	L7924CV	L7924CD2T	L7924CP	L7924CT	-24V

(*) AVAILABLE IN TAPE AND REEL WITH "-TR" SUFFIX

APPLICATION CIRCUIT

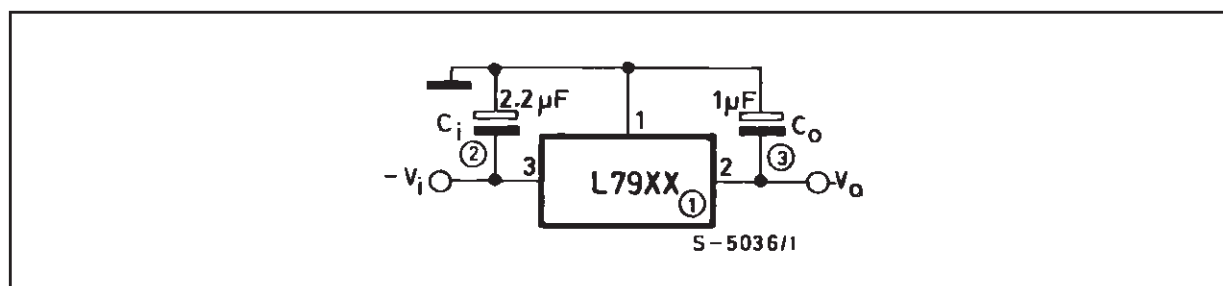

ELECTRICAL CHARACTERISTICS FOR L7905C (refer to the test circuits, $T_j = 0$ to $150\text{ }^\circ\text{C}$,
 $V_i = -10\text{V}$, $I_o = 500\text{ mA}$, $C_i = 2.2\text{ }\mu\text{F}$, $C_o = 1\text{ }\mu\text{F}$ unless otherwise specified)

Symbol	Parameter	Test Conditions	Min.	Typ.	Max.	Unit
V_o	Output Voltage	$T_j = 25\text{ }^\circ\text{C}$	-4.8	-5	-5.2	V
V_o	Output Voltage	$I_o = -5\text{ mA to } -1\text{ A}$ $P_o \leq 15\text{ W}$ $V_i = 8\text{ to } 20\text{ V}$	-4.75	-5	-5.25	V
ΔV_o^*	Line Regulation	$V_i = -7\text{ to } -25\text{ V}$ $T_j = 25\text{ }^\circ\text{C}$ $V_i = -8\text{ to } -12\text{ V}$ $T_j = 25\text{ }^\circ\text{C}$			100 50	mV mV
ΔV_o^*	Load Regulation	$I_o = 5\text{ to } 1500\text{ mA}$ $T_j = 25\text{ }^\circ\text{C}$ $I_o = 250\text{ to } 750\text{ mA}$ $T_j = 25\text{ }^\circ\text{C}$			100 50	mV mV
I_d	Quiescent Current	$T_j = 25\text{ }^\circ\text{C}$			3	mA
ΔI_d	Quiescent Current Change	$I_o = 5\text{ to } 1000\text{ mA}$			0.5	mA
ΔI_d	Quiescent Current Change	$V_i = -8\text{ to } -25\text{ V}$			1.3	mA
$\frac{\Delta V_o}{\Delta T}$	Output Voltage Drift	$I_o = 5\text{ mA}$		-0.4		mV/ $^\circ\text{C}$
e_N	Output Noise Voltage	$B = 10\text{Hz to } 100\text{kHz}$ $T_j = 25\text{ }^\circ\text{C}$		100		μV
SVR	Supply Voltage Rejection	$\Delta V_i = 10\text{ V}$ $f = 120\text{Hz}$	54	60		dB
V_d	Dropout Voltage	$I_o = 1\text{ A}$ $T_j = 25\text{ }^\circ\text{C}$ $\Delta V_o = 100\text{ mV}$		1.4		V
I_{sc}	Short Circuit Current			2.1		A
I_{scp}	Short Circuit Peak Current	$T_j = 25\text{ }^\circ\text{C}$		2.5		A

ELECTRICAL CHARACTERISTICS FOR L7952C (refer to the test circuits, $T_j = 0$ to $150\text{ }^\circ\text{C}$,
 $V_i = -10\text{V}$, $I_o = 500\text{ mA}$, $C_i = 2.2\text{ }\mu\text{F}$, $C_o = 1\text{ }\mu\text{F}$ unless otherwise specified)

Symbol	Parameter	Test Conditions	Min.	Typ.	Max.	Unit
V_o	Output Voltage	$T_j = 25\text{ }^\circ\text{C}$	-5.0	-5.2	-5.4	V
V_o	Output Voltage	$I_o = -5\text{ mA to } -1\text{ A}$ $P_o \leq 15\text{ W}$ $V_i = -9\text{ to } -21\text{ V}$	-4.95	-5.2	-5.45	V
ΔV_o^*	Line Regulation	$V_i = -8\text{ to } -25\text{ V}$ $T_j = 25\text{ }^\circ\text{C}$ $V_i = -9\text{ to } -12\text{ V}$ $T_j = 25\text{ }^\circ\text{C}$			105 52	mV mV
ΔV_o^*	Load Regulation	$I_o = 5\text{ to } 1500\text{ mA}$ $T_j = 25\text{ }^\circ\text{C}$ $I_o = 250\text{ to } 750\text{ mA}$ $T_j = 25\text{ }^\circ\text{C}$			105 52	mV mV
I_d	Quiescent Current	$T_j = 25\text{ }^\circ\text{C}$			3	mA
ΔI_d	Quiescent Current Change	$I_o = 5\text{ to } 1000\text{ mA}$			0.5	mA
ΔI_d	Quiescent Current Change	$V_i = -9\text{ to } -25\text{ V}$			1.3	mA
$\frac{\Delta V_o}{\Delta T}$	Output Voltage Drift	$I_o = 5\text{ mA}$		-0.5		mV/ $^\circ\text{C}$
e_N	Output Noise Voltage	$B = 10\text{Hz to } 100\text{kHz}$ $T_j = 25\text{ }^\circ\text{C}$		125		μV
SVR	Supply Voltage Rejection	$\Delta V_i = 10\text{ V}$ $f = 120\text{Hz}$	54	60		dB
V_d	Dropout Voltage	$I_o = 1\text{ A}$ $T_j = 25\text{ }^\circ\text{C}$ $\Delta V_o = 100\text{ mV}$		1.4		V
I_{sc}	Short Circuit Current			2		A
I_{scp}	Short Circuit Peak Current	$T_j = 25\text{ }^\circ\text{C}$		2.5		A

* Load and line regulation are specified at constant junction temperature. Changes in V_o due to heating effects must be taken into account separately. Pulse testing with low duty cycle is used.

L7900

ELECTRICAL CHARACTERISTICS FOR L7906C (refer to the test circuits, $T_j = 0$ to 150 °C, $V_i = -11V$, $I_o = 500$ mA, $C_i = 2.2$ μ F, $C_o = 1$ μ F unless otherwise specified)

Symbol	Parameter	Test Conditions	Min.	Typ.	Max.	Unit
V_o	Output Voltage	$T_j = 25$ °C	-5.75	-6	-6.25	V
V_o	Output Voltage	$I_o = -5$ mA to -1 A $P_o \leq 15$ W $V_i = -9.5$ to -21.5 V	-5.7	-6	-6.3	V
ΔV_o^*	Line Regulation	$V_i = -8.5$ to -25 V $T_j = 25$ °C $V_i = -9$ to -15 V $T_j = 25$ °C			120 60	mV mV
ΔV_o^*	Load Regulation	$I_o = 5$ to 1500 mA $T_j = 25$ °C $I_o = 250$ to 750 mA $T_j = 25$ °C			120 60	mV mV
I_d	Quiescent Current	$T_j = 25$ °C			3	mA
ΔI_d	Quiescent Current Change	$I_o = 5$ to 1000 mA			0.5	mA
ΔI_d	Quiescent Current Change	$V_i = -9.5$ to -25 V			1.3	mA
$\frac{\Delta V_o}{\Delta T}$	Output Voltage Drift	$I_o = 5$ mA		-0.6		mV/°C
e_N	Output Noise Voltage	$B = 10$ Hz to 100 KHz $T_j = 25$ °C		144		μ V
SVR	Supply Voltage Rejection	$\Delta V_i = 10$ V $f = 120$ Hz	54	60		dB
V_d	Dropout Voltage	$I_o = 1$ A $T_j = 25$ °C $\Delta V_o = 100$ mV		1.4		V
I_{sc}	Short Circuit Current			2		A
I_{scp}	Short Circuit Peak Current	$T_j = 25$ °C		2.5		A

ELECTRICAL CHARACTERISTICS FOR L7908C (refer to the test circuits, $T_j = 0$ to 150 °C, $V_i = -14V$, $I_o = 500$ mA, $C_i = 2.2$ μ F, $C_o = 1$ μ F unless otherwise specified)

Symbol	Parameter	Test Conditions	Min.	Typ.	Max.	Unit
V_o	Output Voltage	$T_j = 25$ °C	-7.7	-8	-8.3	V
V_o	Output Voltage	$I_o = -5$ mA to -1 A $P_o \leq 15$ W $V_i = -11.5$ to -23 V	-7.6	-8	-8.4	V
ΔV_o^*	Line Regulation	$V_i = -10.5$ to -25 V $T_j = 25$ °C $V_i = -11$ to -17 V $T_j = 25$ °C			160 80	mV mV
ΔV_o^*	Load Regulation	$I_o = 5$ to 1500 mA $T_j = 25$ °C $I_o = 250$ to 750 mA $T_j = 25$ °C			160 80	mV mV
I_d	Quiescent Current	$T_j = 25$ °C			3	mA
ΔI_d	Quiescent Current Change	$I_o = 5$ to 1000 mA			0.5	mA
ΔI_d	Quiescent Current Change	$V_i = -11.5$ to -25 V			1.3	mA
$\frac{\Delta V_o}{\Delta T}$	Output Voltage Drift	$I_o = 5$ mA		-0.6		mV/°C
e_N	Output Noise Voltage	$B = 10$ Hz to 100 KHz $T_j = 25$ °C		175		μ V
SVR	Supply Voltage Rejection	$\Delta V_i = 10$ V $f = 120$ Hz	54	60		dB
V_d	Dropout Voltage	$I_o = 1$ A $T_j = 25$ °C $\Delta V_o = 100$ mV		1.1		V
I_{sc}	Short Circuit Current			1.5		A
I_{scp}	Short Circuit Peak Current	$T_j = 25$ °C		2.5		A

* Load and line regulation are specified at constant junction temperature. Changes in V_o due to heating effects must be taken into account separately. Pulse testing with low duty cycle is used.

ELECTRICAL CHARACTERISTICS FOR L7912C (refer to the test circuits, $T_j = 0$ to 150 °C, $V_i = -19V$, $I_o = 500$ mA, $C_i = 2.2$ μ F, $C_o = 1$ μ F unless otherwise specified)

Symbol	Parameter	Test Conditions	Min.	Typ.	Max.	Unit
V_o	Output Voltage	$T_j = 25$ °C	-11.5	-12	-12.5	V
V_o	Output Voltage	$I_o = -5$ mA to -1 A $P_o \leq 15$ W $V_i = -15.5$ to -27 V	-11.4	-12	-12.6	V
ΔV_o^*	Line Regulation	$V_i = -14.5$ to -30 V $T_j = 25$ °C $V_i = -16$ to -22 V $T_j = 25$ °C			240 120	mV mV
ΔV_o^*	Load Regulation	$I_o = 5$ to 1500 mA $T_j = 25$ °C $I_o = 250$ to 750 mA $T_j = 25$ °C			240 120	mV mV
I_d	Quiescent Current	$T_j = 25$ °C			3	mA
ΔI_d	Quiescent Current Change	$I_o = 5$ to 1000 mA			0.5	mA
ΔI_d	Quiescent Current Change	$V_i = -15$ to -30 V			1	mA
$\frac{\Delta V_o}{\Delta T}$	Output Voltage Drift	$I_o = 5$ mA		-0.8		mV/°C
e_N	Output Noise Voltage	$B = 10$ Hz to 100 KHz $T_j = 25$ °C		200		μ V
SVR	Supply Voltage Rejection	$\Delta V_i = 10$ V $f = 120$ Hz	54	60		dB
V_d	Dropout Voltage	$I_o = 1$ A $T_j = 25$ °C $\Delta V_o = 100$ mV		1.1		V
I_{sc}	Short Circuit Current			1.5		A
I_{scp}	Short Circuit Peak Current	$T_j = 25$ °C		2.5		A

ELECTRICAL CHARACTERISTICS FOR L7915C (refer to the test circuits, $T_j = 0$ to 150 °C, $V_i = -23V$, $I_o = 500$ mA, $C_i = 2.2$ μ F, $C_o = 1$ μ F unless otherwise specified)

Symbol	Parameter	Test Conditions	Min.	Typ.	Max.	Unit
V_o	Output Voltage	$T_j = 25$ °C	-14.4	-15	-15.6	V
V_o	Output Voltage	$I_o = -5$ mA to -1 A $P_o \leq 15$ W $V_i = -18.5$ to -30 V	-14.3	-15	-15.7	V
ΔV_o^*	Line Regulation	$V_i = -17.5$ to -30 V $T_j = 25$ °C $V_i = -20$ to -26 V $T_j = 25$ °C			300 150	mV mV
ΔV_o^*	Load Regulation	$I_o = 5$ to 1500 mA $T_j = 25$ °C $I_o = 250$ to 750 mA $T_j = 25$ °C			300 150	mV mV
I_d	Quiescent Current	$T_j = 25$ °C			3	mA
ΔI_d	Quiescent Current Change	$I_o = 5$ to 1000 mA			0.5	mA
ΔI_d	Quiescent Current Change	$V_i = -18.5$ to -30 V			1	mA
$\frac{\Delta V_o}{\Delta T}$	Output Voltage Drift	$I_o = 5$ mA		-0.9		mV/°C
e_N	Output Noise Voltage	$B = 10$ Hz to 100 KHz $T_j = 25$ °C		250		μ V
SVR	Supply Voltage Rejection	$\Delta V_i = 10$ V $f = 120$ Hz	54	60		dB
V_d	Dropout Voltage	$I_o = 1$ A $T_j = 25$ °C $\Delta V_o = 100$ mV		1.1		V
I_{sc}	Short Circuit Current			1.3		A
I_{scp}	Short Circuit Peak Current	$T_j = 25$ °C		2.2		A

* Load and line regulation are specified at constant junction temperature. Changes in V_o due to heating effects must be taken into account separately. Pulse testing with low duty cycle is used.

L7900

ELECTRICAL CHARACTERISTICS FOR L7918C (refer to the test circuits, $T_j = 0$ to $150\text{ }^\circ\text{C}$,
 $V_i = -27\text{V}$, $I_o = 500\text{ mA}$, $C_i = 2.2\text{ }\mu\text{F}$, $C_o = 1\text{ }\mu\text{F}$ unless otherwise specified)

Symbol	Parameter	Test Conditions	Min.	Typ.	Max.	Unit
V_o	Output Voltage	$T_j = 25\text{ }^\circ\text{C}$	-17.3	-18	-18.7	V
V_o	Output Voltage	$I_o = -5\text{ mA to } -1\text{ A}$ $P_o \leq 15\text{ W}$ $V_i = -22\text{ to } -33\text{ V}$	-17.1	-18	-18.9	V
ΔV_o^*	Line Regulation	$V_i = -21\text{ to } -33\text{ V}$ $T_j = 25\text{ }^\circ\text{C}$ $V_i = -24\text{ to } -30\text{ V}$ $T_j = 25\text{ }^\circ\text{C}$			360 180	mV mV
ΔV_o^*	Load Regulation	$I_o = 5\text{ to } 1500\text{ mA}$ $T_j = 25\text{ }^\circ\text{C}$ $I_o = 250\text{ to } 750\text{ mA}$ $T_j = 25\text{ }^\circ\text{C}$			360 180	mV mV
I_d	Quiescent Current	$T_j = 25\text{ }^\circ\text{C}$			3	mA
ΔI_d	Quiescent Current Change	$I_o = 5\text{ to } 1000\text{ mA}$			0.5	mA
ΔI_d	Quiescent Current Change	$V_i = -22\text{ to } -33\text{ V}$			1	mA
$\frac{\Delta V_o}{\Delta T}$	Output Voltage Drift	$I_o = 5\text{ mA}$		-1		mV/ $^\circ\text{C}$
e_N	Output Noise Voltage	$B = 10\text{Hz to } 100\text{kHz}$ $T_j = 25\text{ }^\circ\text{C}$		300		μV
SVR	Supply Voltage Rejection	$\Delta V_i = 10\text{ V}$ $f = 120\text{ Hz}$	54	60		dB
V_d	Dropout Voltage	$I_o = 1\text{ A}$ $T_j = 25\text{ }^\circ\text{C}$ $\Delta V_o = 100\text{ mV}$		1.1		V
I_{sc}	Short Circuit Current			1.1		A
I_{scp}	Short Circuit Peak Current	$T_j = 25\text{ }^\circ\text{C}$		2.2		A

ELECTRICAL CHARACTERISTICS FOR L7920C (refer to the test circuits, $T_j = 0$ to $150\text{ }^\circ\text{C}$,
 $V_i = -29\text{V}$, $I_o = 500\text{ mA}$, $C_i = 2.2\text{ }\mu\text{F}$, $C_o = 1\text{ }\mu\text{F}$ unless otherwise specified)

Symbol	Parameter	Test Conditions	Min.	Typ.	Max.	Unit
V_o	Output Voltage	$T_j = 25\text{ }^\circ\text{C}$	-19.2	-20	-20.8	V
V_o	Output Voltage	$I_o = -5\text{ mA to } -1\text{ A}$ $P_o \leq 15\text{ W}$ $V_i = -24\text{ to } -35\text{ V}$	-19	-20	-21	V
ΔV_o^*	Line Regulation	$V_i = -23\text{ to } -35\text{ V}$ $T_j = 25\text{ }^\circ\text{C}$ $V_i = -26\text{ to } -32\text{ V}$ $T_j = 25\text{ }^\circ\text{C}$			400 200	mV mV
ΔV_o^*	Load Regulation	$I_o = 5\text{ to } 1500\text{ mA}$ $T_j = 25\text{ }^\circ\text{C}$ $I_o = 250\text{ to } 750\text{ mA}$ $T_j = 25\text{ }^\circ\text{C}$			400 200	mV mV
I_d	Quiescent Current	$T_j = 25\text{ }^\circ\text{C}$			3	mA
ΔI_d	Quiescent Current Change	$I_o = 5\text{ to } 1000\text{ mA}$			0.5	mA
ΔI_d	Quiescent Current Change	$V_i = -24\text{ to } -35\text{ V}$			1	mA
$\frac{\Delta V_o}{\Delta T}$	Output Voltage Drift	$I_o = 5\text{ mA}$		-1.1		mV/ $^\circ\text{C}$
e_N	Output Noise Voltage	$B = 10\text{Hz to } 100\text{kHz}$ $T_j = 25\text{ }^\circ\text{C}$		350		μV
SVR	Supply Voltage Rejection	$\Delta V_i = 10\text{ V}$ $f = 120\text{ Hz}$	54	60		dB
V_d	Dropout Voltage	$I_o = 1\text{ A}$ $T_j = 25\text{ }^\circ\text{C}$ $\Delta V_o = 100\text{ mV}$		1.1		V
I_{sc}	Short Circuit Current			0.9		A
I_{scp}	Short Circuit Peak Current	$T_j = 25\text{ }^\circ\text{C}$		2.5		A

* Load and line regulation are specified at constant junction temperature. Changes in V_o due to heating effects must be taken into account separately. Pulse testing with low duty cycle is used.

ELECTRICAL CHARACTERISTICS FOR L7922C (refer to the test circuits, $T_j = 0$ to 150 °C,
 $V_i = -31$ V, $I_o = 500$ mA, $C_i = 2.2$ μ F, $C_o = 1$ μ F unless otherwise specified)

Symbol	Parameter	Test Conditions	Min.	Typ.	Max.	Unit
V_o	Output Voltage	$T_j = 25$ °C	-21.1	-22	-22.9	V
V_o	Output Voltage	$I_o = -5$ mA to -1 A $P_o \leq 15$ W $V_i = -26$ to -37 V	-20.9	-22	-23.1	V
ΔV_o^*	Line Regulation	$V_i = -25$ to -37 V $T_j = 25$ °C $V_i = -28$ to -34 V $T_j = 25$ °C			440 220	mV mV
ΔV_o^*	Load Regulation	$I_o = 5$ to 1500 mA $T_j = 25$ °C $I_o = 250$ to 750 mA $T_j = 25$ °C			440 220	mV mV
I_d	Quiescent Current	$T_j = 25$ °C			3	mA
ΔI_d	Quiescent Current Change	$I_o = 5$ to 1000 mA			0.5	mA
ΔI_d	Quiescent Current Change	$V_i = -26$ to -37 V			1	mA
$\frac{\Delta V_o}{\Delta T}$	Output Voltage Drift	$I_o = 5$ mA		-1.1		mV/°C
e_N	Output Noise Voltage	$B = 10$ Hz to 100 KHz $T_j = 25$ °C		375		μ V
SVR	Supply Voltage Rejection	$\Delta V_i = 10$ V $f = 120$ Hz	54	60		dB
V_d	Dropout Voltage	$I_o = 1$ A $T_j = 25$ °C $\Delta V_o = 100$ mV		1.1		V
I_{sc}	Short Circuit Current			1.1		A
I_{scp}	Short Circuit Peak Current	$T_j = 25$ °C		2.2		A

ELECTRICAL CHARACTERISTICS FOR L7924C (refer to the test circuits, $T_j = 0$ to 150 °C,
 $V_i = -33$ V, $I_o = 500$ mA, $C_i = 2.2$ μ F, $C_o = 1$ μ F unless otherwise specified)

Symbol	Parameter	Test Conditions	Min.	Typ.	Max.	Unit
V_o	Output Voltage	$T_j = 25$ °C	-23	-24	-25	V
V_o	Output Voltage	$I_o = -5$ mA to -1 A $P_o \leq 15$ W $V_i = -27$ to -38 V	-22.8	-24	-25.2	V
ΔV_o^*	Line Regulation	$V_i = -27$ to -38 V $T_j = 25$ °C $V_i = -30$ to -36 V $T_j = 25$ °C			480 240	mV mV
ΔV_o^*	Load Regulation	$I_o = 5$ to 1500 mA $T_j = 25$ °C $I_o = 250$ to 750 mA $T_j = 25$ °C			480 240	mV mV
I_d	Quiescent Current	$T_j = 25$ °C			3	mA
ΔI_d	Quiescent Current Change	$I_o = 5$ to 1000 mA			0.5	mA
ΔI_d	Quiescent Current Change	$V_i = -27$ to -38 V			1	mA
$\frac{\Delta V_o}{\Delta T}$	Output Voltage Drift	$I_o = 5$ mA		-1		mV/°C
e_N	Output Noise Voltage	$B = 10$ Hz to 100 KHz $T_j = 25$ °C		400		μ V
SVR	Supply Voltage Rejection	$\Delta V_i = 10$ V $f = 120$ Hz	54	60		dB
V_d	Dropout Voltage	$I_o = 1$ A $T_j = 25$ °C $\Delta V_o = 100$ mV		1.1		V
I_{sc}	Short Circuit Current			1.1		A
I_{scp}	Short Circuit Peak Current	$T_j = 25$ °C		2.2		A

* Load and line regulation are specified at constant junction temperature. Changes in V_o due to heating effects must be taken into account separately. Pulse testing with low duty cycle is used.

APPLICATION INFORMATION

Figure 1 : Fixed Output Regulator.

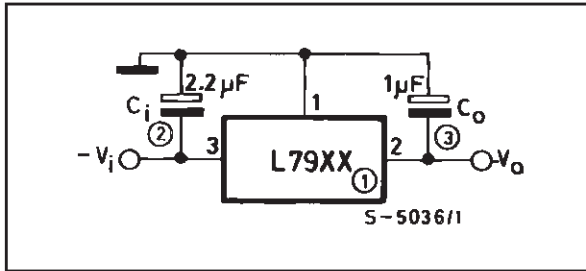

Notes :

1. To specify an output voltage, substitute voltage value for "XX".
2. Required for stability. For value given, capacitor must be solid tantalum. If aluminium electrolytics are used, at least ten times value should be selected. C₁ is required if regulator is located an appreciable distance from power supply filter.
3. To improve transient response. If large capacitors are used, a high current diode from input to output (1N4001 or similar) should be introduced to protect the device from momentary input short circuit.

Figure 2 : Split Power Supply (± 15V/1A).

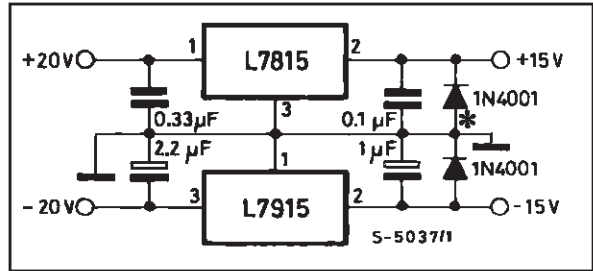

Against potential latch-up problems.

Figure 3 : Circuit for Increasing Output Voltage.

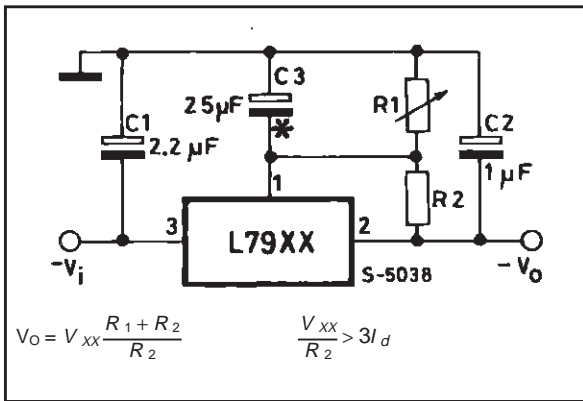

C3 Optional for improved transient response and ripple rejection.

Figure 4 : High Current Negative Regulator (- 5V/4A with 5A current limiting).

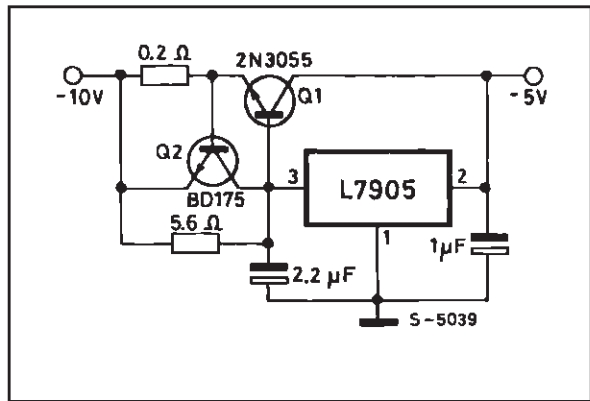
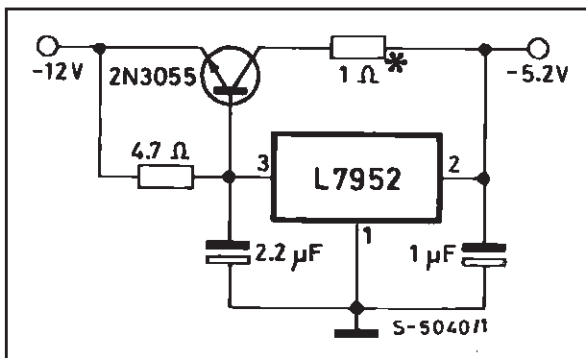

Figure 5 : Typical ECL System Power Supply (- 5.2V/4A).



Optional dropping resistor to reduce the power dissipated in the boost transistor.

TO-3 (R) MECHANICAL DATA

DIM.	mm			inch		
	MIN.	TYP.	MAX.	MIN.	TYP.	MAX.
A		11.7			0.460	
B	0.96		1.10	0.037		0.043
C			1.70			0.066
D			8.7			0.342
E			20.0			0.787
G		10.9			0.429	
N		16.9			0.665	
P			26.2			1.031
R	3.88		4.09	0.152		0.161
U			39.50			1.555
V		30.10			1.185	

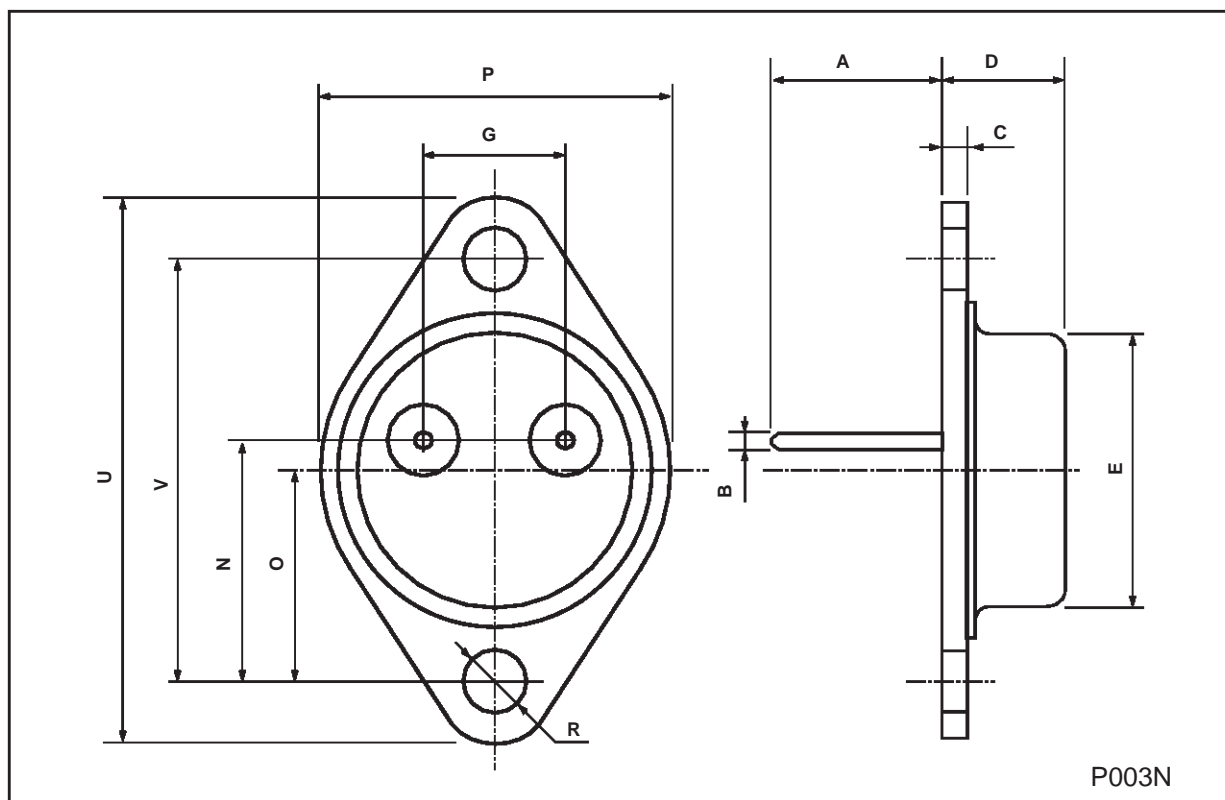

P003N

TO-220 MECHANICAL DATA

DIM.	mm			inch		
	MIN.	TYP.	MAX.	MIN.	TYP.	MAX.
A			4.8			0.189
C			1.37			0.054
D	2.4		2.8	0.094		0.110
D1	1.2		1.35	0.047		0.053
E	0.35		0.55	0.014		0.022
F	0.61		0.94	0.024		0.037
F2	1.15		1.4	0.045		0.055
G	4.95	5.08	5.21	0.195	0.200	0.205
H2			10.4			0.409
H3	10.05		10.4	0.396		0.409
L2		16.2			0.638	
L3	26.3	26.7	27.1	1.035	1.051	1.067
L5	2.6		3	0.102		0.118
L6	15.1		15.8	0.594		0.622
L7	6		6.6	0.236		0.260
Dia.	3.65		3.85	0.144		0.152

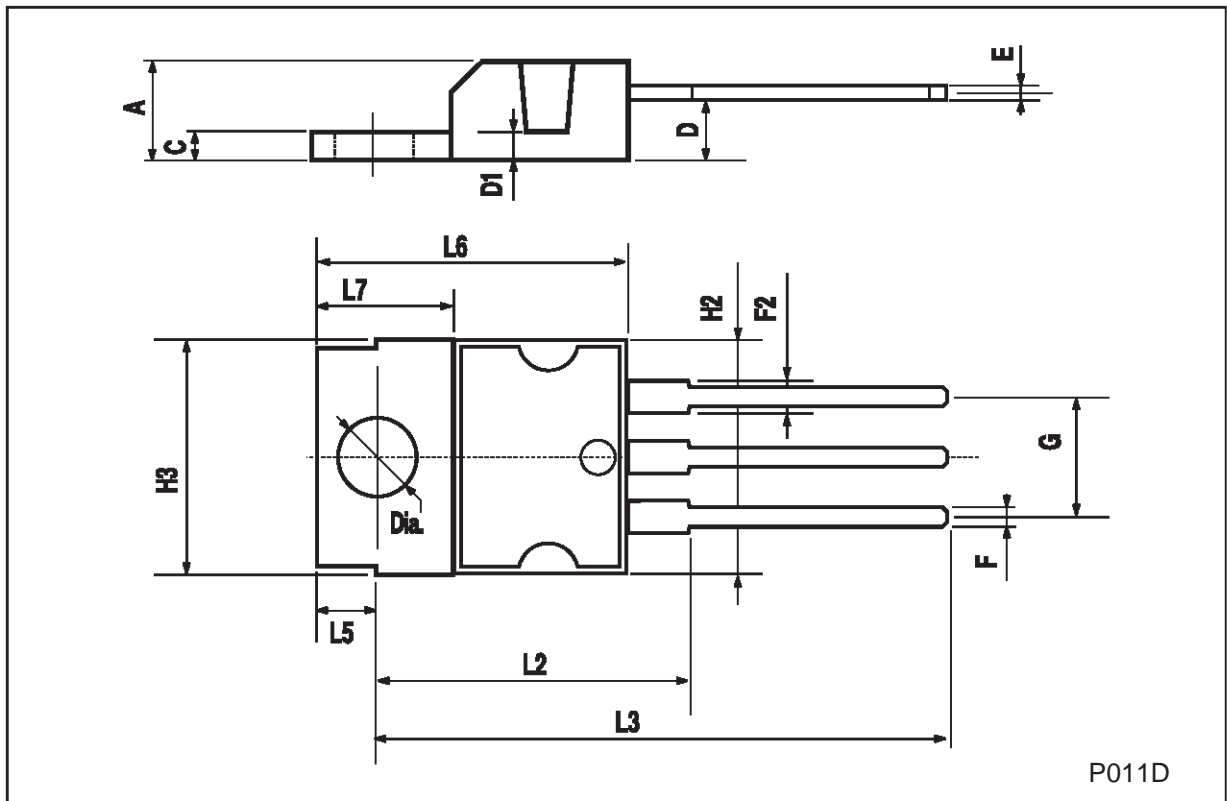

ISOWATT220 MECHANICAL DATA

DIM.	mm			inch		
	MIN.	TYP.	MAX.	MIN.	TYP.	MAX.
A	4.4		4.6	0.173		0.181
B	2.5		2.7	0.098		0.106
D	2.5		2.75	0.098		0.108
E	0.4		0.7	0.015		0.027
F	0.75		1	0.030		0.039
F1	1.15		1.7	0.045		0.067
F2	1.15		1.7	0.045		0.067
G	4.95		5.2	0.195		0.204
G1	2.4		2.7	0.094		0.106
H	10		10.4	0.393		0.409
L2		16			0.630	
L3	28.6		30.6	1.126		1.204
L4	9.8		10.6	0.385		0.417
L6	15.9		16.4	0.626		0.645
L7	9		9.3	0.354		0.366
∅	3		3.2	0.118		0.126

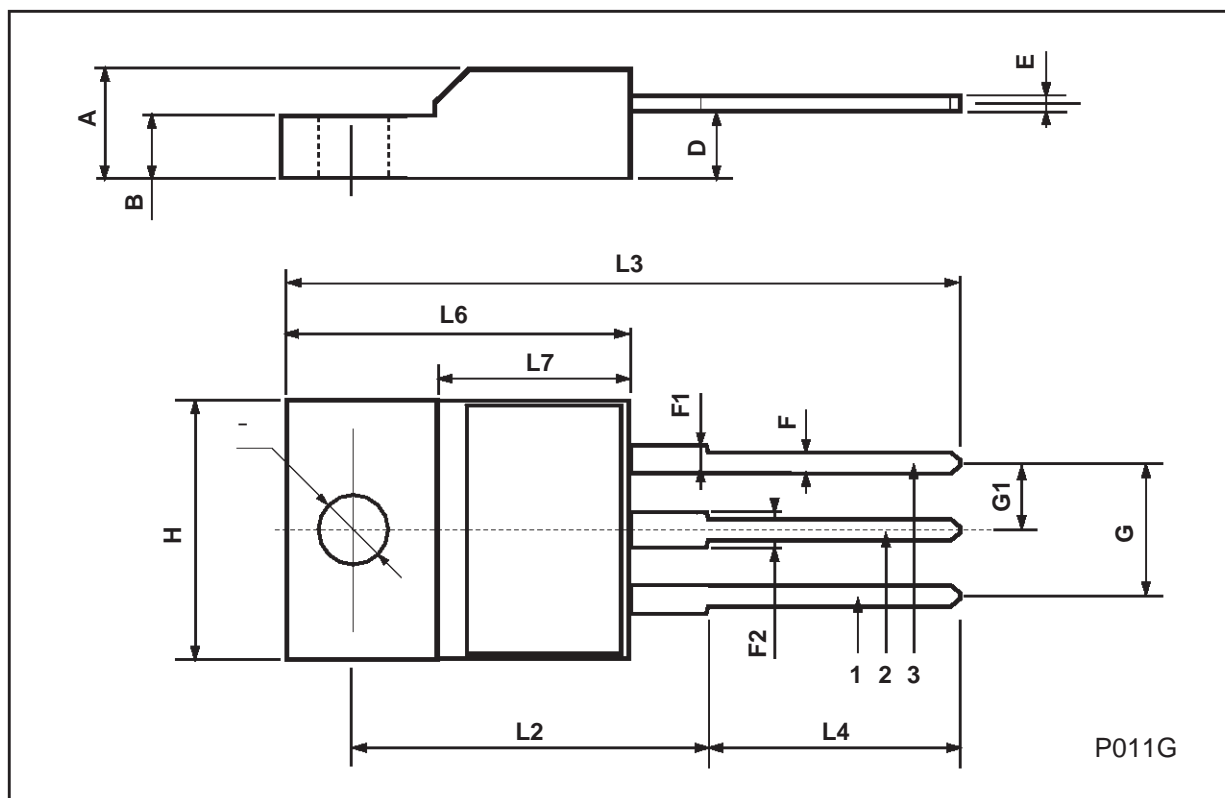

TO-263 (D²PAK) MECHANICAL DATA

DIM.	mm			inch		
	MIN.	TYP.	MAX.	MIN.	TYP.	MAX.
A	4.4		4.6	0.173		0.181
A1	2.49		2.69	0.098		0.106
B	0.7		0.93	0.027		0.036
B2	1.14		1.7	0.044		0.067
C	0.45		0.6	0.017		0.023
C2	1.23		1.36	0.048		0.053
D	8.95		9.35	0.352		0.368
E	10		10.4	0.393		0.409
G	4.88		5.28	0.192		0.208
L	15		15.85	0.590		0.624
L2	1.27		1.4	0.050		0.055
L3	1.4		1.75	0.055		0.068

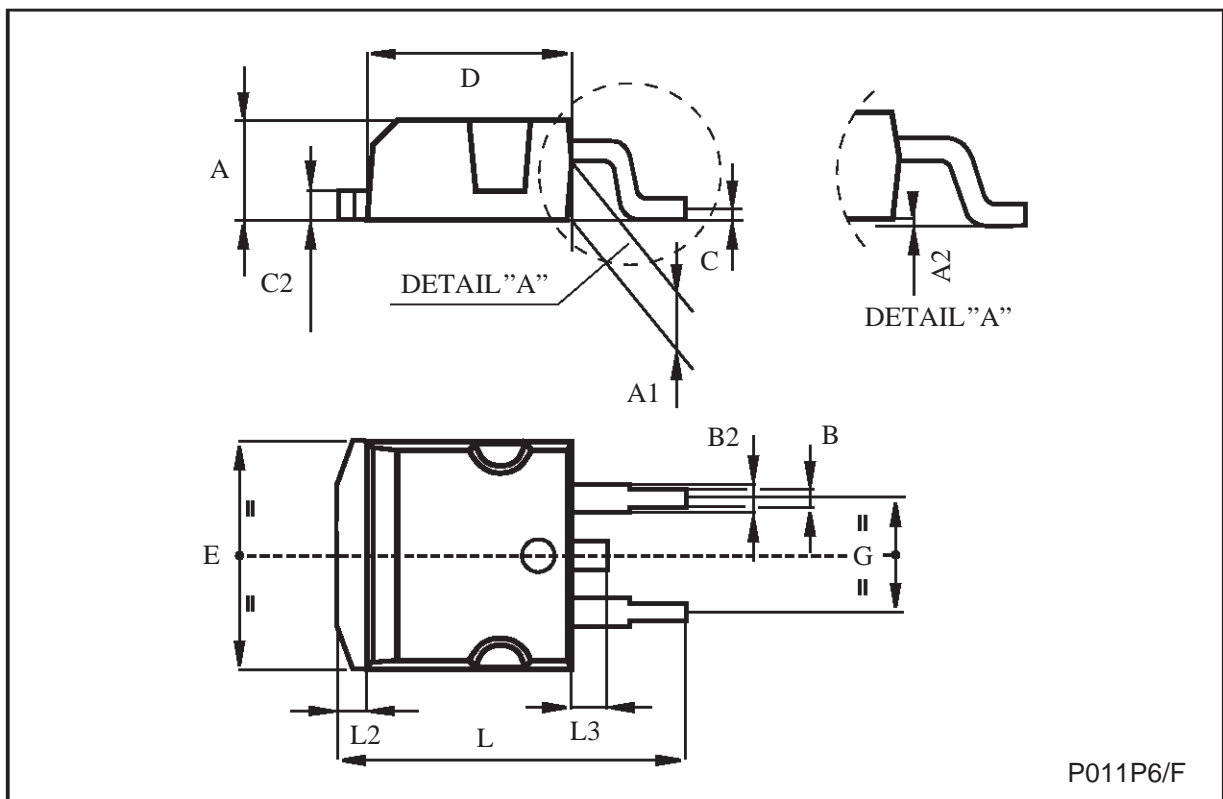

Information furnished is believed to be accurate and reliable. However, STMicroelectronics assumes no responsibility for the consequences of use of such information nor for any infringement of patents or other rights of third parties which may result from its use. No license is granted by implication or otherwise under any patent or patent rights of STMicroelectronics. Specification mentioned in this publication are subject to change without notice. This publication supersedes and replaces all information previously supplied. STMicroelectronics products are not authorized for use as critical components in life support devices or systems without express written approval of STMicroelectronics.

The ST logo is a registered trademark of STMicroelectronics

© 1999 STMicroelectronics – Printed in Italy – All Rights Reserved
STMicroelectronics GROUP OF COMPANIES

Australia - Brazil - China - Finland - France - Germany - Hong Kong - India - Italy - Japan - Malaysia - Malta - Morocco
Singapore - Spain - Sweden - Switzerland - United Kingdom - U.S.A.

<http://www.st.com>