

**24A, 800V Stealth™ Diode**

The ISL9R2480G2 is a Stealth™ diode optimized for low loss performance in high frequency applications. The Stealth family exhibits low reverse recovery current ( $I_{RRM}$ ) and exceptionally soft recovery under typical operating conditions.

This device is intended for use as a free wheeling or boost diode in power supplies and other power switching applications. The low  $I_{RRM}$  and short  $t_a$  phase reduce loss in switching transistors. The soft recovery minimizes ringing, expanding the range of conditions under which the diode may be operated without the use of additional snubber circuitry.

Formerly developmental type TA49392.

**Ordering Information**

PART NUMBER	PACKAGE	BRAND
ISL9R2480G2	TO-247	R2480G2

NOTE: When ordering, use the entire part number.

**Symbol**



**Features**

- Soft Recovery. . . . .  $t_b / t_a > 1.2$
- Fast Recovery . . . . .  $t_{rr} < 35ns$
- Operating Temperature . . . . . 175°C
- Reverse Voltage . . . . . 800V

**Applications**

- Switch Mode Power Supplies
- PFC Boost Diode
- UPS Free Wheeling Diode
- Motor Drive FWD
- SMPS FWD
- Snubber Diode

**Packaging**

JEDEC STYLE 2 LEAD TO-247

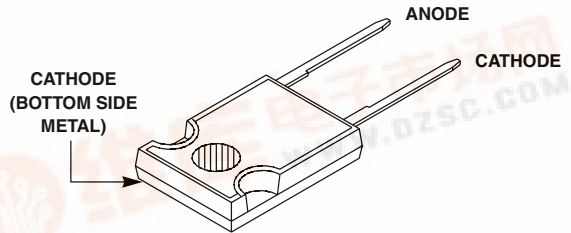

**Absolute Maximum Ratings**  $T_C = 25^\circ C$ , Unless Otherwise Specified

			UNITS
Peak Repetitive Reverse Voltage . . . . .	$V_{RRM}$	800	V
Working Peak Reverse Voltage . . . . .	$V_{RWM}$	800	V
DC Blocking Voltage . . . . .	$V_R$	800	V
Average Rectified Forward Current . . . . .	$I_{F(AV)}$	24	A
Repetitive Peak Surge Current . . . . . (Square Wave, 20kHz)	$I_{FRM}$	48	A
Nonrepetitive Peak Surge Current . . . . . (Halfwave 1 Phase 60Hz)	$I_{FSM}$	240	A
Maximum Power Dissipation . . . . .	$P_D$	160	W
Operating and Storage Temperature . . . . .	$T_{STG}, T_J$	-55 to 175	°C



## ISL9R2480G2

### Electrical Specifications $T_C = 25^\circ\text{C}$ , Unless Otherwise Specified

SYMBOL	TEST CONDITION	MIN	TYP	MAX	UNITS
BV	$I_R = 1\text{mA}$	800	-	-	V
$V_F$	$I_F = 24\text{A}$	-	2.5	3.0	V
	$I_F = 24\text{A}, T_C = 125^\circ\text{C}$	-	2.0	2.5	V
$I_R$	$V_R = 600\text{V}$	-	-	100	$\mu\text{A}$
	$V_R = 600\text{V}, T_C = 125^\circ\text{C}$	-	-	1.0	mA
$t_{rr}$	$I_F = 1\text{A}, di_F/dt = 100\text{A}/\mu\text{s}, V_R = 30\text{V}$	-	27	35	ns
	$I_F = 24\text{A}, di_F/dt = 100\text{A}/\mu\text{s}, V_R = 30\text{V}$	-	34	45	ns
$t_{rr}$	$I_F = 24\text{A}, di_F/dt = 200\text{A}/\mu\text{s}, V_R = 520\text{V}, T_C = 25^\circ\text{C}$	-	35	-	ns
$I_{RRM}$		-	4.2	-	A
$Q_{RR}$		-	75	-	nC
$t_{rr}$	$I_F = 24\text{A}, di_F/dt = 200\text{A}/\mu\text{s}, V_R = 520\text{V}, T_C = 125^\circ\text{C}$	-	145	-	ns
S		-	3.8	-	
$I_{RRM}$		-	5.0	-	A
$Q_{RR}$		-	500	-	nC
$t_{rr}$	$I_F = 24\text{A}, di_F/dt = 900\text{A}/\mu\text{s}, V_R = 520\text{V}, T_C = 125^\circ\text{C}$	-	72	-	ns
S		-	1.96	-	
$I_{RRM}$		-	17.3	-	A
$Q_{RR}$		-	710	-	nC
$di_M/dt$		-	600	-	$\text{A}/\mu\text{s}$
$C_J$	$V_R = 10\text{V}, I_F = 0\text{A}$	-	95	-	pF
$R_{\theta JC}$		-	-	0.92	$^\circ\text{C}/\text{W}$

#### DEFINITIONS

BV = Breakdown Voltage.

$V_F$  = Instantaneous forward voltage ( $pw = 300\mu\text{s}, D = 2\%$ ).

$I_R$  = Instantaneous reverse current.

$t_{rr}$  = Reverse recovery time ( $t_a + t_b$ ).

$I_{RRM}$  = Maximum reverse recovery current.

$Q_{RR}$  = Reverse recovery charge.

S = Softness factor ( $t_b / t_a$ ).

$di_M/dt$  = Maximum di/dt during  $t_b$ .

$C_J$  = Junction Capacitance.

$R_{\theta JC}$  = Thermal resistance junction to case.

$pw$  = pulse width.

D = Duty cycle

## ISL9R2480G2

### TO-247

2 LEAD JEDEC STYLE TO-247 PLASTIC PACKAGE (FOR RECTIFIERS ONLY)

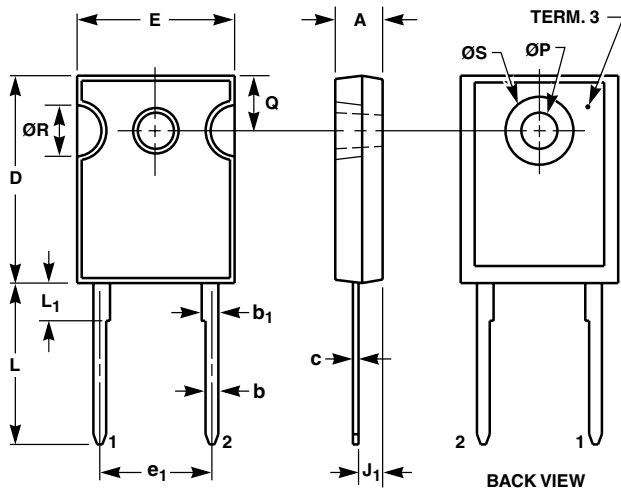

SYMBOL	INCHES		MILLIMETERS		NOTES
	MIN	MAX	MIN	MAX	
A	0.180	0.190	4.58	4.82	-
b	0.046	0.051	1.17	1.29	2, 3
b <sub>1</sub>	0.060	0.070	1.53	1.77	1, 2
c	0.020	0.026	0.51	0.66	1, 2, 3
D	0.800	0.820	20.32	20.82	-
E	0.605	0.625	15.37	15.87	-
e <sub>1</sub>	0.438 BSC		11.12 BSC		4
J <sub>1</sub>	0.090	0.105	2.29	2.66	5
L	0.620	0.640	15.75	16.25	-
L <sub>1</sub>	0.145	0.155	3.69	3.93	1
ØP	0.138	0.144	3.51	3.65	-
Q	0.210	0.220	5.34	5.58	-
ØR	0.195	0.205	4.96	5.20	-
ØS	0.260	0.270	6.61	6.85	-

**NOTES:**

1. Lead dimension and finish uncontrolled in L<sub>1</sub>.
2. Lead dimension (without solder).
3. Add typically 0.002 inches (0.05mm) for solder coating.
4. Position of lead to be measured 0.250 inches (6.35mm) from bottom of dimension D.
5. Position of lead to be measured 0.100 inches (2.54mm) from bottom of dimension D.
6. Controlling dimension: Inch.
7. Revision 2 dated 12-93.

## TRADEMARKS

The following are registered and unregistered trademarks Fairchild Semiconductor owns or is authorized to use and is not intended to be an exhaustive list of all such trademarks.

ACE <sup>x</sup> ™	FAST <sup>®</sup>	PACMAN™	SuperSOT™-3
Bottomless™	FAST <sup>r</sup> ™	POP™	SuperSOT™-6
CoolFET™	GlobalOptoisolator™	PowerTrench <sup>®</sup>	SuperSOT™-8
CROSSVOLT™	GTO™	QFET™	SyncFET™
DenseTrench™	HiSeC™	QS™	TinyLogic™
DOMESTM	ISOPLANAR™	QT Optoelectronics™	UHC™
EcoSPARK™	LittleFET™	Quiet Series™	UltraFET™
E <sup>2</sup> CMOSTM	MicroFET™	SILENT SWITCHER <sup>®</sup>	VCX™
EnSigna™	MICROWIRE™	SMART START™	
FACT™	OPTOLOGIC™	Star* Power™	
FACT Quiet Series™	OPTOPLANAR™	Stealth™	

## DISCLAIMER

FAIRCHILD SEMICONDUCTOR RESERVES THE RIGHT TO MAKE CHANGES WITHOUT FURTHER NOTICE TO ANY PRODUCTS HEREIN TO IMPROVE RELIABILITY, FUNCTION OR DESIGN. FAIRCHILD DOES NOT ASSUME ANY LIABILITY ARISING OUT OF THE APPLICATION OR USE OF ANY PRODUCT OR CIRCUIT DESCRIBED HEREIN; NEITHER DOES IT CONVEY ANY LICENSE UNDER ITS PATENT RIGHTS, NOR THE RIGHTS OF OTHERS.

## LIFE SUPPORT POLICY

FAIRCHILD'S PRODUCTS ARE NOT AUTHORIZED FOR USE AS CRITICAL COMPONENTS IN LIFE SUPPORT DEVICES OR SYSTEMS WITHOUT THE EXPRESS WRITTEN APPROVAL OF FAIRCHILD SEMICONDUCTOR CORPORATION. As used herein:

1. Life support devices or systems are devices or systems which, (a) are intended for surgical implant into the body, or (b) support or sustain life, or (c) whose failure to perform when properly used in accordance with instructions for use provided in the labeling, can be reasonably expected to result in significant injury to the user.
2. A critical component is any component of a life support device or system whose failure to perform can be reasonably expected to cause the failure of the life support device or system, or to affect its safety or effectiveness.

## PRODUCT STATUS DEFINITIONS

### Definition of Terms

Datasheet Identification	Product Status	Definition
Advance Information	Formative or In Design	This datasheet contains the design specifications for product development. Specifications may change in any manner without notice.
Preliminary	First Production	This datasheet contains preliminary data, and supplementary data will be published at a later date. Fairchild Semiconductor reserves the right to make changes at any time without notice in order to improve design.
No Identification Needed	Full Production	This datasheet contains final specifications. Fairchild Semiconductor reserves the right to make changes at any time without notice in order to improve design.
Obsolete	Not In Production	This datasheet contains specifications on a product that has been discontinued by Fairchild semiconductor. The datasheet is printed for reference information only.