



AM Tuner for Car Radio

Overview

The LA1130 is an IC developed for AM tuner systems in car radio applications. It provides low-level local oscillation so that it can be applied in varactor diode tuning applications as well as μ tuning applications.

Functions

- RF amplification
- MIX
- OSC (with ALC)
- IF amplification
- Detection
- AGC (normal)
- RF wide-band AGC
- Others

Features

- Good space factor due to single-end package.
- Easy to design printed circuit pattern due to 3mm-pitch pin interval.
- Double-balanced type MIX : Improvement in IF interference, spurious interference.
- Normal AGC : Less variation in detector output to input.
- RF wide-band AGC : Improvement in cross modulation distortion, especially strong input characteristics in varactor diode tuning applications because of low operating level (300mVrms).
- AGC drive output for FET : Possible to apply AGC to FET at input stage in varactor diode tuning applications.
- ALC at OSC stage : Improvement in tracking error due to stabilized low-level (350mVrms) oscillation output in varactor diode tuning applications.
- Reference voltage output : Possible to use 5.6V reference voltage for other bias (FET, etc.).
- VCC variation compensation : Less variation in gain, distortion, etc. (7.5 to 16V)
- Less ripple voltage : Less modulation of carrier by supply voltage ripple.
- Low pop noise : Possible to reduce pop noise at the time of VCC-on, mode-on by selecting AGC time constant.

Package Dimensions

unit: mm

3020A-SIP16

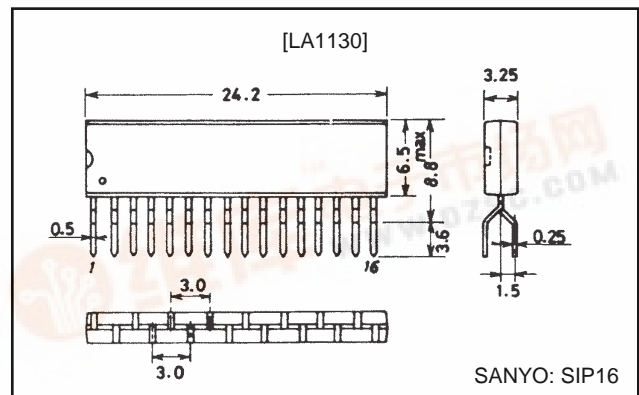

Equivalent Circuit Block Diagram

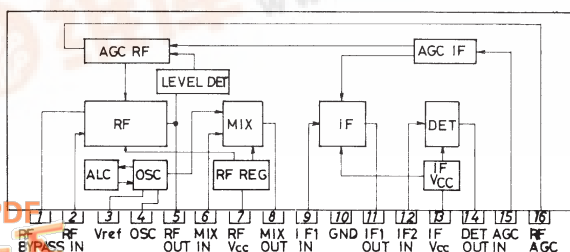

LA1130

Specifications

Maximum Ratings at Ta=25°C, See specified Test Circuit.

Parameter	Symbol	Conditions	Ratings	Unit
Maximum supply voltage	V _{CC} max	Pins 7, 13	16	V
Maximum output voltage	V _{O5}	Pin 5	17	V
	V _{O8, 11}	Pins 8, 11	24	V
Maximum input voltage	V _{IN} max	Pin 2	5.6	V
Maximum supply current	I _{CC} max	Total of current at pins 5, 7, 8, 11, 13	35	mA
Maximum flow-out current	I ₃	Pin 3	6	mA
Allowable power dissipation	Pd max	Ta≤45°C	520	mW
Operating temperature	T _{opr}		-20 to +70	°C
Storage temperature	T _{stg}		-40 to +125	°C

Recommended Operating Condition at Ta=25°C

Parameter	Symbol	Conditions	Ratings	Unit
Recommended supply voltage	V _{CC}		7.5 to 14.0	V

Operating Characteristics at Ta=25°C, V_{CC}=8V, f_r=1MHz, f_m=400Hz, See specified Test Circuit.

Parameter	Symbol	Conditions	Ratings			Unit
			min	typ	max	
Current drain	I _{CC1}	Quiescent	12.5	18.0	24.5	mA
	I _{CC2}	120dBμ input	14.0	20.0	26.5	mA
Detection output	V _{O1}	24dBμ input, 30% mod.	-31.0	-26.5	-12.0	dBm
	V _{O2}	74dBμ input, 30% mod.	-18.0	-15.5	-12.0	dBm
Signal to noise ratio	S/N 1	24dBμ input, 30% mod.	16	20		dB
	S/N 2	74dBμ input, 30% mod.	46	50		dB
Total harmonic distortion	THD1	74dBμ input, 30% mod.		0.35	1.0	%
	THD2	74dBμ input, 80% mod.		0.35	1.5	%
	THD3	120dBμ input, 30% mod.		0.35	2.0	%
RF AGC voltage (V ₁₆)	V _{RFAGC1}	Quiescent	5.2	5.6	5.9	V
[Reference characteristics]						
Signal to noise ratio	S/N 3	35dBμ input, 30% mod.		31		dB
Total harmonic distortion	THD4	128dBμ input, 80% mod.		0.58		%
Detection output variation	ΔV _O	V _O (128dBμ)/V _O (74dBμ)		0.4		dB
Bandwidth (6dB)	BW ₆	6dB width, 15dBμ input 30% mod.		7		kHz
	BW ₆₀	60dB width, 15dBμ input 30% mod.		30		kHz
Selectivity (1 signal)	ACA	±10kHz detuning, 15dBμ input, 30% mod.		40		dB
Ripple rejection ratio		100dBμ input, IF VCC (pin 13) ripple level 50Hz to 15dBm		40.5		dB
Local oscillation voltage	V _{osc}			350		mVrms
Local osc drift	ΔV _{osc}	V _{oscL} (515kHz) to V _{oscH} (1660kHz)		20		mVrms
Whistle	2f _i Tweet	74dBμ input, 400Hz beat max.		-33		dB
RF AGC voltage (V ₁₆)	V _{RFAGC2}	120dBμ input		1		V
RF output voltage	V _{ORF}	100dBμ input, ±10kHz		300		mVrms
IF interference		f _r =600kHz, 15dBμ input		91.5		dB
Image frequency interference		f _r =1400kHz, 15dBμ input		70.5		dB

LA1130

Sample Application Circuit (excluding the area bounded by the dotted line) / also used as characteristics test circuit.

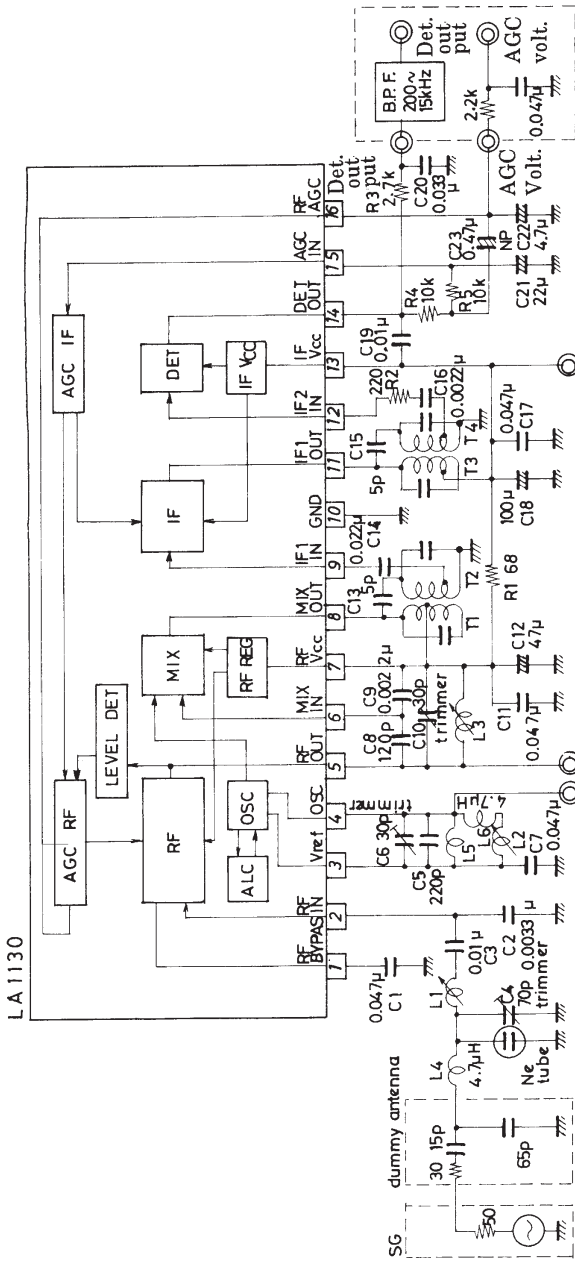

Unit (resistance : Ω , capacitance : F)

※ Adjust trimmer when testing $V_{CC}=8V$

※ RF output

※ OSC output

SG
1MHz
30%400Hz mod.
Input level :
Open circuit voltage
indication
Reading on SG

Coil Specification

	SUMIDA	TOKO	mitsumi
L1			
L2			CMU ZT-01
L3			
L5	51N-190-154	7BR 5721Z	
T1	58H-190-036	7MC 5723Y	
T2	49H-190-036	7MC5722BY	
T3	58H-190-037	7MC 5725Y	
T4	58H-190-035	7MC 5724Y	
T5		CFMA-003	
T6		7MC-5919N	

☆ Application where ceramic filter is used between IF stages

LA1130

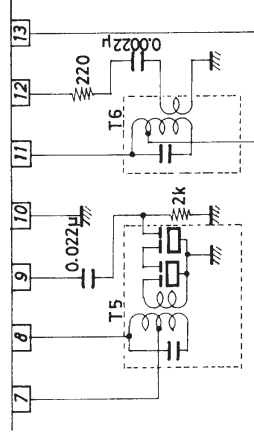

LA1130

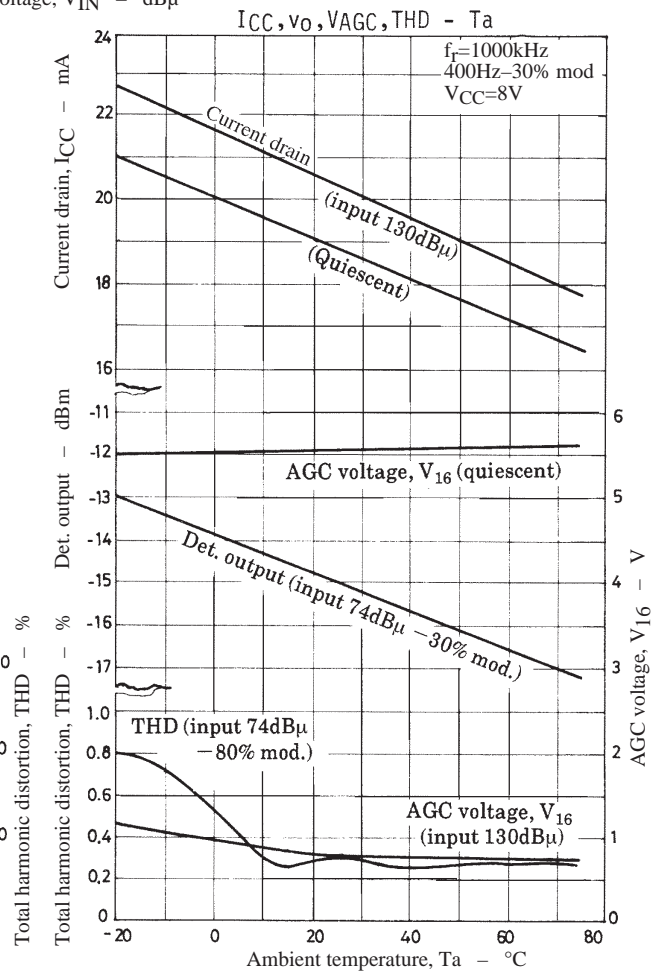
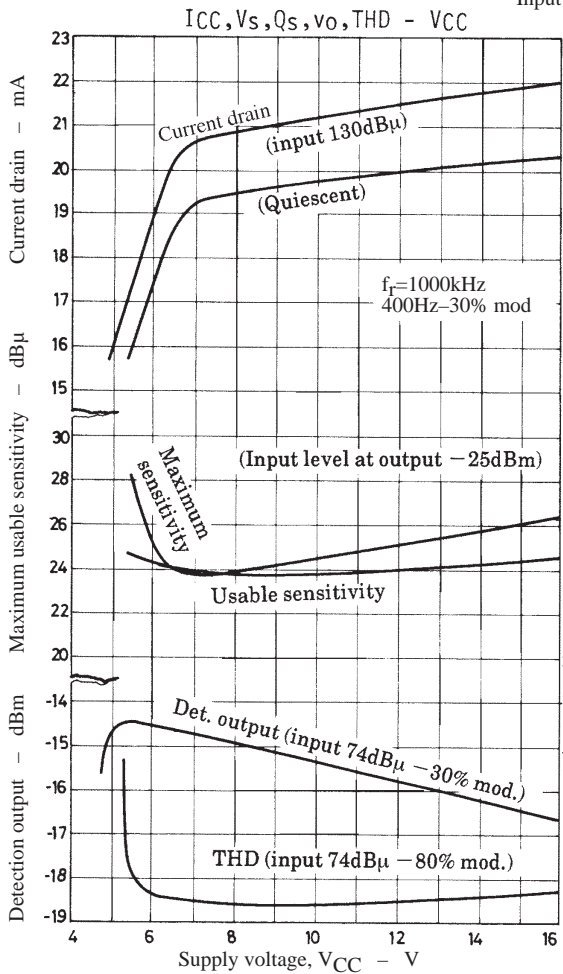
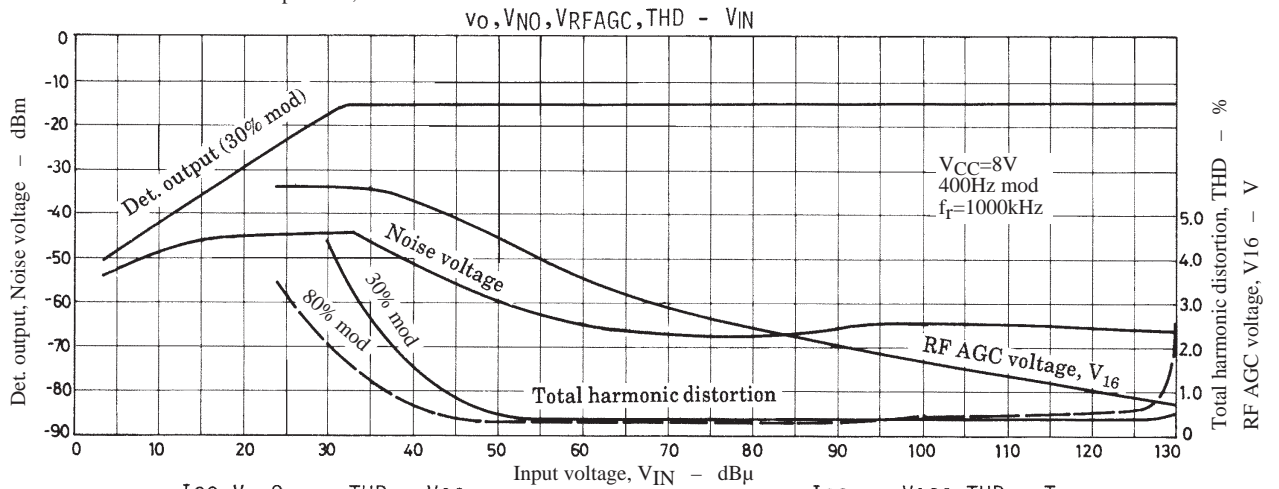
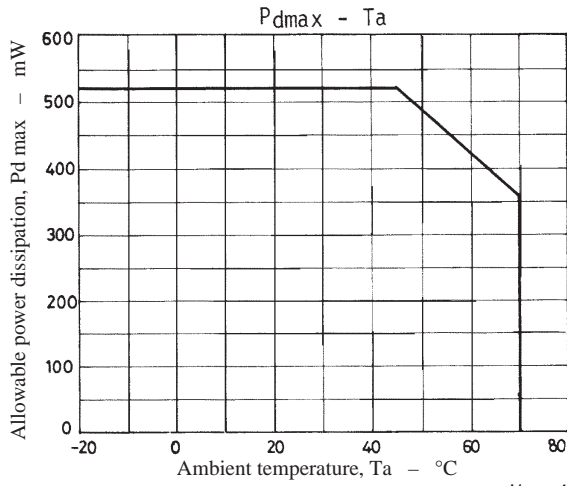

LA1130

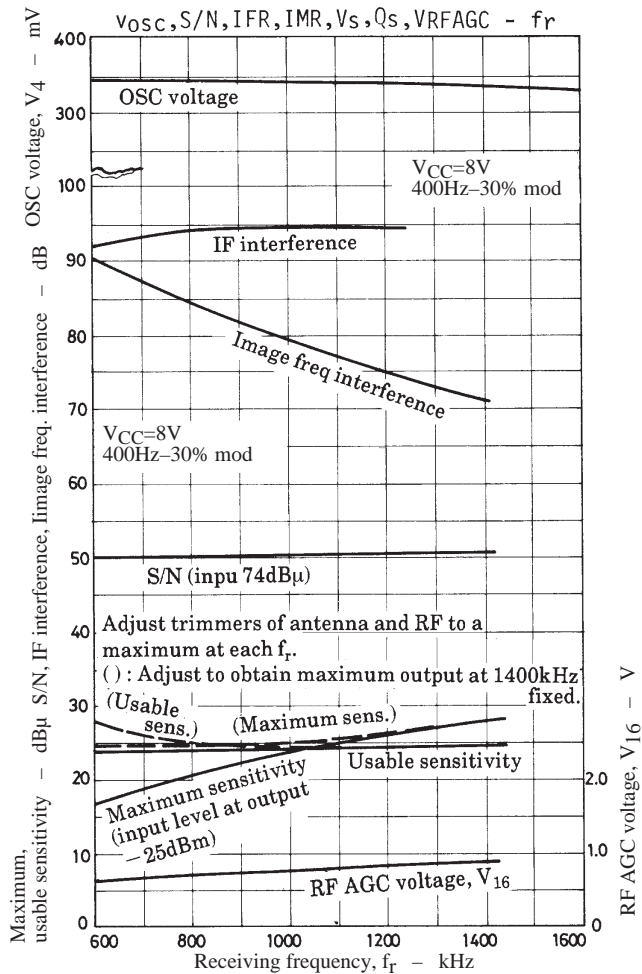

■ No products described or contained herein are intended for use in surgical implants, life-support systems, aerospace equipment, nuclear power control systems, vehicles, disaster/crime-prevention equipment and the like, the failure of which may directly or indirectly cause injury, death or property loss.

■ Anyone purchasing any products described or contained herein for an above-mentioned use shall:

- ① Accept full responsibility and indemnify and defend SANYO ELECTRIC CO., LTD., its affiliates, subsidiaries and distributors and all their officers and employees, jointly and severally, against any and all claims and litigation and all damages, cost and expenses associated with such use:
- ② Not impose any responsibility for any fault or negligence which may be cited in any such claim or litigation on SANYO ELECTRIC CO., LTD., its affiliates, subsidiaries and distributors or any of their officers and employees jointly or severally.

■ Information (including circuit diagrams and circuit parameters) herein is for example only; it is not guaranteed for volume production. SANYO believes information herein is accurate and reliable, but no guarantees are made or implied regarding its use or any infringements of intellectual property rights or other rights of third parties.

This catalog provides information as of September, 1997. Specifications and information herein are subject to change without notice.