

SANYO**LA1827M****Single-Chip Tuner IC for Portable Radio
/Cassette Recorders****Overview**

The LA1827M is a single-chip tuner IC for FM and AM with built-in MPX-VCO which requires no adjustment and no external parts.

Functions

- AM: RF amplifier, mixer, oscillator, IF amplifier, detector, AGC, tuning display output
- FM-FE: RF amplifier, mixer, oscillator
- FM-IF: IF amplifier, quadrature detector, signal strength meter, tuning display output
- MPX: PLL stereo decoder, stereo display output, forced mono, internal VCO

Features

- Single-chip tuner with AM, FM-FE/FM-IF, MPX circuitry
- Built-in adjustment-free MPX-VCO (no ceramic oscillator required)
- FM-DET, adjustment-free (using ceramic discriminator)
- Reduced FM-FE oscillation level
- FM stereo indication and AM/FM tuning indication pins provided.

Specifications**Maximum Ratings at Ta = 25°C**

Parameter	Symbol	Conditions	Ratings	Unit
Maximum supply voltage	V_{CCmax}		7.0	V
Indicator drive current	I_{LED}		20	mA
Allowable power dissipation	$P_d max$	$T_a \leq 70^\circ C$	250	mW
Operating temperature	T_{opr}		-20 to +70	°C
Storage temperature	T_{stg}		-40 to +125	°C

■ Any and all SANYO products described or contained herein do not have specifications that can handle applications that require extremely high levels of reliability, such as life-support systems, aircraft's control systems, or other applications whose failure can be reasonably expected to result in serious physical and/or material damage. Consult with your SANYO representative nearest you before using any SANYO products described or contained herein in such applications.

■ SANYO assumes no responsibility for equipment failures that result from using products at values that exceed, even momentarily, rated values (such as maximum ratings, operating condition ranges, or other parameters) listed in products specifications of any and all SANYO products described or contained herein.

Package Dimensions

unit:mm

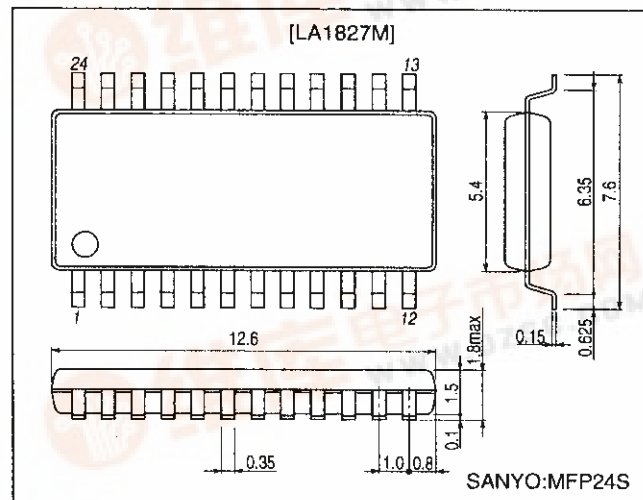
3112-MFP24S

LA1827M

Operating Conditions at Ta = 25°C

Parameter	Symbol	Conditions	Ratings	Unit
Recommended supply voltage	V _{CC}		3.0	V
Operating supply voltage range	V _{CCOP}		1.8 to 6.0	V

Operating Characteristics at Ta = 25°C, V_{CC} = 3.0V, in specified test circuit, using Yamaichi Electronics socket IC51-0242-543

Parameter	Symbol	Conditions	Ratings			Unit
			min	typ	max	
[FM-FE characteristics]: fc = 98 MHz, fm = 1 kHz, 30% mod.						
Local oscillator voltage	V _{osc}	No input, f _{osc} =108.7 MHz, pin 20 output *Measured with FET buffer (-10 dB gain)	35	70	140	mVrms
3 dB sensitivity	3dB LS	60 dBμ, 30% mod. output, -3 dB input		13		dBμ
Effective sensitivity	Qs	Input for S/N = 30 dB		15		dBμ
[FM-IF monaural characteristics]: fc = 10.7 MHz, fm = 1 kHz, 100% mod.						
Quiescent current	I _{CCO} (FM)	No input	8	16	23	mA
Demodulator output	V _O	100 dBμ, pin 16 output	120	160	215	mVrms
Signal-to-noise ratio	S/N	100 dBμ, pin 16 output	63	71		dB
Total harmonic distortion (mono)	THD	100 dBμ, pin 16 output		0.5	1.5	%
3 dB sensitivity	3 dB LS	100 dBμ, 100% mod.output, -3 dB input		35	42	dBμ
TU-LED sensitivity	SD-ON	No modulation		45		dBμ
[FM-IF stereo characteristics]: fc = 10.7 MHz, fm = 1 kHz, L+R = 90%, pilot = 10%						
Separation	SEP	100 dBμ, L-mod, pin 16/pin 17 output	25	40		dB
ST-LED sensitivity	ST-ON	100 dBμ, pilot modulation for pin 8 voltage < 0.5V	1.5	3.5	6.3	%
Total harmonic distortion (main)	THD	100 dBμ, main modulation, pin 16 output		0.5	1.5	%
[AM characteristics]: fc = 1000 kHz, fm = 1 kHz, 30% mod.						
Quiescent current	I _{CCO} (AM)	No input	4	7	12	mA
Detector output	V _{O1}	23 dBμ, pin 16 output	12	25	40	mVrms
	V _{O2}	80 dBμ, pin 16 output	52	78	117	mVrms
Signal-to-noise ratio	S/N1	23 dBμ, pin 16 output	15	20		dB
	S/N2	80 dBμ, pin 16 output	47	53		dB
Total harmonic distortion	THD	80 dBμ, pin 16 output		0.5	1.5	%
TU-LED sensitivity	SD-ON	No modulation		30		dBμ

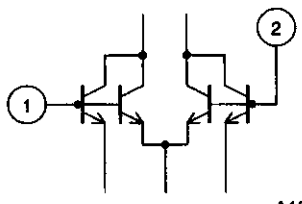
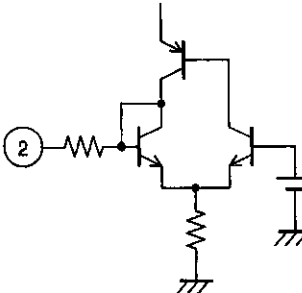

Pin Description and Quiescent Voltage at V_{CC} = 3.0V

Pin number	Function	Quiescent voltage (V)		Equivalent circuit	Remarks
		AM	FM		
1	AM RF input	1.2	1.2	 A10836	AM antenna coil connected between pins 1 and 2 (reg)
2	Reg	1.2	1.2	 A10837	

Continued on next page

LA1827M

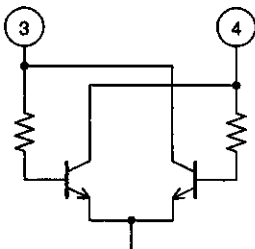
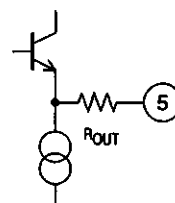
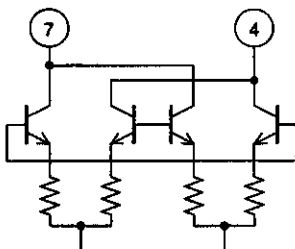
Continued from preceding page

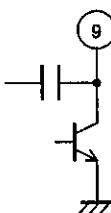
Pin number	Function	Quiescent voltage (V)		Equivalent circuit	Remarks
		AM	FM		
3	AM-OSC	3.0	3.0	 <p style="text-align: right;">A10838</p>	Oscillator coil connected between pins 3 and 4 (V_{CC1})
4	V_{CC1}	3.0	3.0		AM/FM-IN/MPX block V_{CC}
5	FM mixer output	1.4	1.2	 <p style="text-align: right;">A10839</p>	$R_{OUT} = 270\Omega$
6	GND1	0	0		AM/FM-IN/MPX section ground
7	AM mixer output	3.0	3.0	 <p style="text-align: right;">A10840</p>	Mixer coil connected between pins 7 and 4 (V_{CC1})
8	Tu-LED output	3.0	3.0	 <p style="text-align: right;">A10841</p>	Active low Open-collector output can directly drive LED ($I_C \text{ max} = 20 \text{ mA}$)
9	ST-LED output and AM-IF output	3.0	3.0	 <p style="text-align: right;">A10842</p>	Active low Open-collector output can directly drive LED ($I_C \text{ max} = 20 \text{ mA}$) In AM operation, AM-IF signal (450 kHz) is output here.

Continued on next page

LA1827M

Continued from preceding page

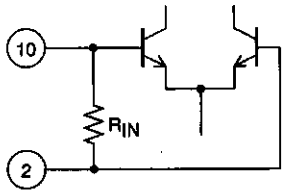
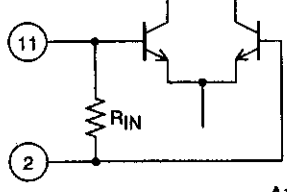
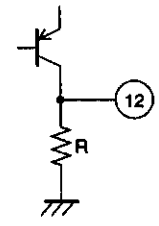
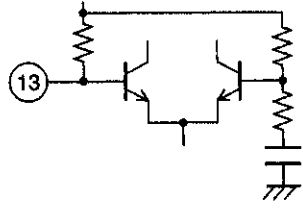
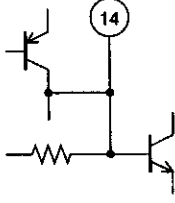
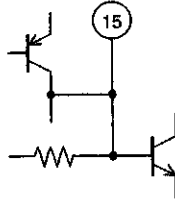
Pin number	Function	Quiescent voltage (V)		Equivalent circuit	Remarks
		AM	FM		
10	FM-IF input	1.2	1.2	 <p style="text-align: right;">A10843</p>	$R_{IN} = 330 \Omega$
11	AM-IF input	1.2	1.2	 <p style="text-align: right;">A10844</p>	$R_{IN} = 2 \text{ k}\Omega$
12	AM-AGC output and FM signal meter output	0.5	0.1	 <p style="text-align: right;">A10845</p>	Internal load resistance $R = 16.6 \text{ k}\Omega$
13	FM detector	2.4	2.2	 <p style="text-align: right;">A10846</p>	Recommended ceramic discriminator CDF107F-AE-019 (Toko) CDA10.7MG83 (Murata)
14	Pilot tone detector filter and forced mono switching	1.7	2.3	 <p style="text-align: right;">A10847</p>	Mono mode is forced on by connecting pin 14 to ground.
15	Phase comparator filter and AM/FM switching	0	2.3	 <p style="text-align: right;">A10848</p>	FM reception mode is enabled when pin 15 is open. AM reception mode is enabled when pin 15 is connected to ground.

Continued on next page

LA1827M

Continued from preceding page

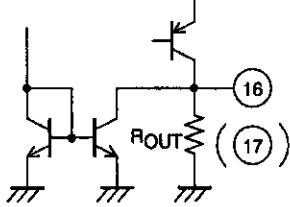
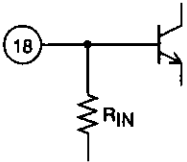
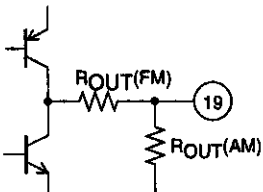
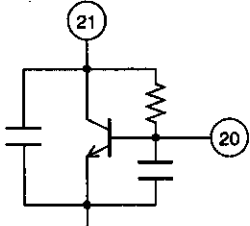
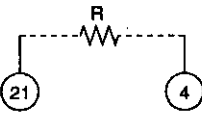
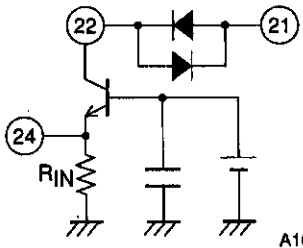
Pin number	Function	Quiescent voltage (V)		Equivalent circuit	Remarks
		AM	FM		
16 17	L output R output	1.2	1.2	 <p>A10849</p>	$R_{OUT} = 7.5 \text{ k}\Omega$
18	MPX input	1.2	1.2	 <p>A10850</p>	$R_{IN} = 50 \text{ k}\Omega$
19	FM detector output and AM detector output	0.4	1.2	 <p>A10851</p>	Output impedance AM: $R_{OUT} = 50 \text{ k}\Omega$ FM: $R_{OUT} = 500 \Omega$ Capacitance between pin 19 and ground should be optimized for the best separation characteristics.
20	FM-OSC	3.0	2.9	 <p>A10852</p>	Colpitts oscillator circuit FM oscillator coil is connected to pin 20.
21	V_{CC2}	3.0	2.9	 <p>A10853</p>	FM-FE block V_{CC} Power is supplied from pin 4 (V_{CC1}) via external resistor (10Ω).
22 24	FM-RF output FM-RF input	3.0 0	2.9 0.8	 <p>A10854</p>	FM RF coil is connected between pins 22 and 21 (V_{CC2}). $R_{IN} = 1.8 \text{ k}\Omega$
23	GND2	0	0		FM-FE block ground

LA1827M

Coil specifications (bottom view)

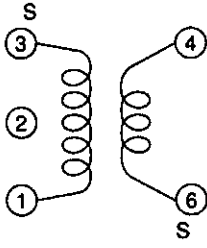
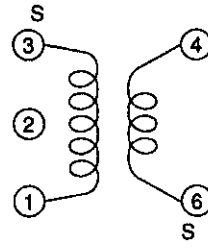
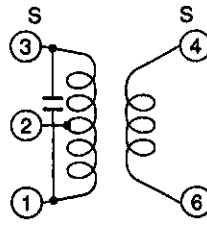
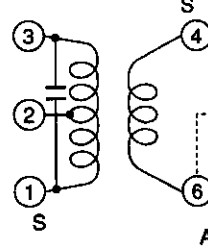
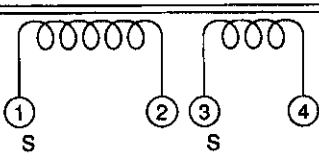
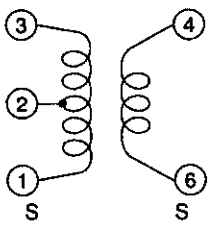
<p>• FM-BPF: SA-309 (Sumida) 88 to 108 MHz</p>	
<p>• FM-RF: SA-149 (Sumida) 3.6 mm dia., air core, 0.6 mm wire, 4 1/2 T</p>	
<p>• FM-OSC: SA-151 (Sumida) 3.6 mm dia., air core, 0.6 mm wire, 3 1/2 T</p>	
<p>• FM-IF filter, discriminator: SK107M1-AE-10, CDF107F-AE-019, $R_s=510\Omega$ (Toko) SEF10, 7MA5, CDA10.7MG83, $R_s=470\Omega$ (Murata)</p>	
<p>• AM-OSC: SA-181 (Sumida)</p>  <p>③ - ④ 37T ③ - ① 74T 0.06 UEW $f_0 = 796$ kHz $Q_0 \geq 80$ $L = 140\mu\text{H}$</p> <p>A10830</p>	<p>• L7BRS-3132AQ (Toko)</p>  <p>③ - ① 64T ③ - ④ 32T 0.06 2UEW $f_0 = 796$ kHz $Q_0 \geq 65$ $L = 140\mu\text{H}$</p> <p>A10831</p>
<p>• AM-IFT: SA-1138 (Sumida)</p>  <p>③ - ② 122T ④ - ⑥ 9T ② - ① 62T 0.06UEW $f_0 = 450$ kHz $Q_0 \geq 65$ With 180 pF internal capacitor</p> <p>A10832</p>	<p>• PCFAZ-082 (Toko)</p>  <p>① - ② 47T ② - ③ 100T ④ - ⑥ 12T $f_0 = 450$ kHz With 180 pF internal capacitor With AM-IF filter</p> <p>ACFA-450L08 A10833</p>
<p>• AM-IF filter: SFU450B (Murata)</p>	
<p>• Poly-varicon: FT-2217 (Toko) PVC-22KTL (Mitsumi)</p>	<p>• MW Bar- antenna: TYA-1005 (Mitsumi)</p>  <p>① - ② 68T ③ - ④ 9T $f_0 = 796$ kHz $Q_0 \geq 230$ $L = 260\mu\text{H}$</p> <p>A10834</p>
<p>For DUT PCB</p>	
<p>• FM-Discriminator: CDA10.7 MG1-B (Murata)</p>	<p>• AM-OSC: SA-1135 (Sumida)</p>  <p>③ - ④ 11T ① - ② 99T ② - ③ 3T 0.06UEW $f_0 = 796$ kHz $Q_0 \geq 80$ $L = 270\mu\text{H}$</p> <p>A10835</p>

Block Diagram

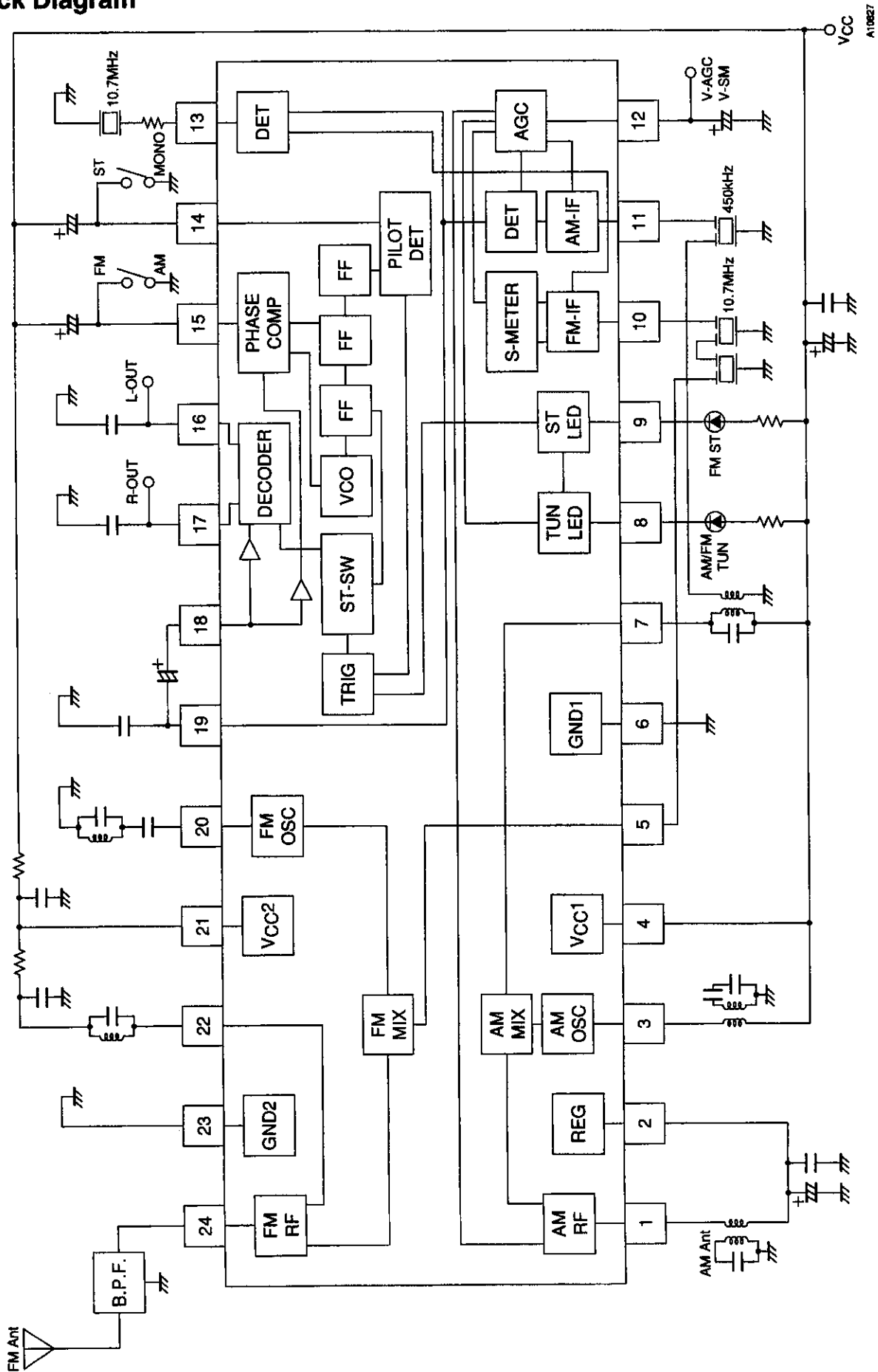

LA1827M

Test Circuit

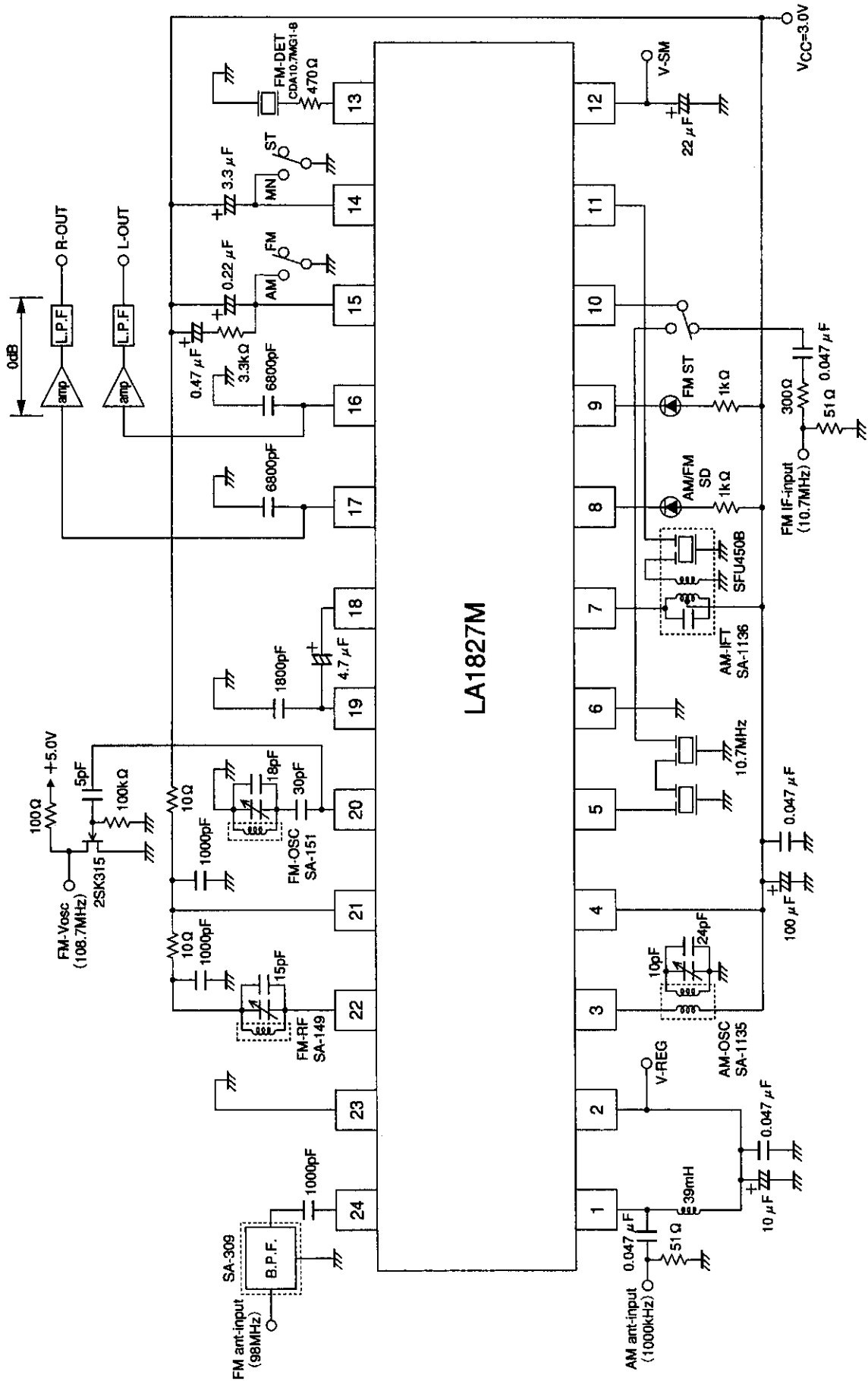

A10828

LA1827M

Sample Application Circuit

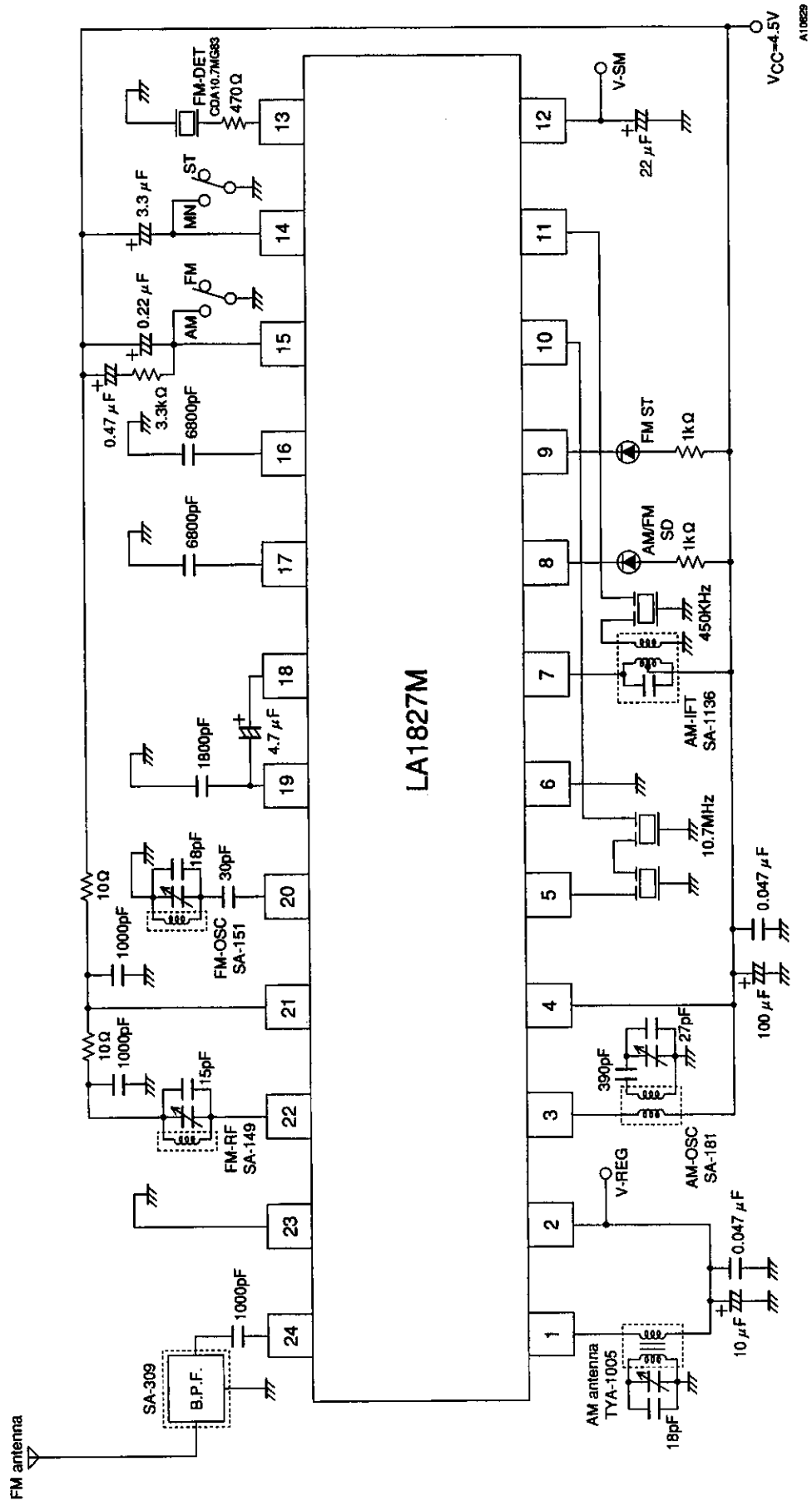

LA1827M

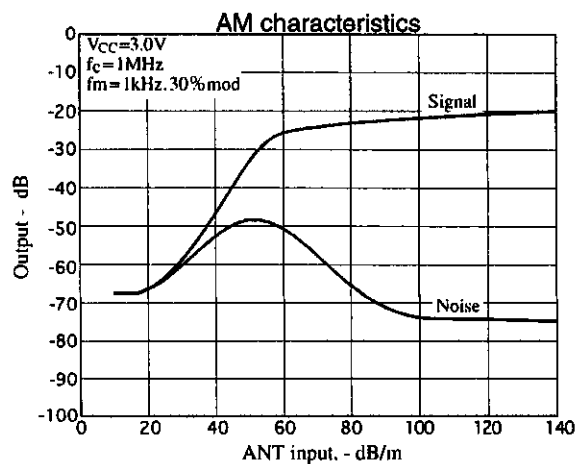
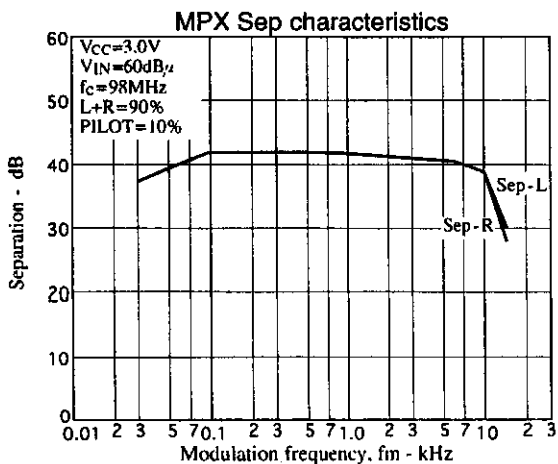
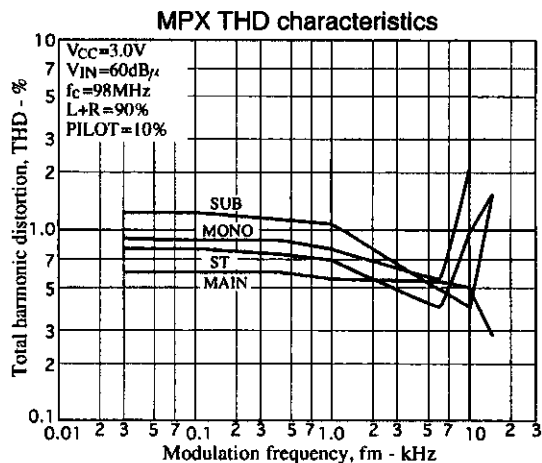
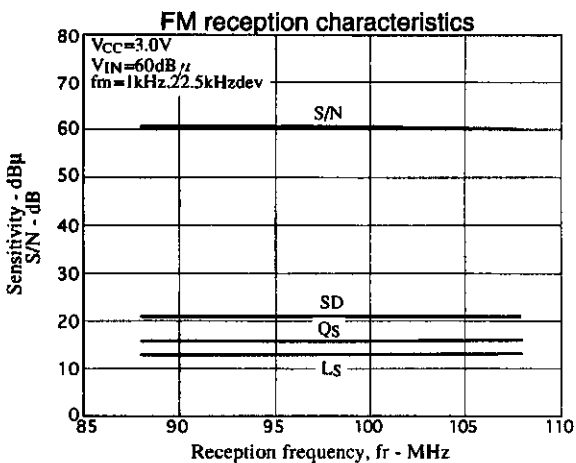
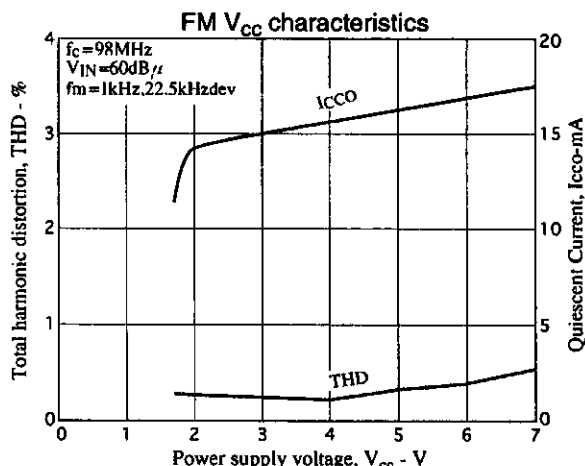
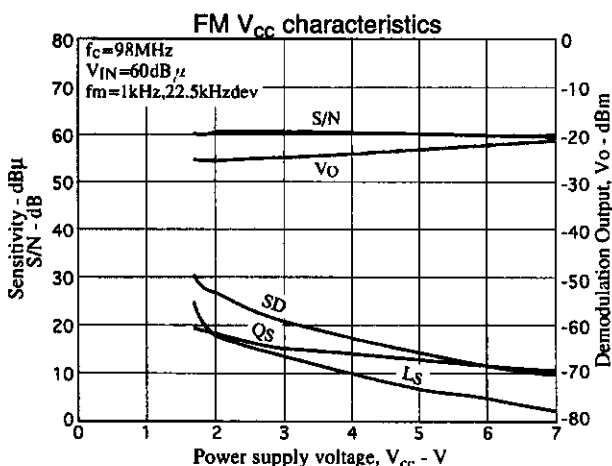
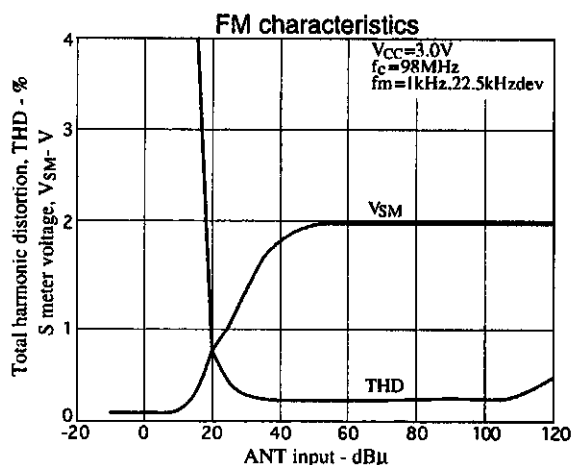
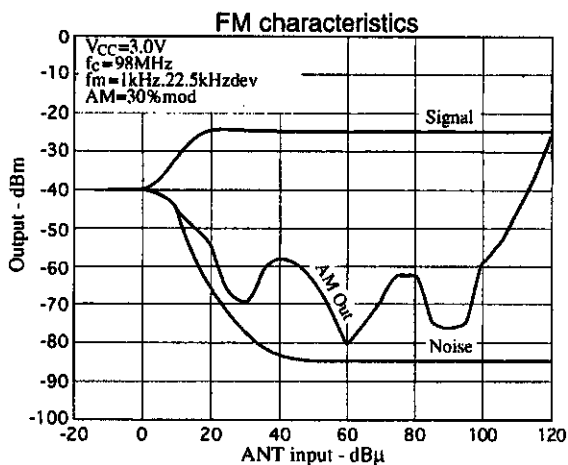

LA1827M

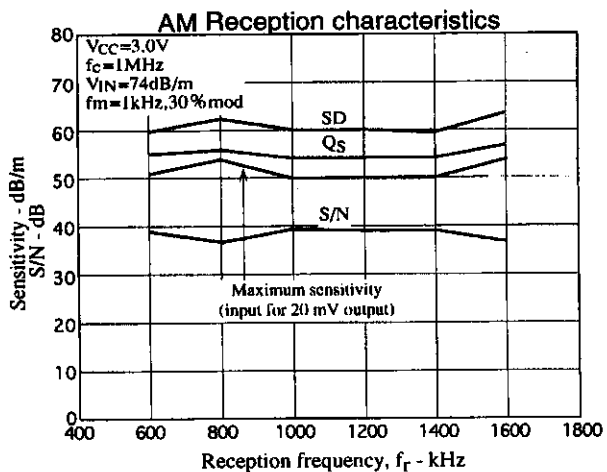
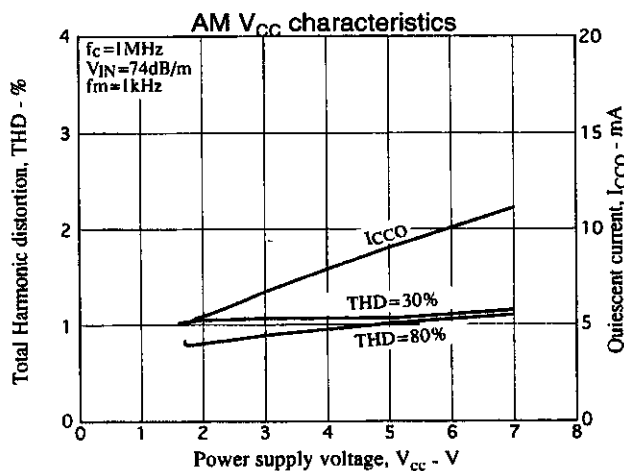
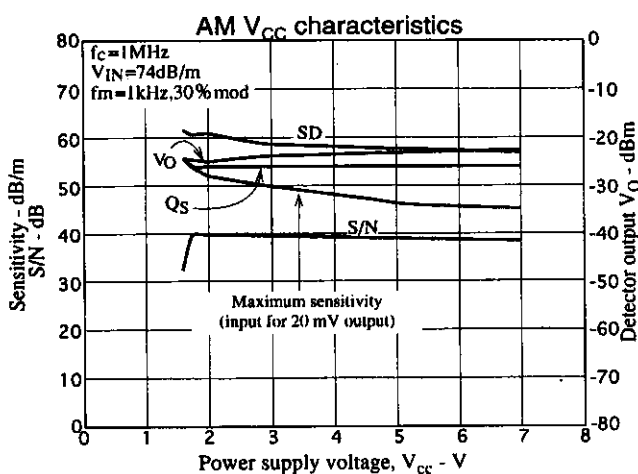
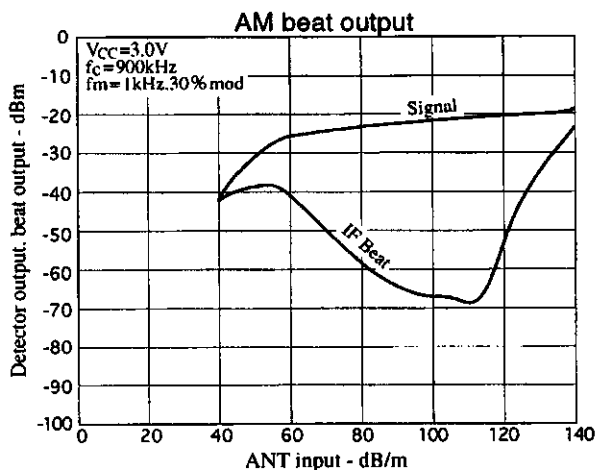
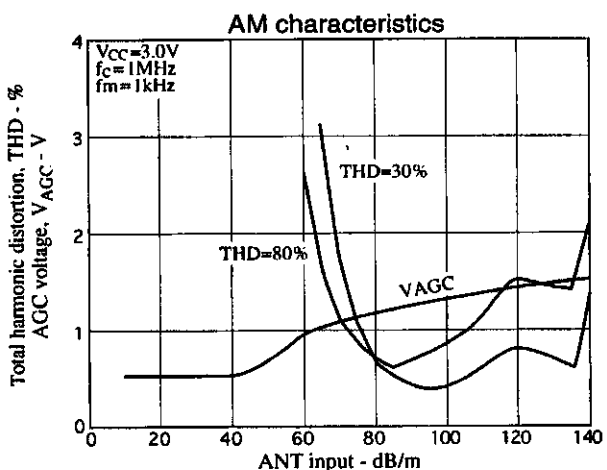

- Specifications of any and all SANYO products described or contained herein stipulate the performance, characteristics, and functions of the described products in the independent state, and are not guarantees of the performance, characteristics, and functions of the described products as mounted in the customer's products or equipment. To verify symptoms and states that cannot be evaluated in an independent device, the customer should always evaluate and test devices mounted in the customer's products or equipment.
- SANYO Electric Co., Ltd. strives to supply high-quality high-reliability products. However, any and all semiconductor products fail with some probability. It is possible that these probabilistic failures could give rise to accidents or events that could endanger human lives, that could give rise to smoke or fire, or that could cause damage to other property. When designing equipment, adopt safety measures so that these kinds of accidents or events cannot occur. Such measures include but are not limited to protective circuits and error prevention circuits for safe design, redundant design, and structural design.
- In the event that any and all SANYO products described or contained herein fall under strategic products (including services) controlled under the Foreign Exchange and Foreign Trade Control Law of Japan, such products must not be exported without obtaining export license from the Ministry of International Trade and Industry in accordance with the above law.
- No part of this publication may be reproduced or transmitted in any form or by any means, electronic or mechanical, including photocopying and recording, or any information storage or retrieval system, or otherwise, without the prior written permission of SANYO Electric Co., Ltd.
- Any and all information described or contained herein are subject to change without notice due to product/technology improvement, etc. When designing equipment, refer to the "Delivery Specification" for the SANYO product that you intend to use.
- Information (including circuit diagrams and circuit parameters) herein is for example only ; it is not guaranteed for volume production. SANYO believes information herein is accurate and reliable, but no guarantees are made or implied regarding its use or any infringements of intellectual property rights or other rights of third parties.