



No.1125D

Monolithic Linear IC

# LA2113

FM NOISE CANCELER

The LA2113 is a DIP-16 version of the LA2110. It has the capability to effectively remove external noise (pulse noise) caused by engine, etc. and is used in conjunction with a PLL FM multiplex stereo demodulator (LA3373 and the like) with pilot signal canceler.

**Features**

- . Pilot signal compensation function.
- . By using in conjunction with PLL FM multiplex stereo demodulator with pilot signal canceler, adverse effect caused by pilot signal can be compensated.
- . Low distortion : THD=0.02%,300mV
- . Variable input type noise AGC system : This system widens the noise detector's dynamic range, so that pulse noise can be satisfactorily detected even in a weak electric field, and pulse noise is removed without adversely affecting distortion.

**Maximum Ratings at Ta=25°C**

			unit
Maximum Supply Voltage	VCCmax	16	V
Allowable Power Dissipation	Pgmax	450	mW
Operating Temperature	Topr	-20 to +75	°C
Storage Temperature	Tstg	-40 to +125	°C

**Recommended Operating Conditions at Ta=25°C**

			unit
Recommended Supply Voltage	VCC	12	V
Operating Voltage Range	VCCOP	8 to 15	V

**Operating Characteristics at Ta=25°C, VCC=12V, See specified Test Circuit.**

			(Input pin)	(Output pin)	min	typ	max	unit
Quiescent Current	Icco					16	25	mA
Voltage Gain	VG	V7=300mV, f=1kHz	OUTPUT		-0.2	0.8	1.8	dB
Input Signal Dynamic Range	VD	V7, f=1kHz	OUTPUT, THD=1%		1.3			V
Input Impedance	Zin	V7=300mV, f=1kHz			36k	51k	67k	ohm
Total Harmonic Distortion	THD	V7=300mV, f=1kHz	OUTPUT		0.01	0.03		%
Low-Pass Amp Gain	VG <sub>L</sub>	V5=300mV, f=1kHz	V4		1.0	1.1	1.2	time
High-Pass Amp Gain	VG <sub>H</sub>	V9=100mV, f=200kHz	V10		1.2	1.4	1.65	time
Inverting Amp Distortion	THD <sub>I</sub>	V15=100mV, f=19kHz	OUTPUT				0.1	%
Inverting Amp Dynamic Range	VD <sub>I</sub>	V15, f=19kHz	OUTPUT, THD=1%	300				mV

Continued on next page.

**Package Dimensions (unit: mm)**  
**3006B**

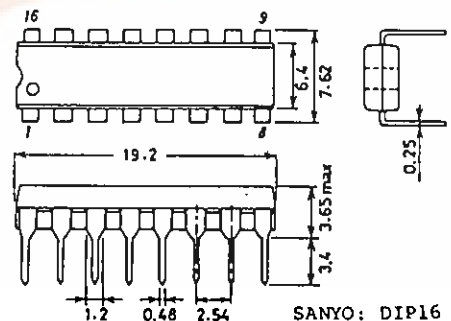

# LA2113

Continued from preceding page.

		(Input pin)	(Output pin)	min	typ	max	unit
Inverting Amp Gain	VGI	V15=100mV, f=19kHz	OUTPUT	1.0	1.3	1.6	time
Output Noise Voltage	VNO	V7, V15 shorted to GND	OUTPUT, 100kHz low-pass filter	30	60	60	$\mu$ V
Gate Time	t <sub>gate</sub>	V7=100mV <sub>p-p</sub> , f=1kHz	OUTPUT	13	21	30	$\mu$ s
Noise Sensitivity	SN	V7, f=1kHz	OUTPUT			30	mV <sub>p-0</sub>

## Test Circuit

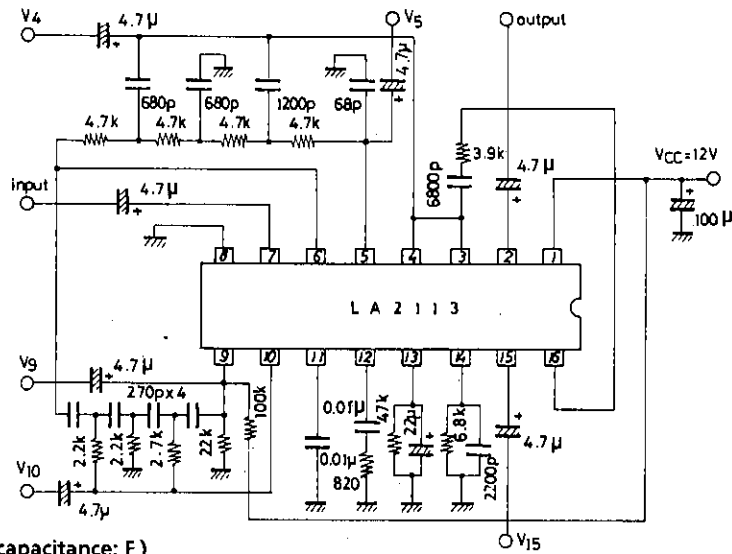

Unit (resistance:  $\Omega$ , capacitance: F)

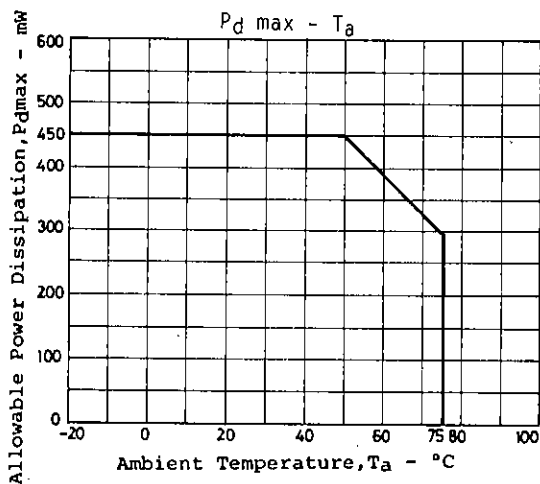

Equivalent Circuit Block Diagram

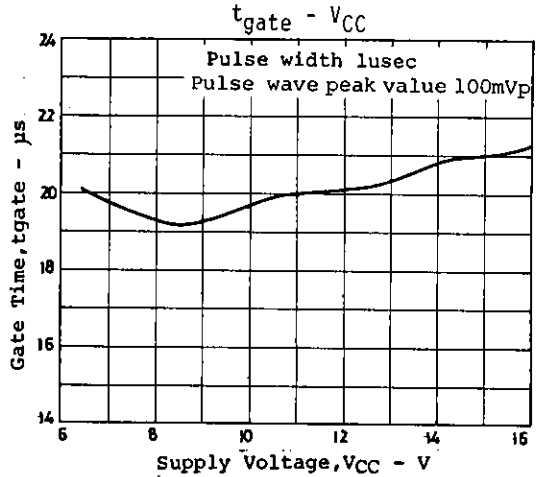
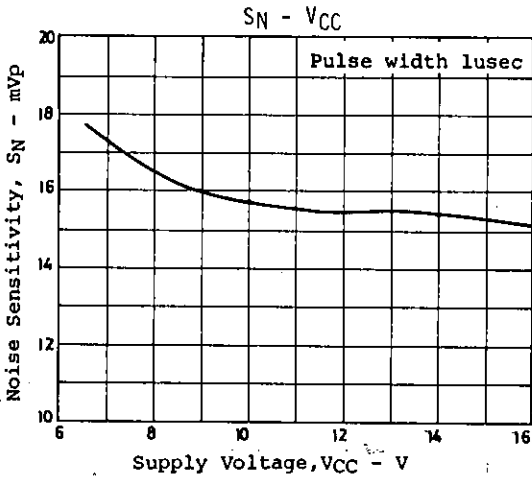
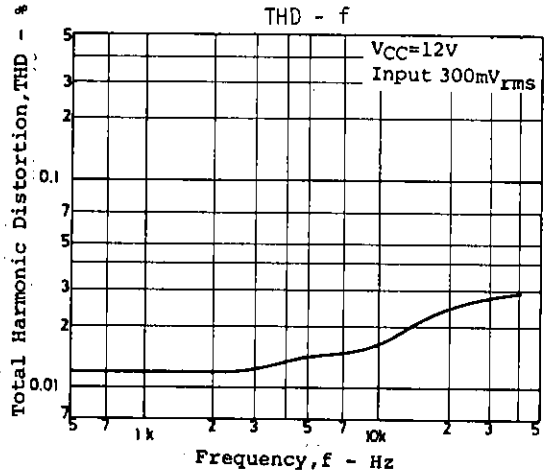
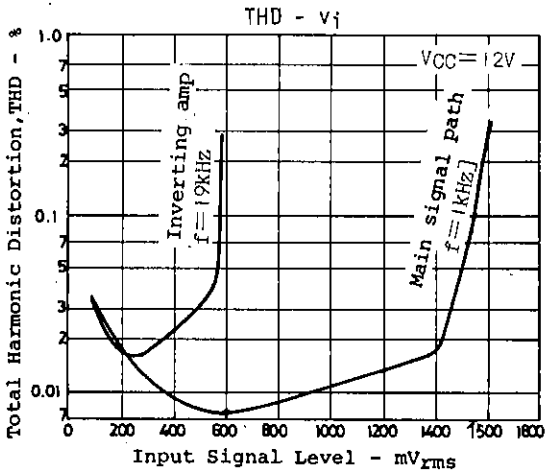
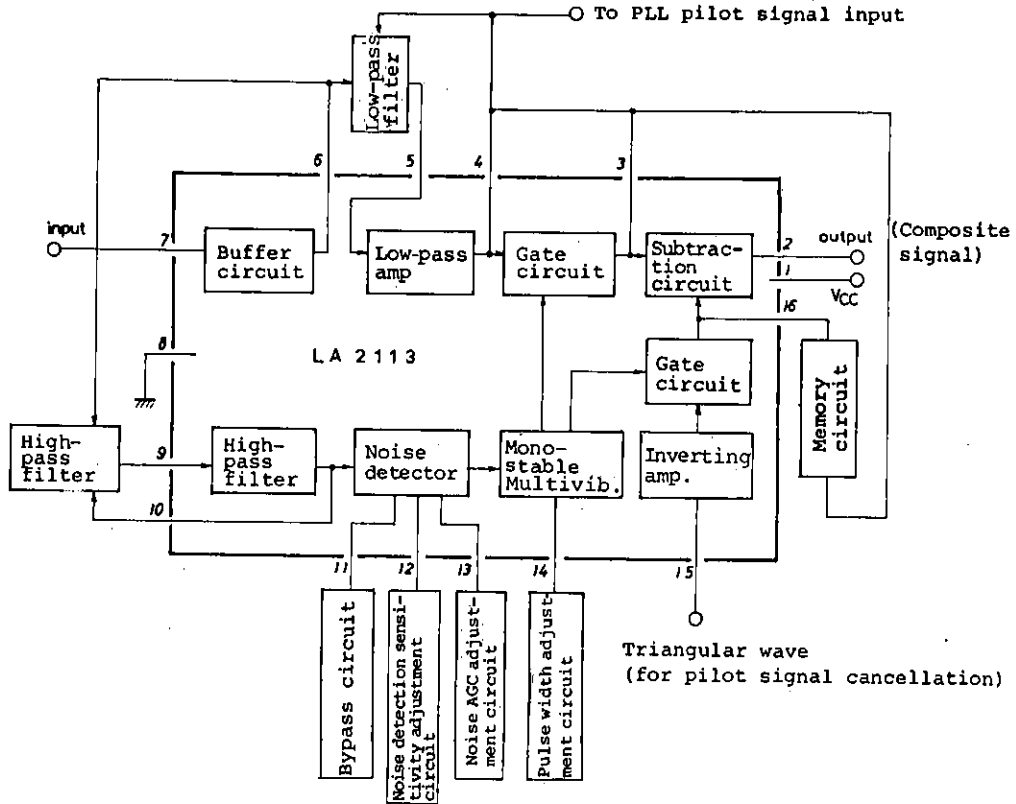

## [Theory of LA2113 Noise Canceller]

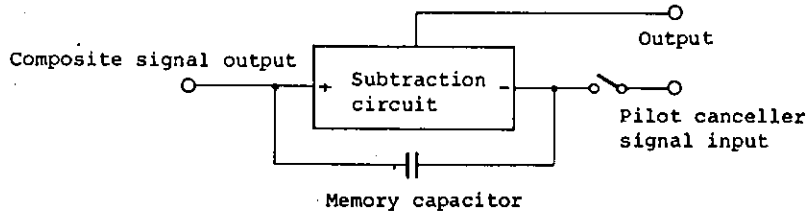

In order to simplify the operation theory, the composite signal component is given only as a low frequency signal and a pilot signal, and the pilot cancel signal has the same phase, same amplitude as the pilot signal in the composite signal.

Since the output voltage is the differential voltage of the plus and minus input of the subtraction circuit, it is equal to the voltage between the memory capacitor terminals. When the gate is closed, the composite signal is applied to the plus input terminal of the subtraction circuit, and the pilot cancel signal is applied to the minus input terminal. Thus the pilot signal is cancelled from the output and only the low frequency signal appears. In the same way, the voltage between the memory capacitor terminals is the differential voltage of the composite signal and the pilot cancel signal, so only the low frequency signal appears.

When pulse noise is generated and the gate opens, the plus input and minus input signal waveforms of the subtraction circuit become equal. This is because the input impedance of the subtraction circuit is extremely high, so the memory capacitor is considered AC-shorted. Thus, when pulse noise is generated in the composite signal is the voltage held by the memory capacitor. This voltage is that between subtraction circuit. As a result, pulse noise does not appear in the output. The voltage in the output has a DC level difference of plus and minus input, and that is the voltage maintained by the memory capacitor. This voltage is that between the memory capacitor terminals just before the gate opens, so it is the low frequency signal voltage just before the gate opens. Because the subtraction circuit input impedance is high, no charge/discharge current flows in the memory capacitor while the gate is open, so the memory capacitor can hold the voltage between its terminals.

The voltage waveforms are illustrated below.

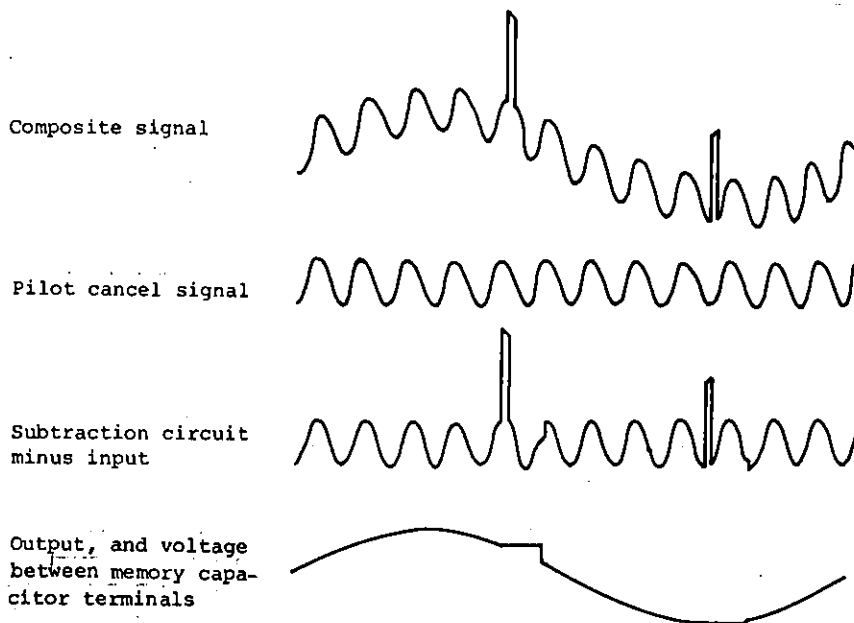

# LA2113

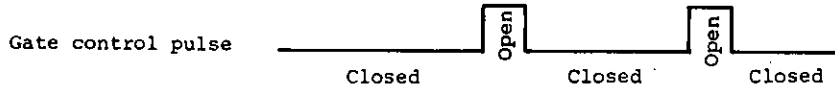

Note : The pilot cancel signal is given as sinusoidal in this explanation, but in the actual specimen application circuit, pilot cancel is performed by a triangular wave.

## Sample Application Circuit: LA2113 & LA3373

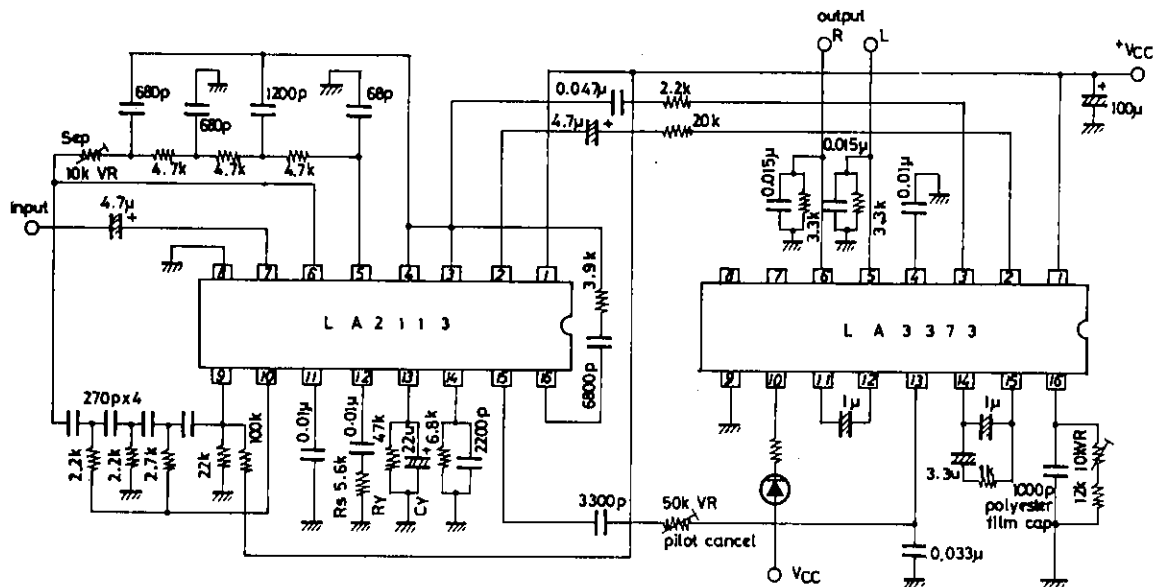

### Note : When using the Sample Application Circuit:

1. Separation adjustment is performed with 10kohms variable resistance in low-pass filter.
2. Change noise detection sensitivity control  $R_s$  to an adequate value for strong or medium electric field.
3. Adjust noise AGC with  $C_y$ ,  $R_y$  for effective noise suppression in a medium or weak electric field.
4. Adjust pilot cancel degree with variable resistance of 50kohms connected to LA2113 pin 15.
5. By changing the  $1\mu\text{F}$  capacitor between LA3373 pin 11 and 12, pilot cancel follow-up response time can be changed. But if the value is decreased, distortion factor, etc., will be adversely affected.

For detailed data on the Sample Application Circuit, refer to the catalog of the LA2110.

- No products described or contained herein are intended for use in surgical implants, life-support systems, aerospace equipment, nuclear power control systems, vehicles, disaster/crime-prevention equipment and the like, the failure of which may directly or indirectly cause injury, death or property loss.
- Anyone purchasing any products described or contained herein for an above-mentioned use shall:
  - ① Accept full responsibility and indemnify and defend SANYO ELECTRIC CO., LTD., its affiliates, subsidiaries and distributors and all their officers and employees, jointly and severally, against any and all claims and litigation and all damages, cost, and expenses associated with such use:
  - ② Not impose any responsibility for any fault or negligence which may be cited in any such claim or litigation on SANYO ELECTRIC CO., LTD., its affiliates, subsidiaries and distributors or any of their officers and employees jointly or severally.
- Information (including circuit diagrams and circuit parameters) herein is for example only; it is not guaranteed for volume production. SANYO believes information herein is accurate and reliable, but no guarantees are made or implied regarding its use or any infringements of intellectual property rights or other rights of third parties.