

Ordering number : EN4416A

Monolithic Linear IC



LA2232, 2232M

RDS Decoder

Overview

The LA2232 and LA2232M are RDS demodulator ICs that provide both a 57 kHz bandpass filter as well as ARI-SK and DK signal recognition functions on chip. Cost-effective RDS decoder systems can be constructed by using an LA2232 or 2232M in conjunction with a synchronization and error detection/correction LSI from the LC7070 series. The LA2232 and 2232M provide improved sensitivity LA2230 and 2230M.

Applications

- RDS signal demodulation
- ARI signal demodulation and SK and DK recognition

Functions

- 57 kHz bandpass filter
- RDS signal demodulation
- Bit rate clock regeneration
- RDS identification output
- ARI signal demodulation
- SK identification output
- DK identification output
- Adjustable ARI detection sensitivity

Features

- High RDS demodulation sensitivity
- Reduced costs and PCB area due to the inclusion of an on-chip 57 kHz bandpass filter
- Supports improved interference rejection characteristics by providing ARI detection sensitivity adjustment
- Quick operation startup due to a built-in rapid charging circuit for use at power application.

Package Dimensions

unit: mm

3067-DIP24S

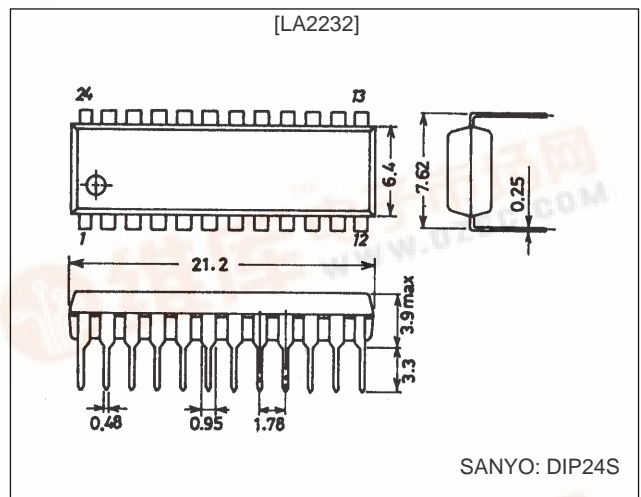

unit: mm

3112-MFP24S

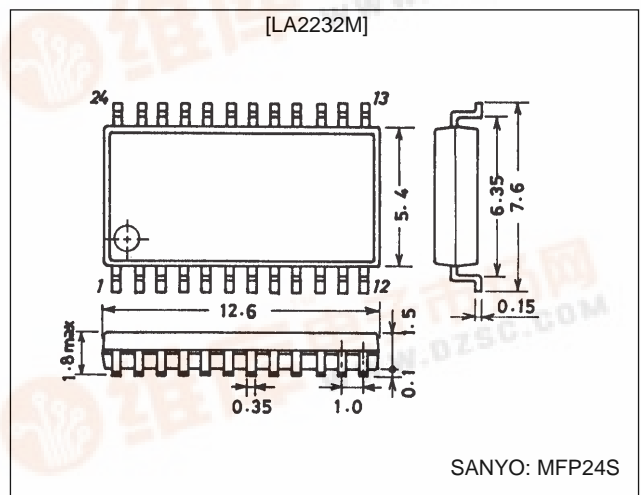

LA2232, 2232M

Specifications

Maximum Ratings at Ta = 25°C

Parameter	Symbol	Conditions	Ratings	Unit
Maximum supply voltage	V _{CC} max	Pins 13, 14, 15, 23	12	V
Allowable power dissipation	Pd max	LA2232: Ta ≤ 80°C	450	mW
		LA2232M: Ta ≤ 37.5°C	450	mW
		LA2232M: Ta = 80°C	280	mW
Entering current	I _{LED}	Pins 13, 14, 15	20	mA
Operating temperature	T _{opr}		-30 to +80	°C
Storage temperature	T _{stg}	LA2232	-40 to +125	°C
		LA2232M	-40 to +150	°C

Operating Conditions at Ta = 25°C

Parameter	Symbol	Conditions	Ratings	Unit
Recommended supply voltage	V _{CC}	Pin 23	5.0	V
Operating voltage range	V _{CC} op	Pin 23	4.7 to 5.5	V

Operating Characteristics at Ta = 25°C, V_{CC} = 5.0 V

Parameter	Symbol	Ratings			Unit
		min	typ	max	
Quiescent current		14	22	28	mA
Band pass filter gain	f = 57 kHz	9	12.5	17	dB
Band pass filter selectivity	f = 60 kHz (57 kHz = 0 dB)	-6	-2.5	0	dB
	f = 54 kHz (57 kHz = 0 dB)	-6	-3.5	0	dB
	f = 38 kHz (57 kHz = 0 dB)		-39	-33	dB
PLL capture range	5 mVrms CW input		-0.5 +0.8		% %
RDS detection sensitivity	The pin 6 input when pin 15 goes low		0.4	1.0	mVrms
SK detection sensitivity	The pin 6 input when pin 14 goes low		1.0	2.0	mVrms
DK detection sensitivity	The pin 6 input when pin 13 goes low		1.1	2.0	mVrms
Input dynamic range	RDS	The maximum input on pin 6 for the (ARI + RDS) signal when pin 15 goes low	30	50	mVrms
		The maximum input on pin 6 for the RDS signal when pin 15 goes low	250		mVrms
	DK	The maximum input on pin 6 for the ARI signal when pin 15 goes low	75	100	mVrms
Bit rate clock jitter		±8	±9	±10	µs
RDS lockup time	The time until pin 15 goes low following RDS becoming a 3 mV input		35		ms
SK lockup time	The time until pin 14 goes low following ARI becoming an 8 mV input		45		ms
SK + RDS lockup time	The time until pin 15 goes low following RDS + ARI becoming an 8.5 mV input		80		ms
Data output	The high level for pin 17	4.7	4.9	5.0	V
	The low level for pin 17	0	0.1	0.3	V
Bit rate clock output	The high level for pin 18	4.7	4.9	5.0	V
	The low level for pin 18	0	0.1	0.3	V
VCO free-running frequency		453	456	459	kHz

LA2232, 2232M

Equivalent Circuit Block Diagram

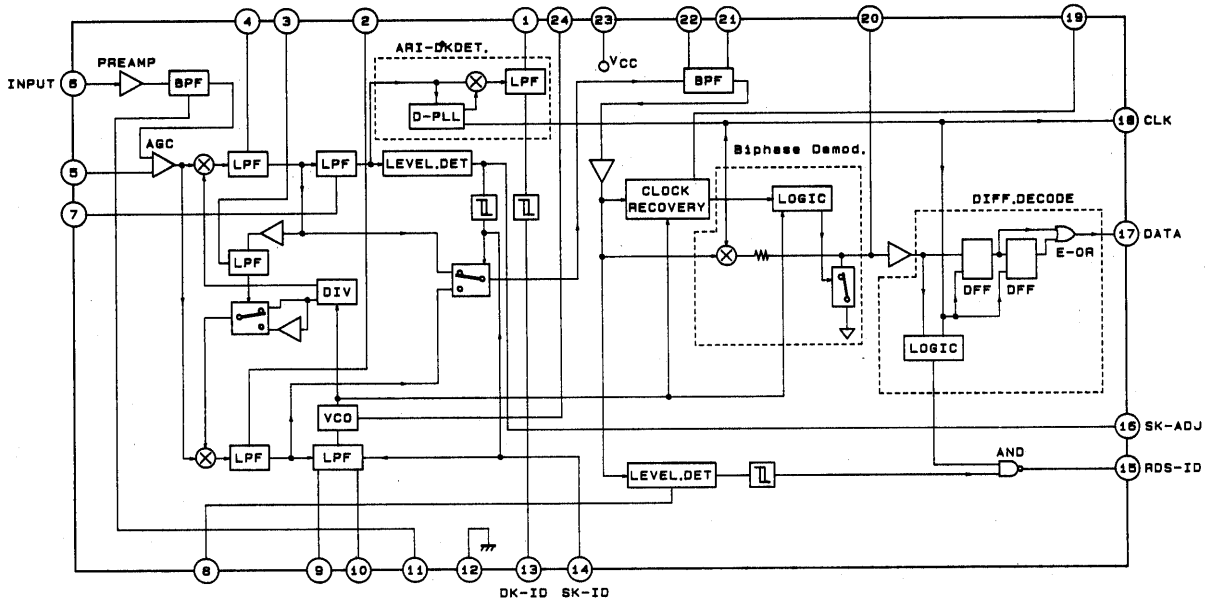

A01104

Test Circuit

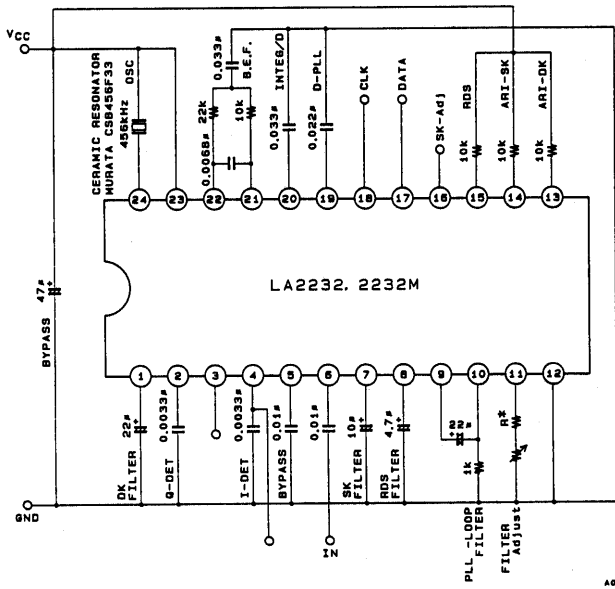

A01108

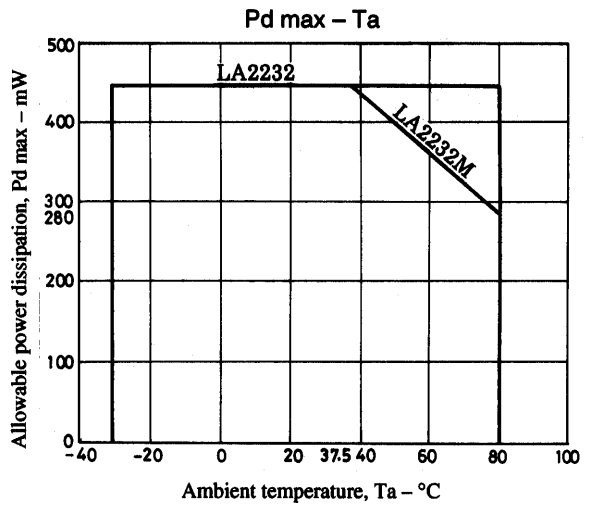

*R = 6.8 kΩ (for the LA2232)
R = 5.6 kΩ (for the LA2232M)

Unit (resistance: Ω, capacitance: F)

LA2232, 2232M

Sample Application Circuit Using the LA2232/M and the LC7073/M

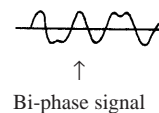
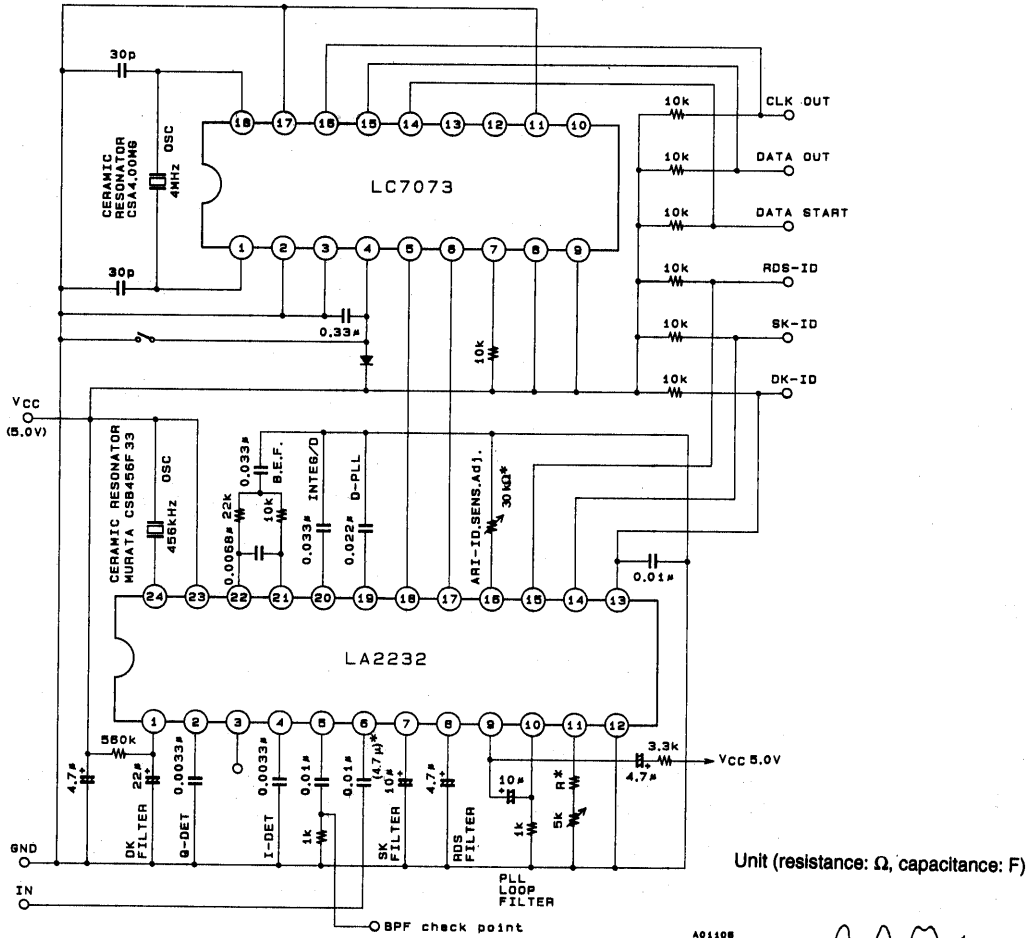

3 to 6 mVrms
Recommended input signal level
(when RDS $\Delta f = \pm 2.0$ kHz)

*R = 6.8 k Ω (for the LA2232)
R = 5.6 k Ω (for the LA2232M)

Adjusting the 57 kHz BPF

- (A) Check the output level of the bi-phase signal from pin 4 or pin 22 (with the pin 6 RDS input at about 1 mVrms and the ALC circuit not operating).
- (B) Check the signal level of the BPF checkpoint (with the pin 6 RDS input in the range 3 to 6 mVrms or higher).

LA2232, 2232M

ARI Decoder Application Circuit

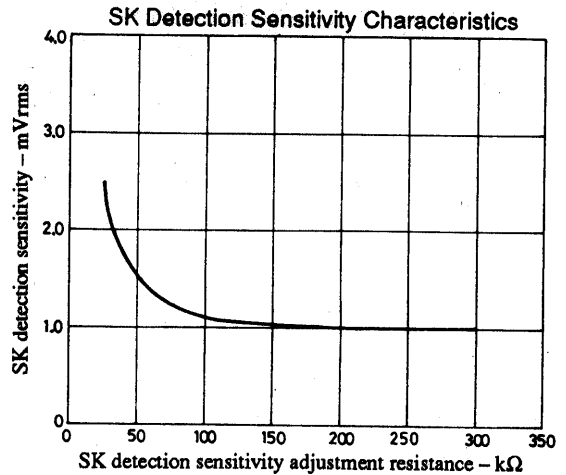
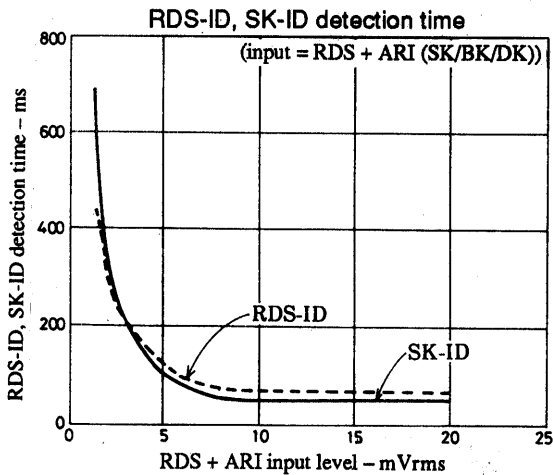
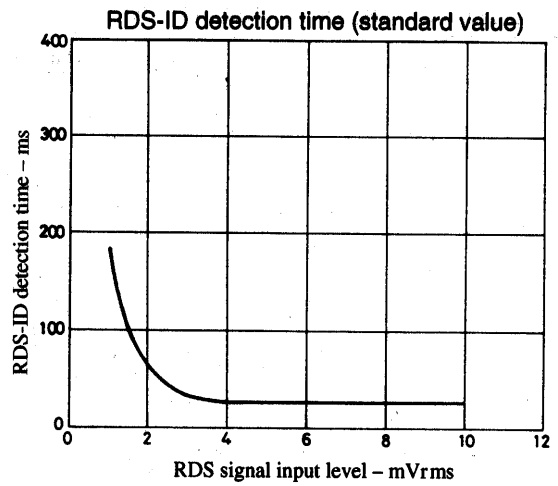
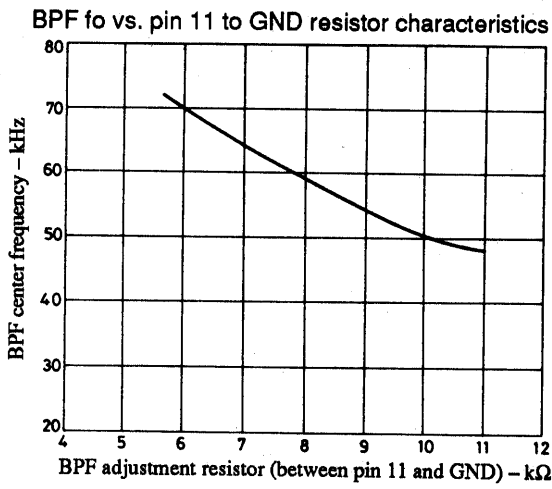
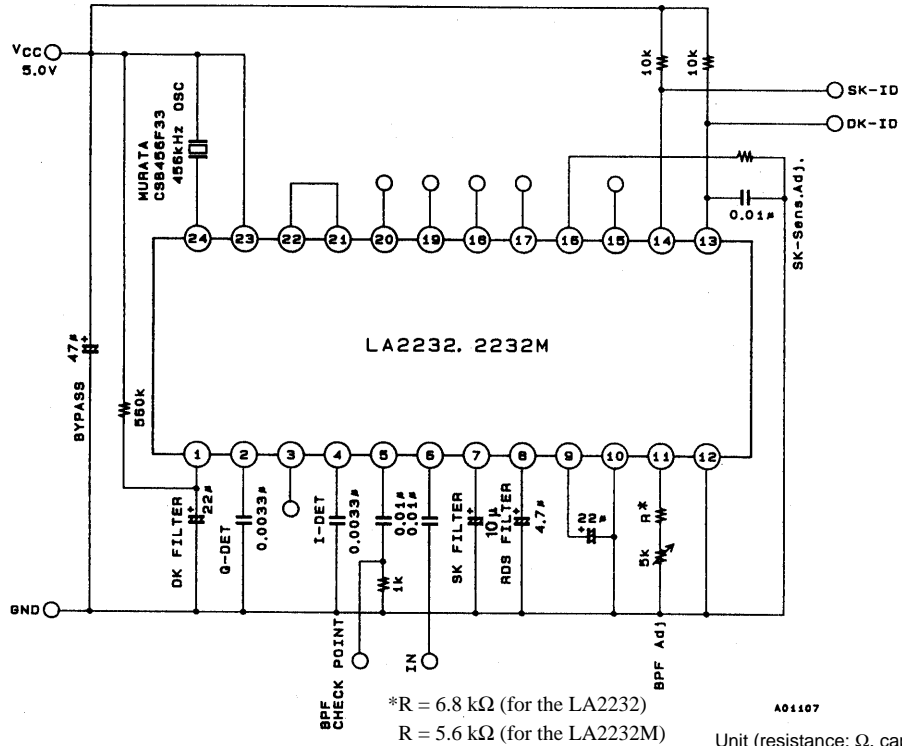

LA2232, 2232M

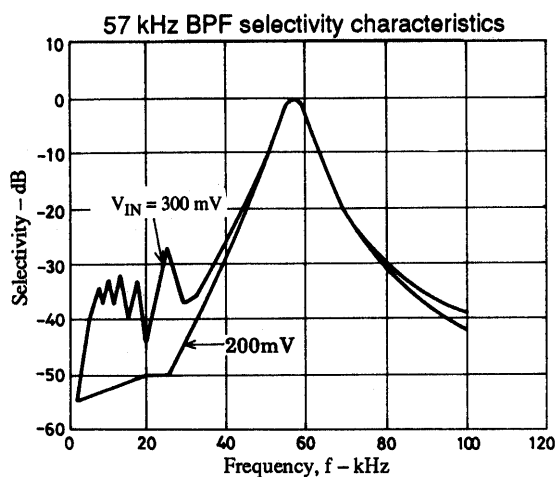

- For the LA2232, an input level of under 300 mVrms on pin 6 is desirable for a 100% FM demodulation output.
- We recommend the use of a pre-high pass filter as shown in the figure below if the 100% FM demodulation output level is over 300 mVrms.

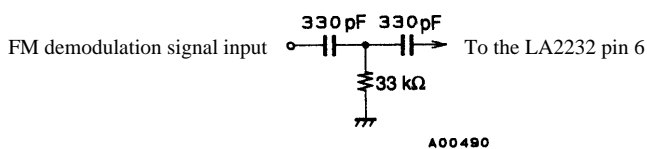

RDS-ID (LA2232), RECEIVE-ID (LC7073) Detection Time
(the RECEIVE-ID indicates synchronization completion).

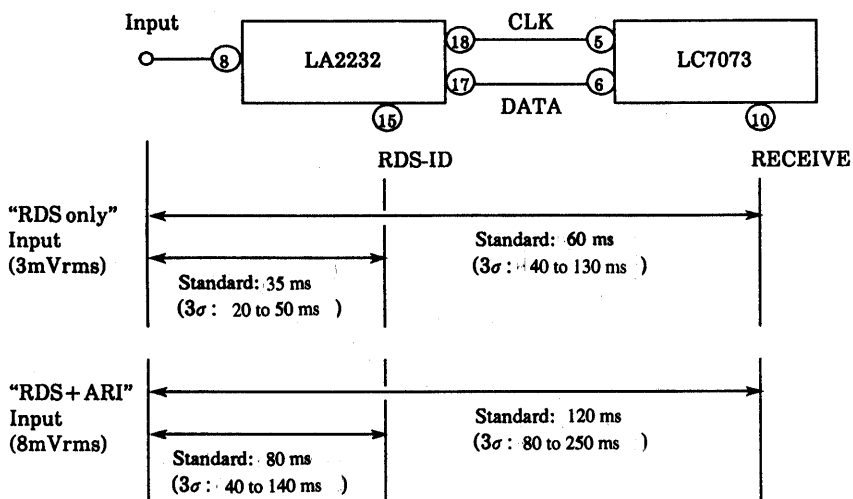

LC7073 RECEIVE-ID detection time (standard value)

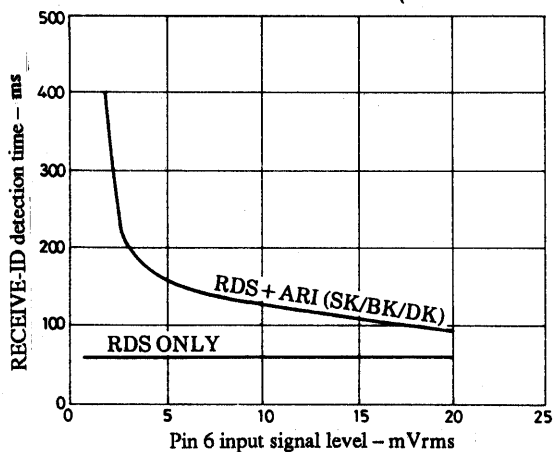

LC7073 RECEIVE-ID detection time (standard value)

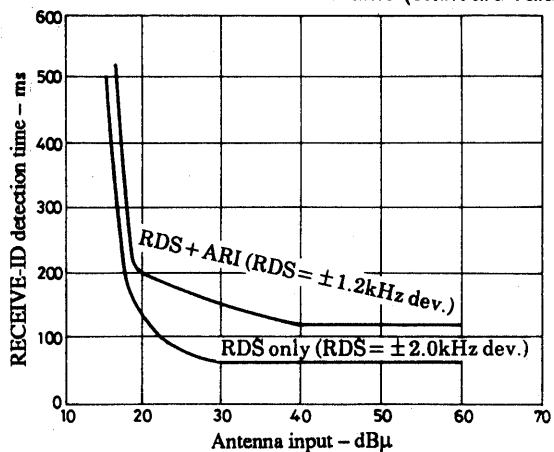

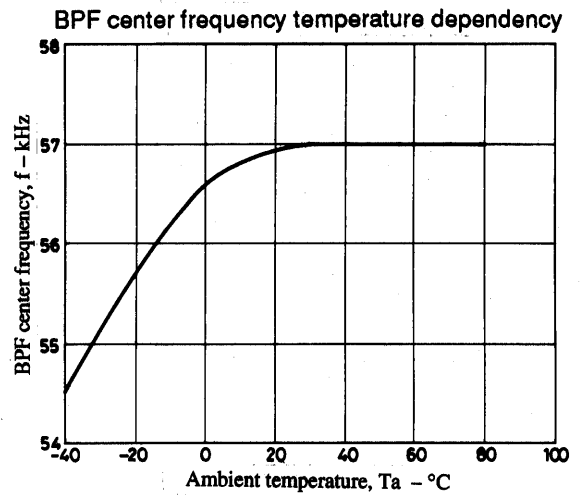
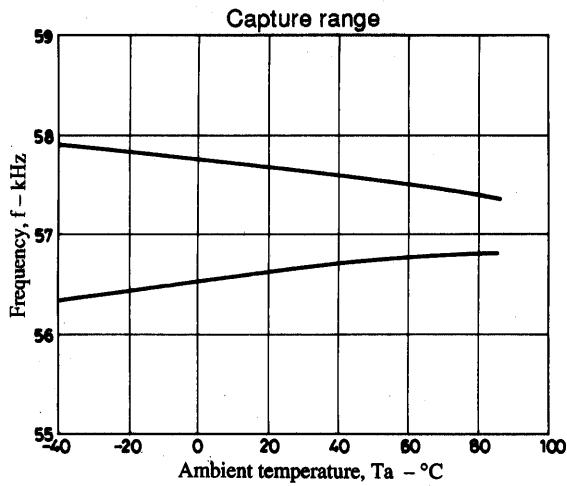
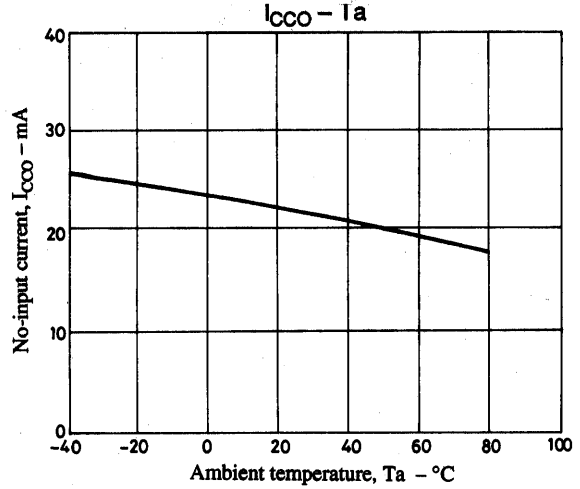
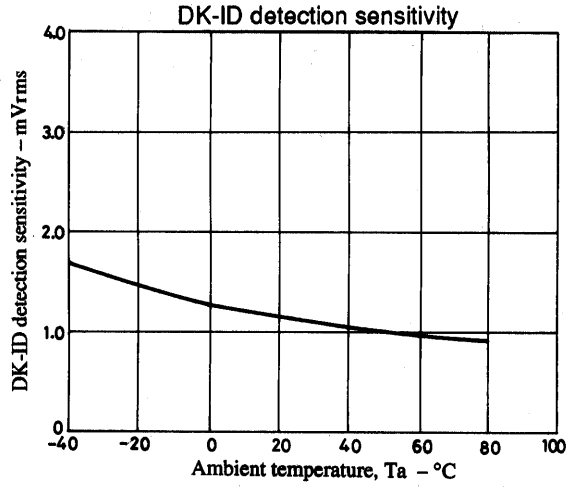
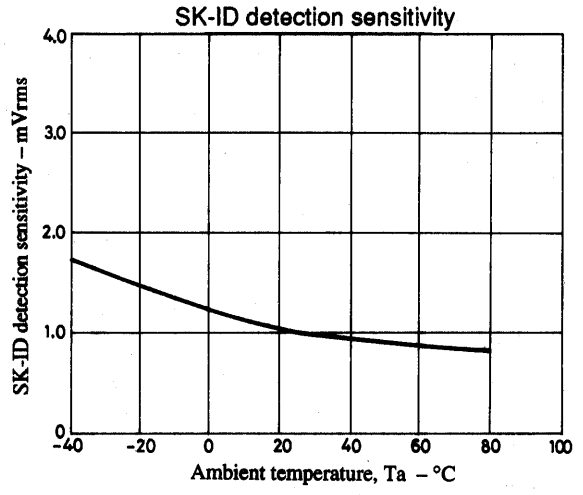
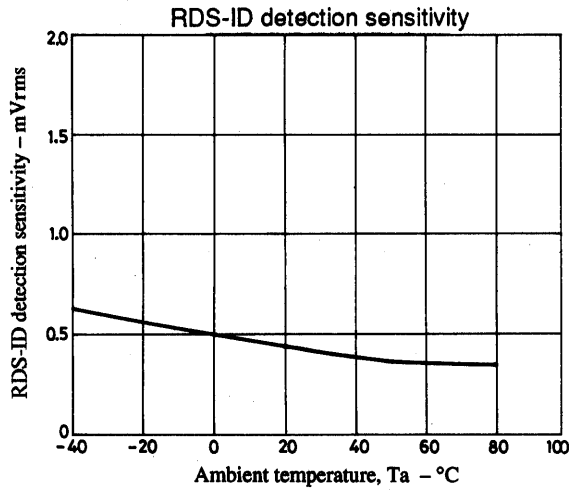

RDS Application IC Lineup

(1)

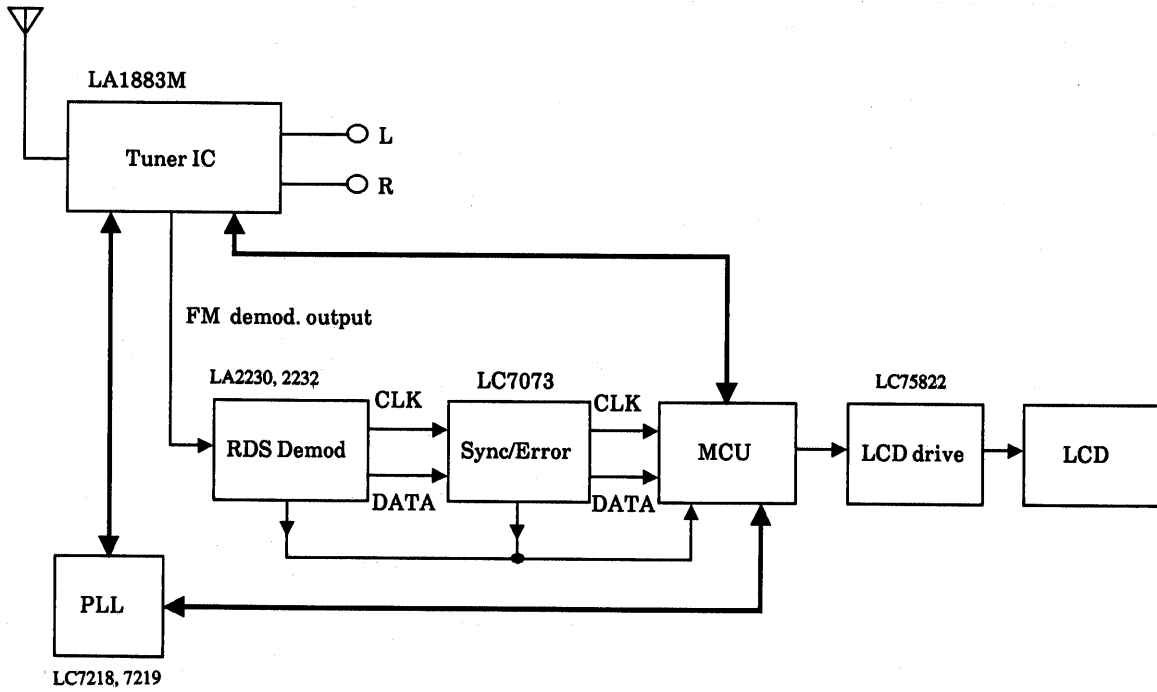

(2)

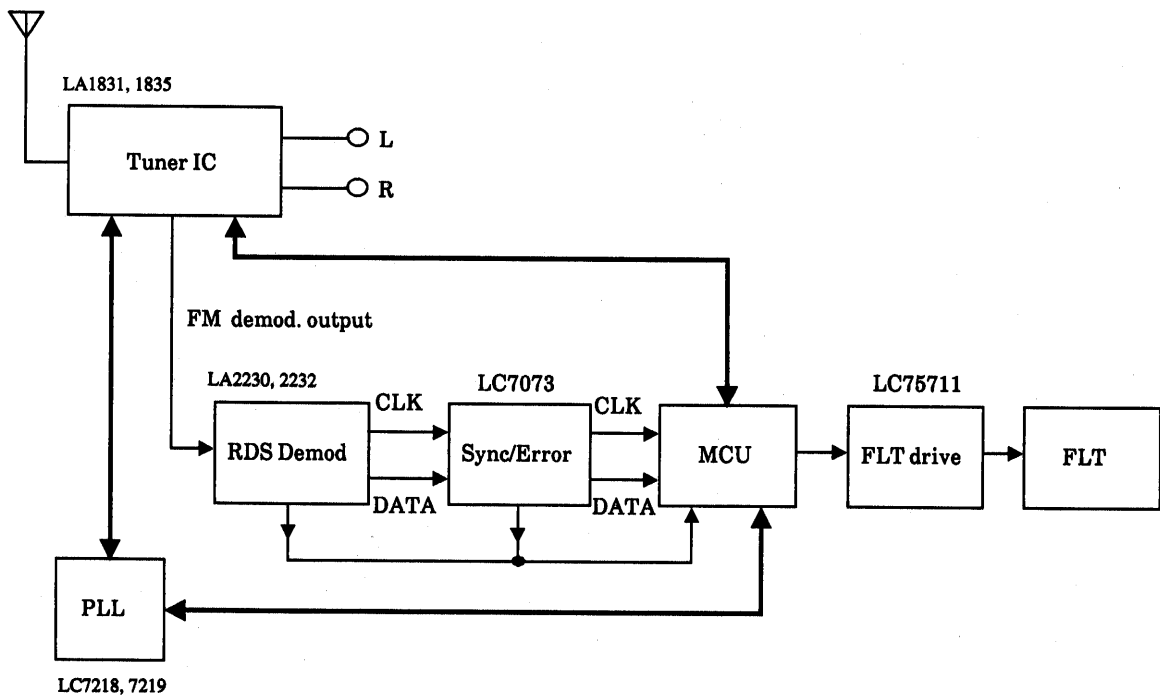

- No products described or contained herein are intended for use in surgical implants, life-support systems, aerospace equipment, nuclear power control systems, vehicles, disaster/crime-prevention equipment and the like, the failure of which may directly or indirectly cause injury, death or property loss.
- Anyone purchasing any products described or contained herein for an above-mentioned use shall:
 - ① Accept full responsibility and indemnify and defend SANYO ELECTRIC CO., LTD., its affiliates, subsidiaries and distributors and all their officers and employees, jointly and severally, against any and all claims and litigation and all damages, cost and expenses associated with such use:
 - ② Not impose any responsibility for any fault or negligence which may be cited in any such claim or litigation on SANYO ELECTRIC CO., LTD., its affiliates, subsidiaries and distributors or any of their officers and employees jointly or severally.
- Information (including circuit diagrams and circuit parameters) herein is for example only; it is not guaranteed for volume production. SANYO believes information herein is accurate and reliable, but no guarantees are made or implied regarding its use or any infringements of intellectual property rights or other rights of third parties.