

Monolithic Linear IC

SANYO

LA4800V

3 V Stereo Headphone Power Amplifier

Overview

The LA4800V is a headphone stereo power amplifier IC that features a high signal-to-noise ratio, high ripple rejection, low distortion and low current consumption, making it ideal for portable CD players.

Functions

- Headphone stereo power amplifier
- Beep tone
- Power switch
- Power mute switch

Features

- 96 dB (typ) high S/N ratio at 7 μ V
- 76 dB (typ) high ripple rejection
- 0.07% (typ) low distortion with $R_L = 16 \Omega$
- 6.2 mA (typ) low current consumption
- Outputs do not require electrolytic capacitors.
- Available in 16-pin SSOPs

Package Dimensions

unit : mm

3178-SSOP16

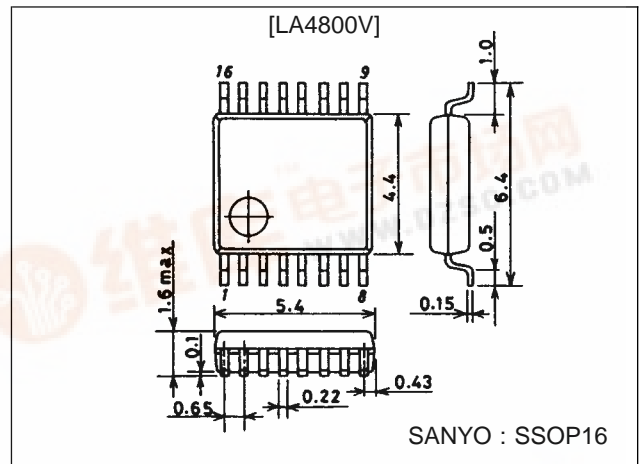

Specifications

Maximum Ratings at Ta = 25°C

Parameter	Symbol	Conditions	Ratings	Unit
Maximum supply voltage	$V_{CC \text{ max}}$		4.5	V
Power dissipation	$Pd \text{ max}$		375	mW
Operating temperature range	$Topr$		-15 to 50	°C
Storage temperature range	$Tstg$		-40 to 150	°C

Recommended Operating Ranges at Ta = 25°C

Parameter	Symbol	Conditions	Ratings	Unit
Supply voltage	V_{CC}		3.0	V
Load resistance	R_L		16 to 32	Ω
Operating supply voltage range	$V_{CC \text{ op}}$		1.8 to 3.6	V



LA4800V

**Operating Characteristics at $T_a = 25^\circ\text{C}$, $V_{CC} = 2.5\text{ V}$, $R_L = 16\ \Omega$, $f = 1\text{ kHz}$ unless otherwise noted.
Values in parentheses indicate $V_{CC} = 3.0\text{ V}$**

Parameter	Symbol	Conditions	min	typ	max	Unit
Quiescent supply current	I_{CCO1}	IC OFF		0.05	1.0	μA
	I_{CCO2}	Mute ON		1.6 (1.65)	3.0	mA
	I_{CCO3}	No input signal		6.2 (6.8)	9.0	mA
Voltage gain	VG	$V_O = -10\text{ dBm}$	10.3	11.8	13.3	dB
Channel balance	V_{RL}	$V_O = -10\text{ dBm}$	-1	0	1	dB
Output power	P_O	$V_{CC} = 3.0\text{ V}$, THD = 10%	15	25		mW
Total harmonic distortion	THD	$V_O = 0.35\text{ V}$		0.075	0.2	%
Output noise voltage	V_{NO}	$R_g = 1\text{ k}\Omega$, DIN AUDIO		7.8	15	μV
Crosstalk	CT	$f = 1\text{ kHz}$, TUN, $V_O = -10\text{ dBm}$	35	45		dB
Ripple rejection	R.R	$V_{CC} = 1.7\text{ V}$, $f = 100\text{ Hz}$, $V_{CR} = -20\text{ dBm}$, TUN = 100 Hz	65	76		dB
Mute attenuation	V_{OFF}	THD = 1%	-80	-96		dB
Beep tone output voltage	$V_{O\text{ BEEP}}$	$V_I = -13.5\text{ dBm}$ (sine wave)	1.5	3.0		mV
Output DC offset voltage	$V_{DC\text{ OFF}}$	$V_I = 0\text{ V}$, $R_g = 1\text{ k}\Omega$	-20	0	20	mV
Power ON current sensitivity	$I_{1\text{ ON}}$	$V_{CC} = 1.7\text{ V}$, $V_5 \cong 1.0\text{ V}$		50	60	μA
Power OFF voltage sensitivity	$V_{1\text{ OFF}}$	$V_{CC} = 1.7\text{ V}$, $V_5 \cong 0.1\text{ V}$	0.5	0.6		V
Mute OFF current sensitivity	$I_{16\text{ OFF}}$	$V_{CC} = 1.7\text{ V}$, $V_5 \cong 1.0\text{ V}$		4.5	6.0	μA
Mute OFF voltage sensitivity	$V_{16\text{ OFF}}$	$V_{CC} = 1.7\text{ V}$	1.0	1.25	1.5	V
Mute ON voltage sensitivity	$V_{16\text{ ON}}$	$V_{CC} = 1.7\text{ V}$		0.9	1.0	V

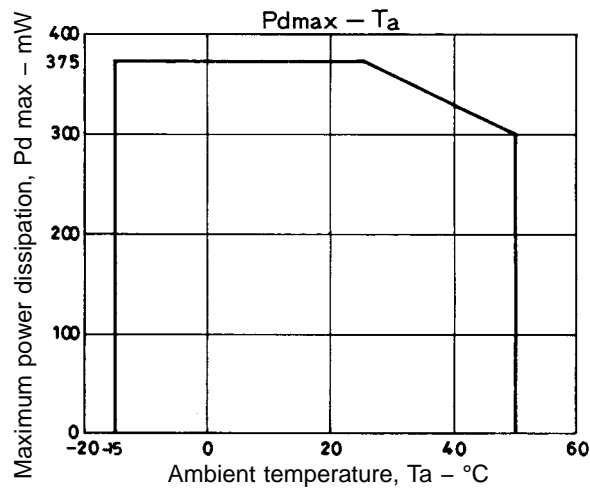

LA4800V

Pin Assignment and Block Diagram

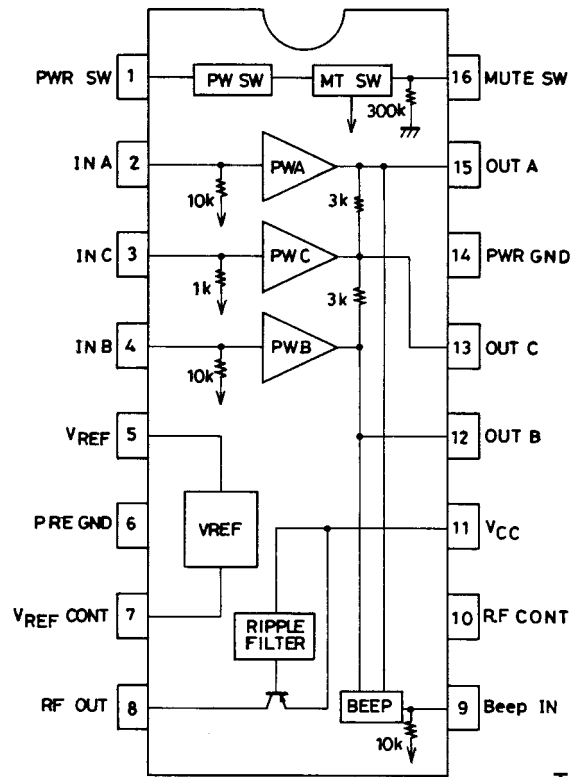

Top view

Unit (resistance: Ω)

Test Circuit

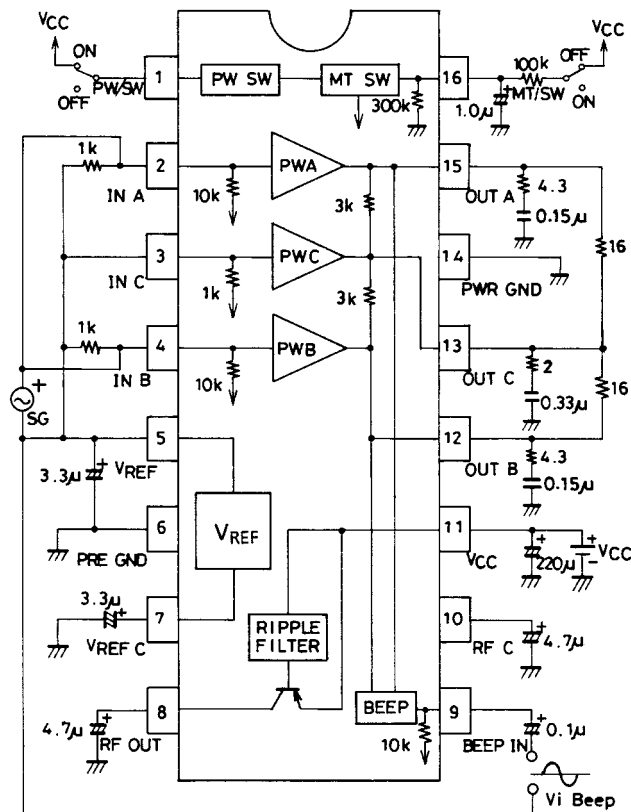

Unit (resistance: Ω , capacitance: F)

LA4800V

Sample Application Circuit

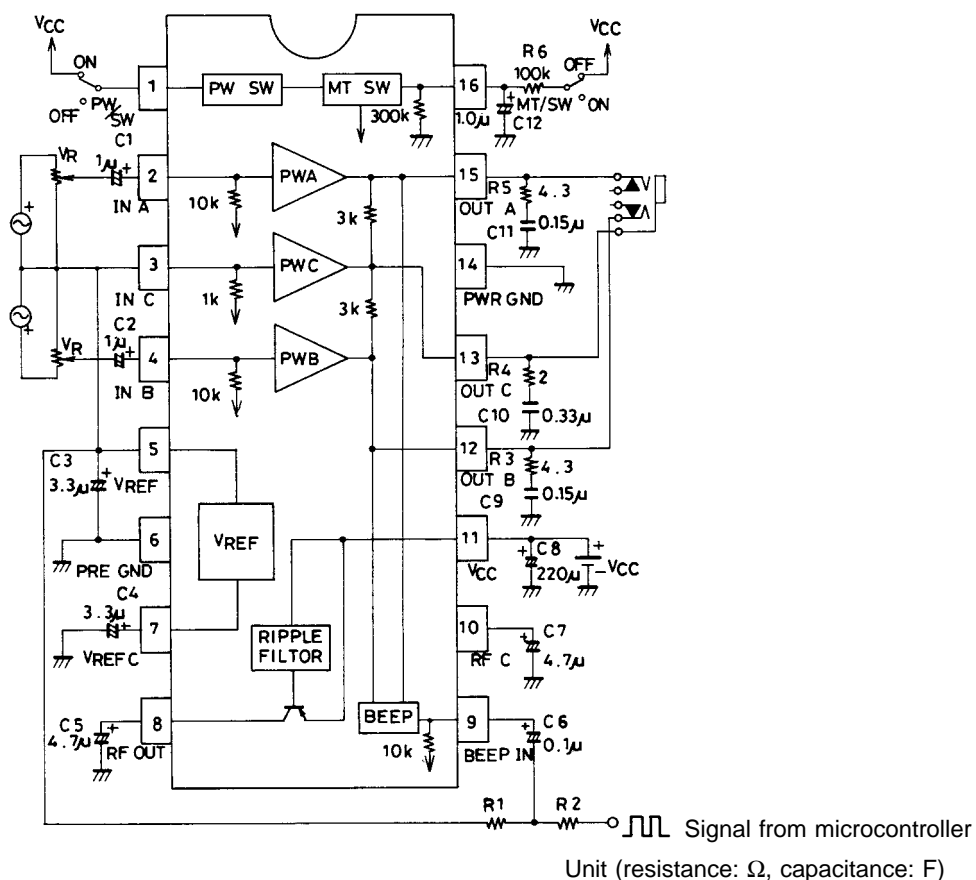

Pin Description

$V_{CC} = 2.5\text{ V}$

Unit (resistance: Ω)

Pin number	Pin name	V_{DC} (V)	Equivalent circuit	Pin description
1	PWR SW	0 to 0.7		Power switch Turns ON the power to the V_{CC} pin.
2	IN A	1.1		Power input pins 10 kΩ input resistance
4	IN B			
3	IN C	1.1		Power amplifier common input pin Usually connected to Vref

Continued on next page.

LA4800V

Continued from preceding page.

Unit (resistance: Ω)

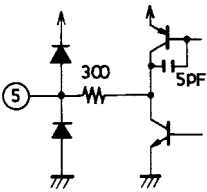
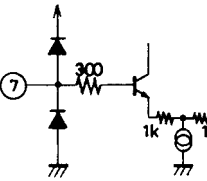
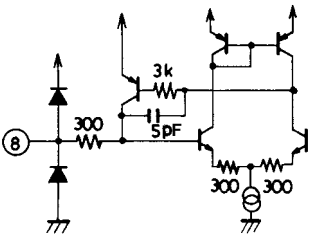
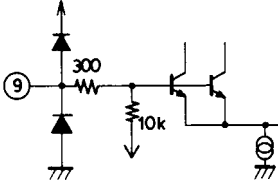
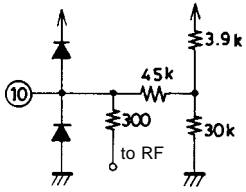
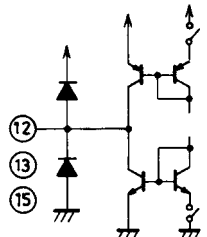
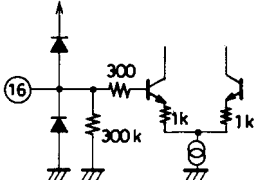
Pin number	Pin name	V _{DC} (V)	Equivalent circuit	Pin description
5	V _{REFOUT}	1.1		1.1 V fixed bias
6	PRE GND			Preamplifier ground
7	V _{REFCONT}	1.1		1.1 V reference control pin
8	RF OUT	2.2		Preset to approximately $V_{CC} \times 0.88$ V
9	Beep IN	1.1		Beep tone input pin Active only when mute is ON.
10	RF CONT	2.2		RF control pin
11	V _{CC}			Power supply
12 13 15	OUT B OUT C OUT A	1.1 1.1 1.1		Power output pins Pin 13 is the headphone center common drive. (No electrolytic capacitors required)
14	PWR GND			Power amplifier ground
16	MUTE SW	0 to 1.85		The mute pin is floating when ON, and tied to V _{CC} through a 100 k Ω when OFF.

LA4800V

External Components Description

Components	Recommended value	Description
C1, C2	1 to 4.7 μ F	Input coupling capacitors
C3, C4	3.3 to 10 μ F	Reference bias (V_{REF}) decoupling capacitors
C5, C4	4.7 to 10 μ F	Ripple filter capacitors. Increasing the capacitance also increases the distortion and the supply rise time at turn ON.
C6	0.1 to 1 μ F	Input coupling capacitor for the beep tone. Choose a value that does not attenuate the beep tone signal.
C8	220 μ F	Supply line coupling capacitor
C9, C10, C11	0.22 to 0.47 μ F	Oscillation damping capacitors. Film capacitors are recommended.
C12	0.1 to 1.0 μ F	Mute time setting capacitor. See the description in the Operating Notes.
R1, R2		Beep tone input signal adjustment resistors. Follow the manufactures instructions.
R3, R4, R5	0.5 to 4.3 Ω	Power amplifier oscillation damping resistors.
R6	100 k Ω	Mute OFF pin 16 bias setting resistor. The internal 300 k Ω resistor and this 100 k Ω resistor together set the mute switch (pin 16) threshold.

Operating Notes

Beep tone operating principle

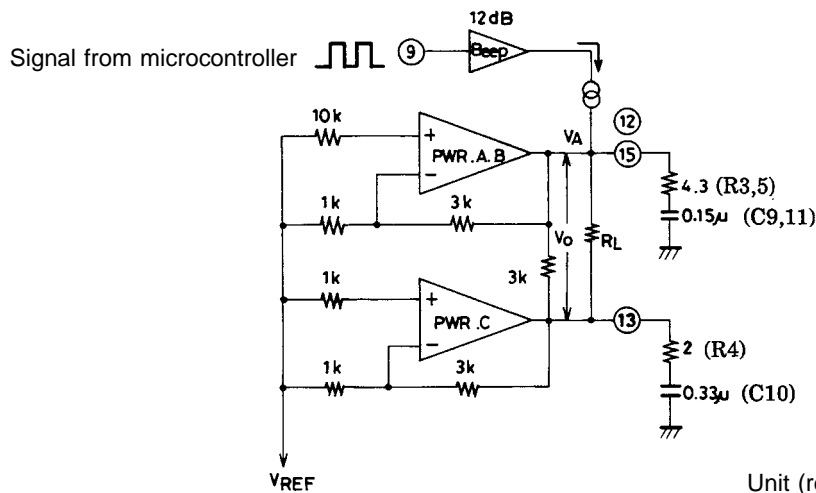

The design of the above when mute is ON (pin 16 open) is as follows:

The output voltage V_O as function of R_L is

$$V_O = \frac{R_L}{R_L + 3k + 1k} \times V_A$$

For example, if $R_L = 16 \Omega$ and $V_A = 0.5 \text{ V}$ (V_A is the adjusted input voltage on pin 9),

$$V_O = \frac{16\Omega}{16\Omega + 3k + 1k} \times 0.5 \cong 2 \text{ mV}$$

The beep tone output voltage V_O is determined by the above equation. However, the oscillation damping RC components are connected to the PWR output and hence these RC components will also influence the actual value of V_O . When using the beep tone, the impedance of C10, connected to the common output (pin 13), must be greater than the impedance of C9 and C11, i.e. C10 must be greater than C9 and C11.

LA4800V

Mute time adjustment

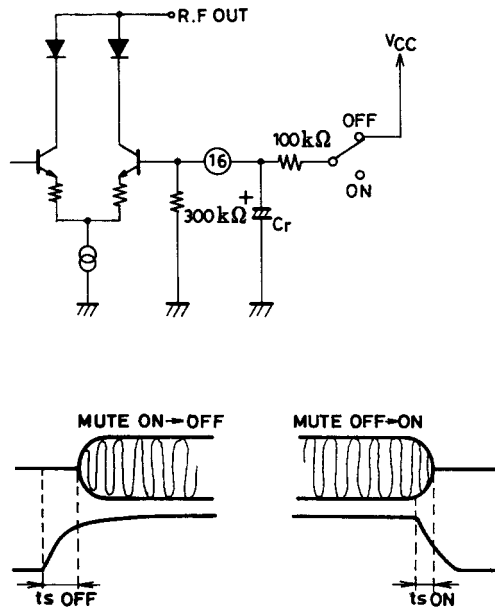

The mute ON/OFF switching waveforms are shown in the figure above. The settling time t_S is determined by the capacitor C_r connected to pin 16. The recommended value of C_r is 1 μF . If the value used is less than 1 μF , pop noise will increase.

The setting time for different values of C_r are shown in the table below.

C_r (μF)	$t_{S \text{ OFF}}$ (ms)	$t_{S \text{ ON}}$ (ms)
0.1	15	3.2
1.0	150	30
2.2	300	56

LA4800V

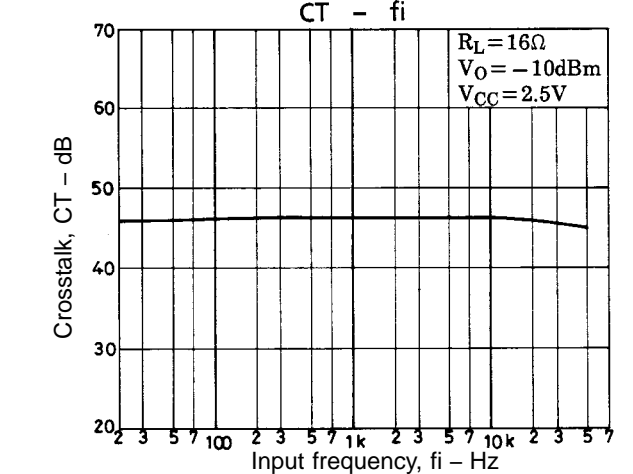
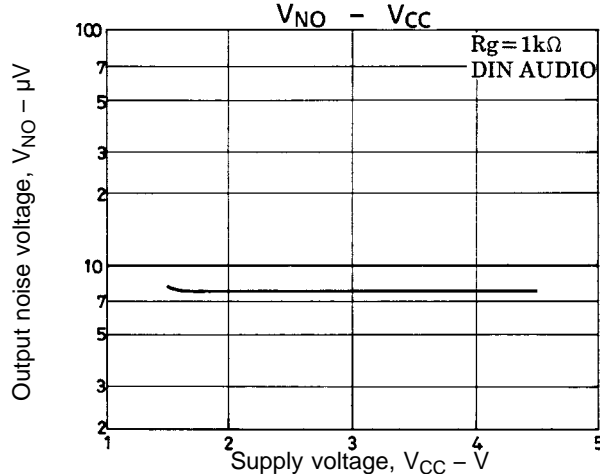
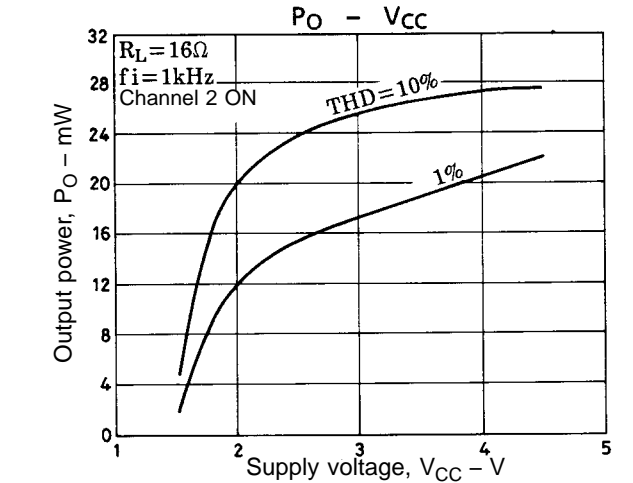
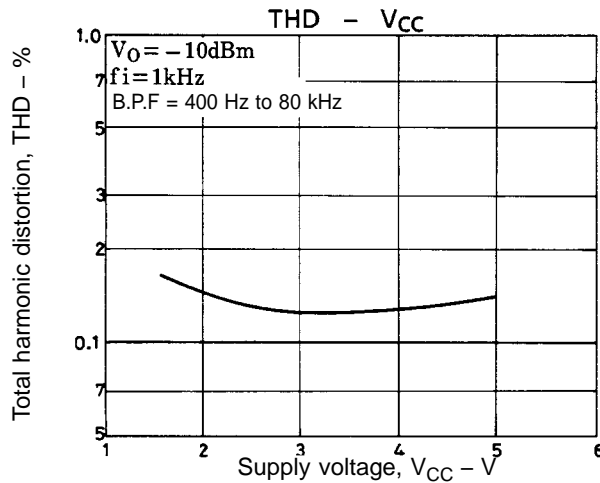
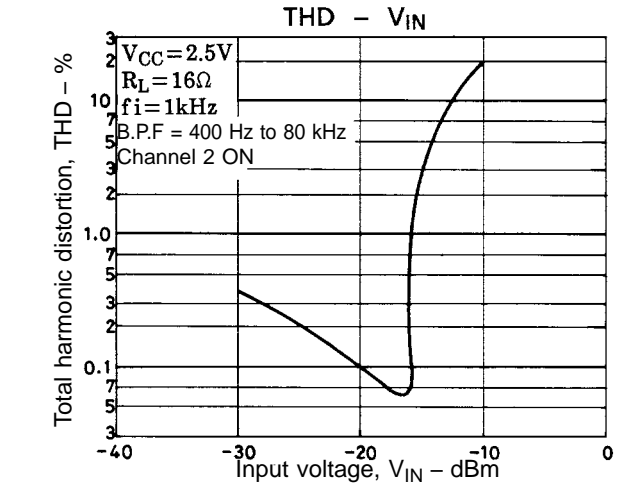
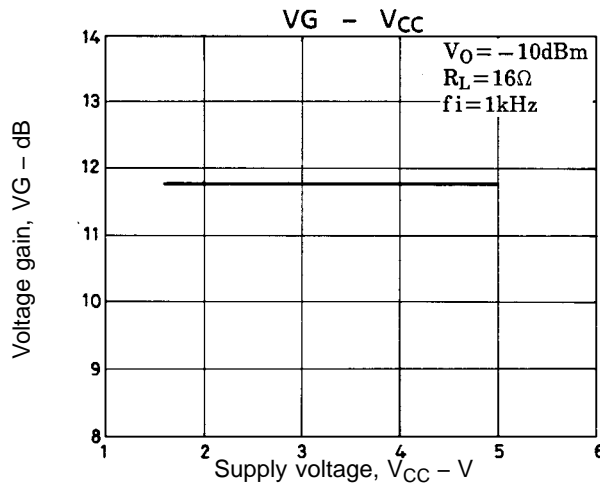
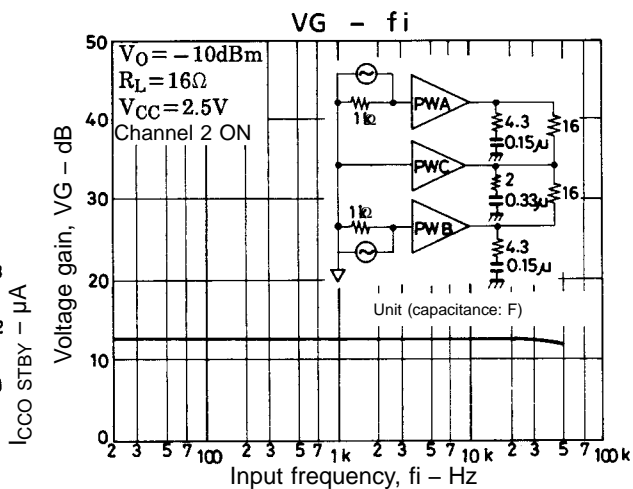
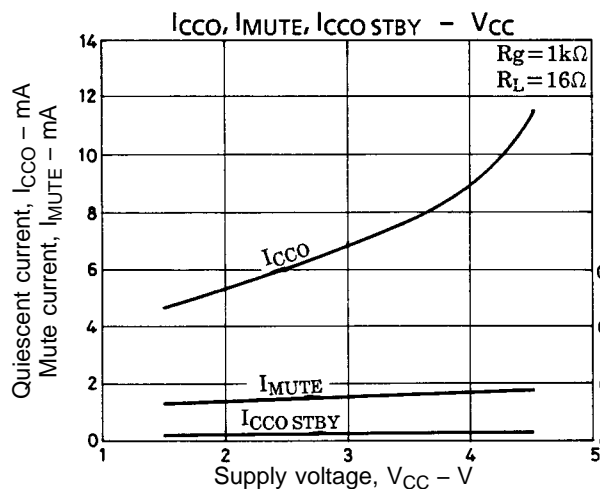

LA4800V

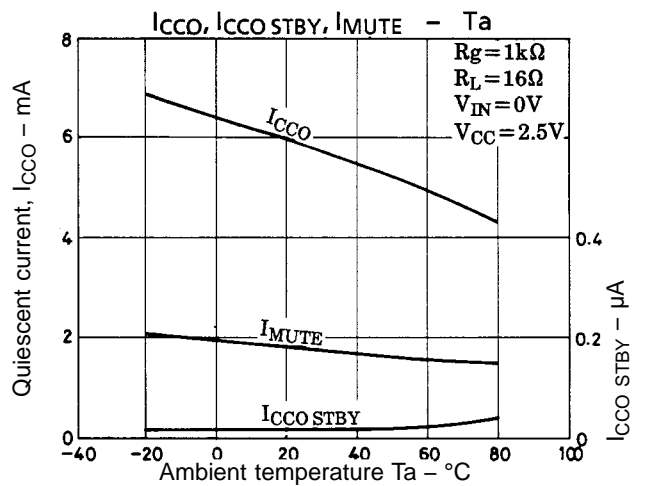
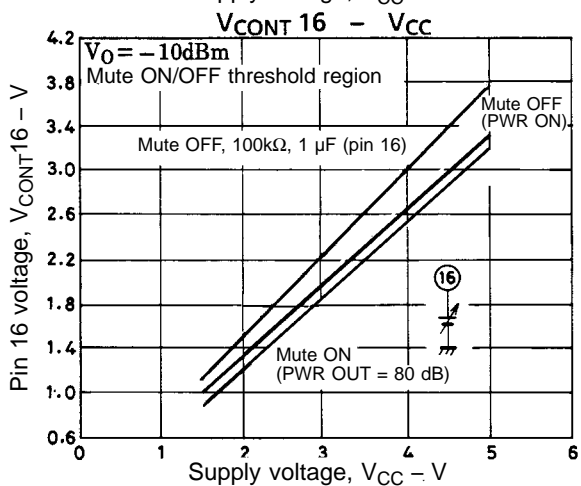
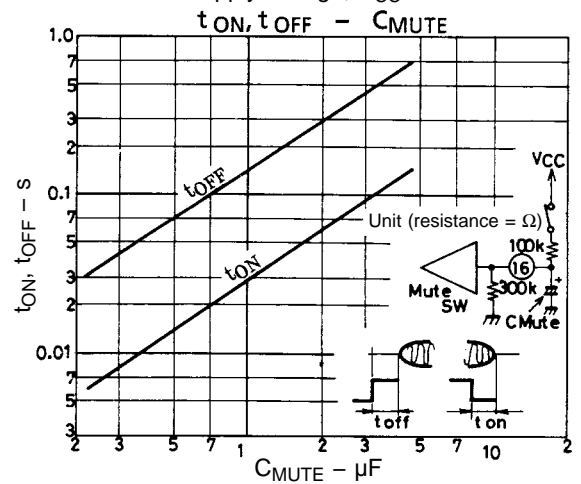
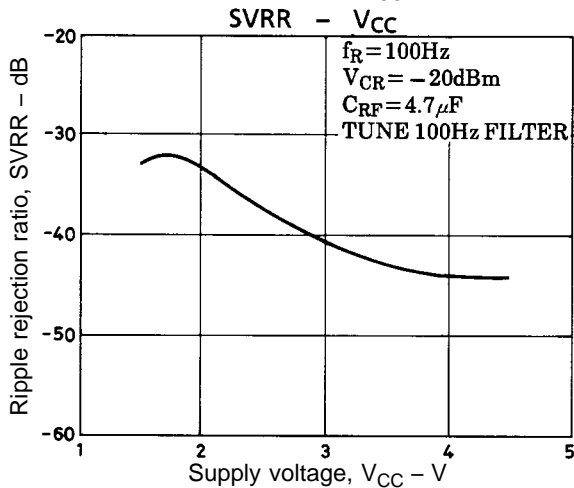
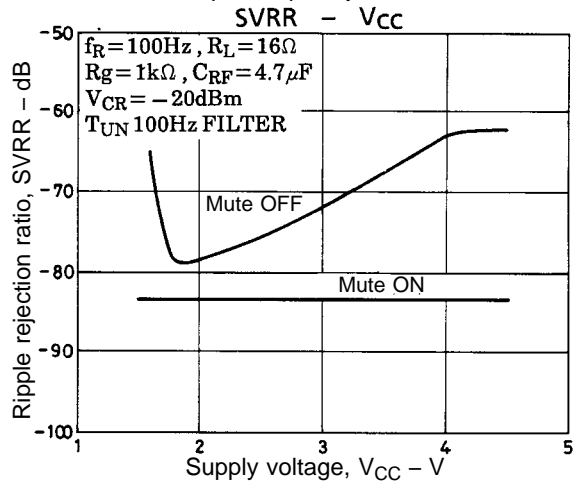
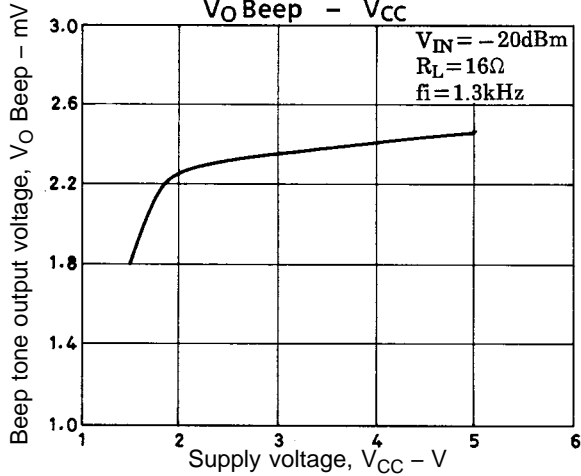
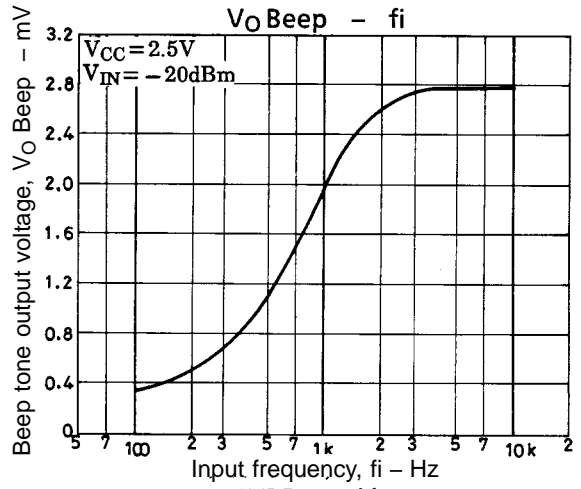
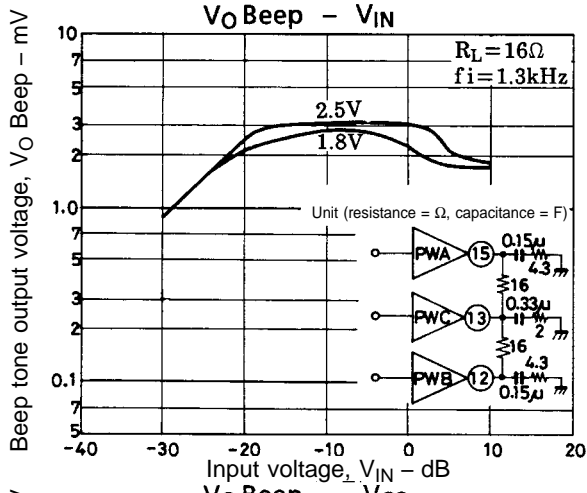

LA4800V

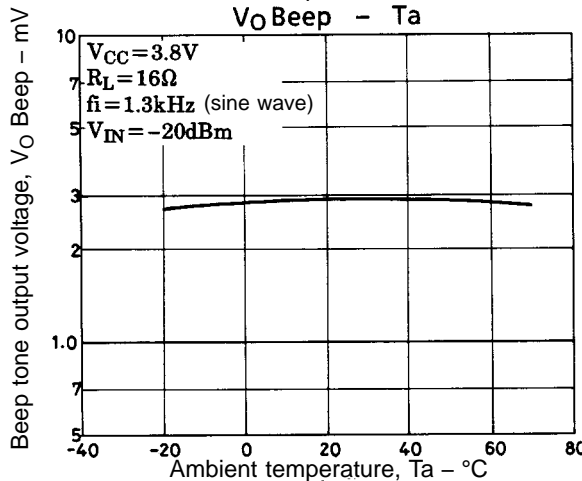
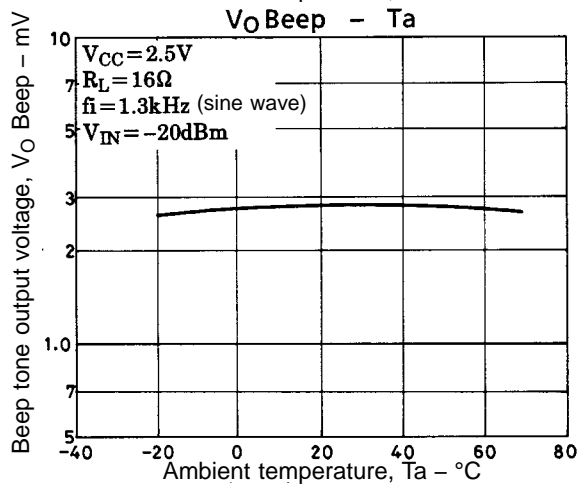
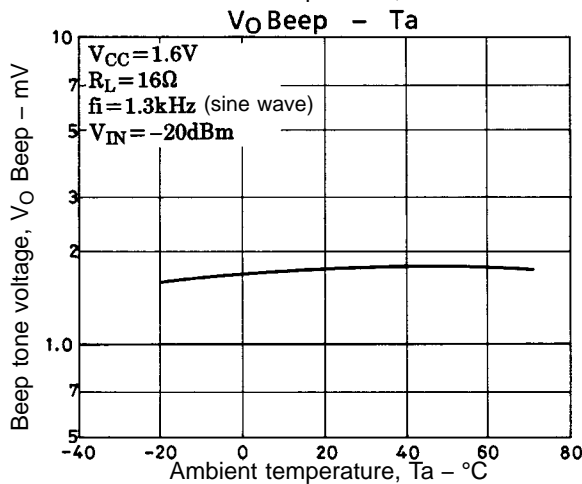
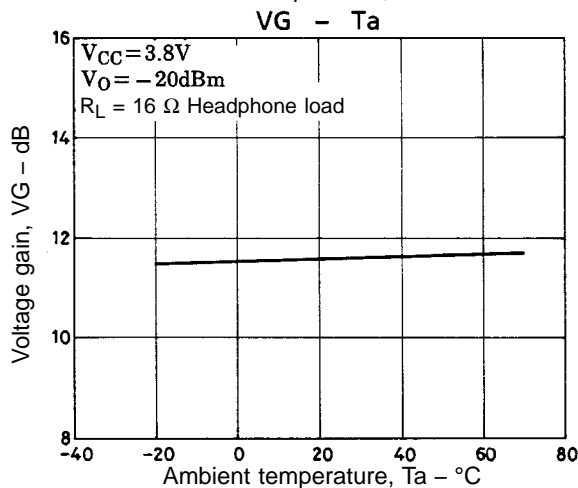
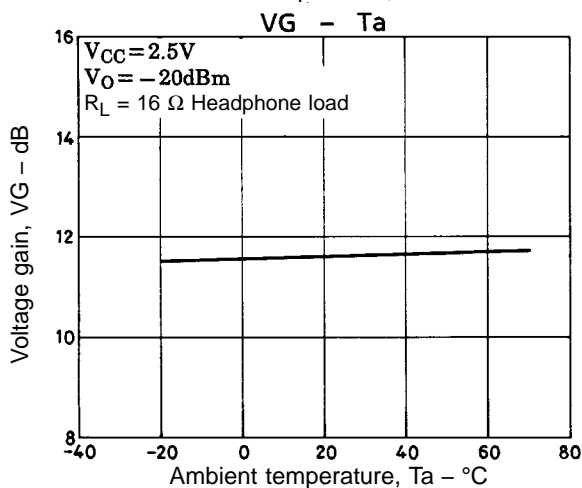
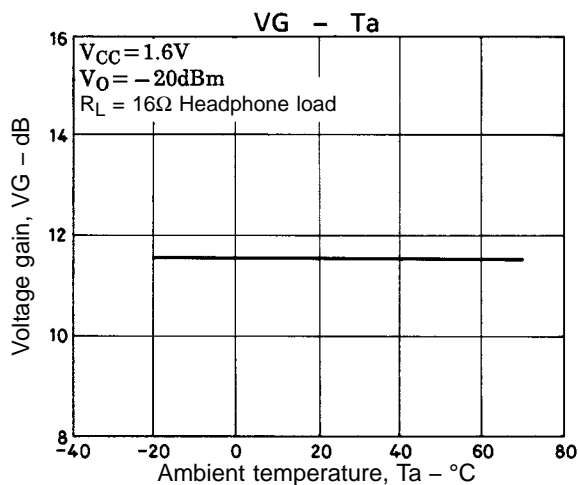
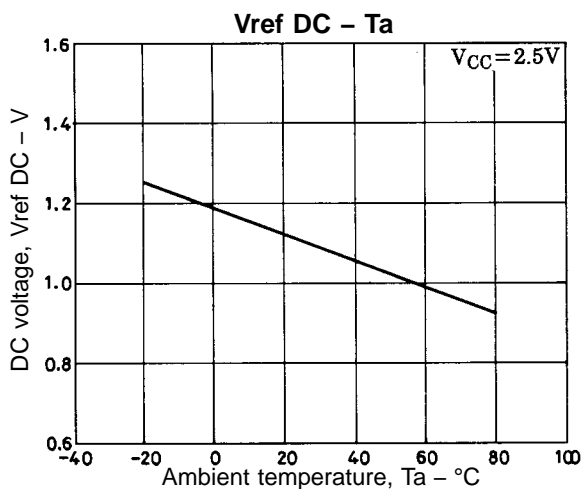

LA4800V

- No products described or contained herein are intended for use in surgical implants, life-support systems, aerospace equipment, nuclear power control systems, vehicles, disaster/crime-prevention equipment and the like, the failure of which may directly or indirectly cause injury, death or property loss.
- Anyone purchasing any products described or contained herein for an above-mentioned use shall:
 - ① Accept full responsibility and indemnify and defend SANYO ELECTRIC CO., LTD., its affiliates, subsidiaries and distributors and all their officers and employees, jointly and severally, against any and all claims and litigation and all damages, cost and expenses associated with such use:
 - ② Not impose any responsibility for any fault or negligence which may be cited in any such claim or litigation on SANYO ELECTRIC CO., LTD., its affiliates, subsidiaries and distributors or any of their officers and employees jointly or severally.
- Information (including circuit diagrams and circuit parameters) herein is for example only; it is not guaranteed for volume production. SANYO believes information herein is accurate and reliable, but no guarantees are made or implied regarding its use or any infringements of intellectual property rights or other rights of third parties.