

Ordering number : ENN6657

Monolithic Linear IC



LA4802T

Headphone Stereo Power Amplifier

Overview

The LA4802T is a headphone stereo power amplifier for portable CD and MD players. It features a high signal-to-noise ratio, a high ripple rejection ratio, low distortion, and low current drain.

Functions

- Headphone stereo power amplifier
- Power switch
- Muting switch
- Beep tone function control input pin (The beep tone function can be used regardless of whether the mute function is on or off.)

Features

- High signal-to-noise ratio (100 dB typical at 7.5 μ V)
- High ripple rejection ratio (70 dB typical)
- Low current drain (950 μ A typical)
- On-chip bass compensation circuit (Compensates for bass frequency attenuation due to the output capacitors and achieves flat frequency characteristics.)
- Ultraminiature package (MSOP-20)

Package Dimensions

unit: mm

3262-MSOP20

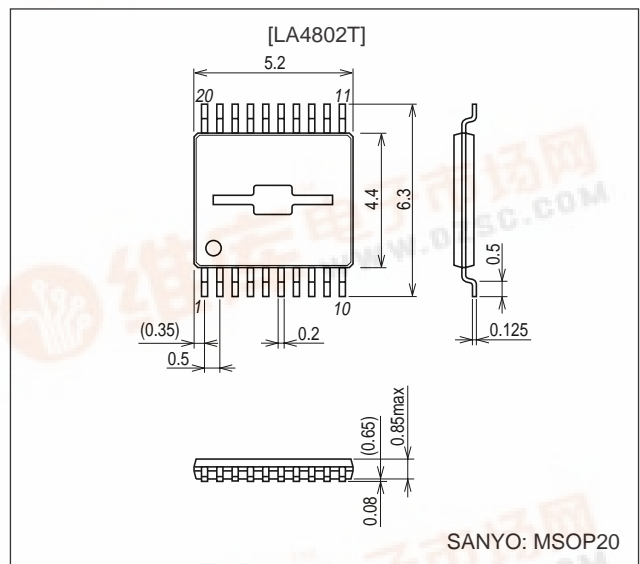

Specifications

Maximum Ratings at Ta = 25°C

Parameter	Symbol	Conditions	Ratings	Unit
Maximum supply voltage	V _{CC} max		4.5	V
Allowable power dissipation	Pd max	When mounted, Ta = 80°C	375	mW
Operating temperature	T _{opr}		-20 to +80	°C
Storage temperature	T _{stg}		-40 to +150	°C

- Any and all SANYO products described or contained herein do not have specifications that can handle applications that require extremely high levels of reliability, such as life-support systems, aircraft's control systems, or other applications whose failure can be reasonably expected to result in serious physical and/or material damage. Consult with your SANYO representative nearest you before using any SANYO products described or contained herein in such applications.
- SANYO assumes no responsibility for equipment failures that result from using products at values that exceed, even momentarily, rated values (such as maximum ratings, operating condition ranges, or other parameters) listed in products specifications of any and all SANYO products described or contained herein.



LA4802T

Operating Conditions at Ta = 25°C

Parameter	Symbol	Conditions	Ratings	Unit
Recommended supply voltage	V _{CC}		2.4	V
Operating supply voltage range	V _{CC OP}		1.8 to 3.6	V
Recommended load resistance	R _L		16 to 32	Ω

Electrical Characteristics at Ta = 25°C, V_{CC} = 2.4 V, f_{IN} = 1 kHz, R_L = 16 Ω

Item	Symbol	Conditions	Ratings			Unit
			min	typ	max	
Quiescent current	I _{CCO1}	Current when ST is off (with L.B. on and muting off)		0.05	1	μA
	I _{CCO2}	Current when muting is on (with ST on and L.B. on)		530	900	μA
	I _{CCO3}	Current when ST is on (with L.B. on and muting off)		950	1500	μA
Operating current drain	I _{CC1}	P _O = 0.1 mW (With 2 channels driven)		3.2	3.7	mA
Voltage gain	VG	V _O = -10 dBm	6.8	7.8	8.8	dB
Channel balance	ΔVG	V _O = -10 dBm	-1	0	+1	dB
Output power	P _O	THD = 10%	25	38		mW
Total harmonic distortion	THD	V _O = -8 dBm, 20 kHz LPF		0.03	0.1	%
Output noise voltage	V _{NO}	R _g = 10 kΩ, IHF A		-100	-90	dBm
Crosstalk	CT	T _{UN} 1kHz, V _O = -10 dBm	70	80		dB
Ripple rejection ratio	SVRR	f _r = 100 kHz, V _r = -20 dBm, T _{UN} 100Hz	60	70		dB
Peak output voltage	V _O BEEP	V _{IN} = 2.4 V _{p-p} , f = 1 kHz, MUTE OFF	1.0	2.7		mV
Muting attenuation	V _{OFF}	THD = 1%, T _{UN} 1kHz	-100	-120		dB
Power on voltage sensitivity	V _{1 ON}	Power on threshold voltage	1.6			V
Power off voltage sensitivity	V _{1 OFF}	Power off threshold voltage			0.5	V
Mute on voltage sensitivity	V _{20 ON}	Muting on threshold voltage	1.4			V
Mute off voltage sensitivity	V _{20 OFF}	Muting off threshold voltage			0.5	V
Boost on voltage sensitivity	V _{4 ON}	Boost on threshold voltage			0.5	V
Boost off voltage sensitivity	V _{4 OFF}	Boost off threshold voltage	1.4			V
Ta = 25°C, V _{CC} = 2.7 V, f _{IN} = 1 kHz, R _L = 47 kΩ (Characteristics when used as a line output), L.B OFF						
Operating current drain	I _{CC2}	V _O = 0 dBm (With 2 channels driven)		1.5	2.0	mA
Total harmonic distortion	THD2	V _O = 0 dBm, 20 kHz LPF		0.005	0.05	%
Output noise voltage	V _{NO2}	R _g = 10 kΩ, IHF A		-100	-90	dBm
Crosstalk	CT2	T _{UN} 1kHz, V _O = -10 dBm	80	90		dB
Ripple rejection ratio	SVRR2	f _r = 100 kHz, V _r = -20 dBm, T _{UN} 100Hz	65	78		dB

Switch Threshold Voltages and Pin Influx Currents

- Standby switch (pin 1)

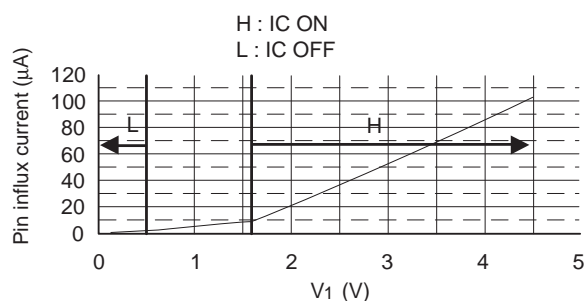

- Mute switch (pin 20), boost switch (pin 4)

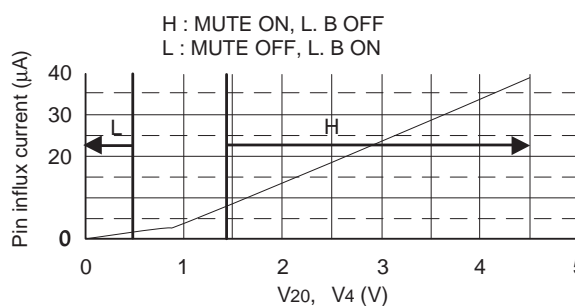

Notes on the Beep Tone Output Function

- This function provides a beep tone output under control of the system microcontroller.
- The beep tone can be provided regardless of the on/off state of the muting function.
- The recommended beep input signal level is a square wave with $V_{IN} = 2.4 V_{p-p}$. When the muting function is off, the beep tone output, $V_{O\text{BEEP}}$, will be 2.7 V rms, and when muting is on, the output will be 1.3 Vrms.

Notes on the Muting Time

- The muting on time and the muting off time can be modified by changing the value of the external capacitor C4 connected to pin 6. The recommended value for C4 is 1 μF . With lower values, impulse noise levels will increase.
- The on/off times will change as shown below when the value of C4 is varied.

C4	On time	Off time
0.1 μF	0.2 ms	9 ms
0.47 μF	1 ms	40 ms
1 μF	2 ms	80 ms

- We recommend operating the mute switch at the same time as the power on/off switch (pin 1) to minimize impulse noise at power on and off.

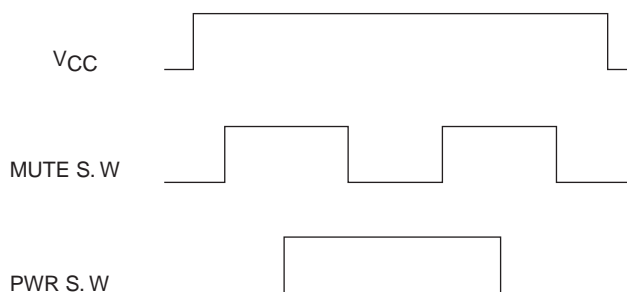

A13553

Notes on the Bass Compensation Circuit

- When the headphone load is connected to the output, the low frequencies will be attenuated due to the output capacitors. This circuit compensates for that attenuation and creates frequency response characteristics that are close to flat.
- This function can be turned on or off from pin 4. When used as a line output, the load will be less than 16 Ω , and the bass frequency characteristics will be somewhat increased. Therefore we recommend leaving the bass compensation circuit off in this case.

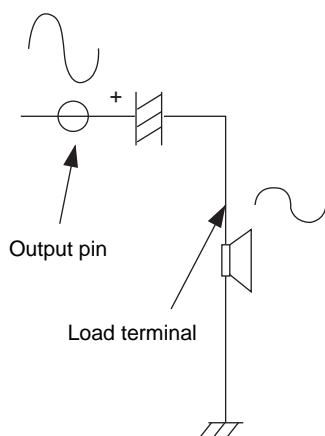

A13554

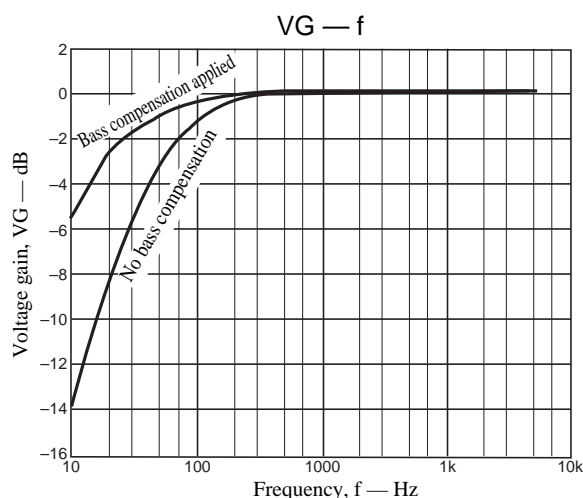

LA4802T

Block Diagram and Test Circuit

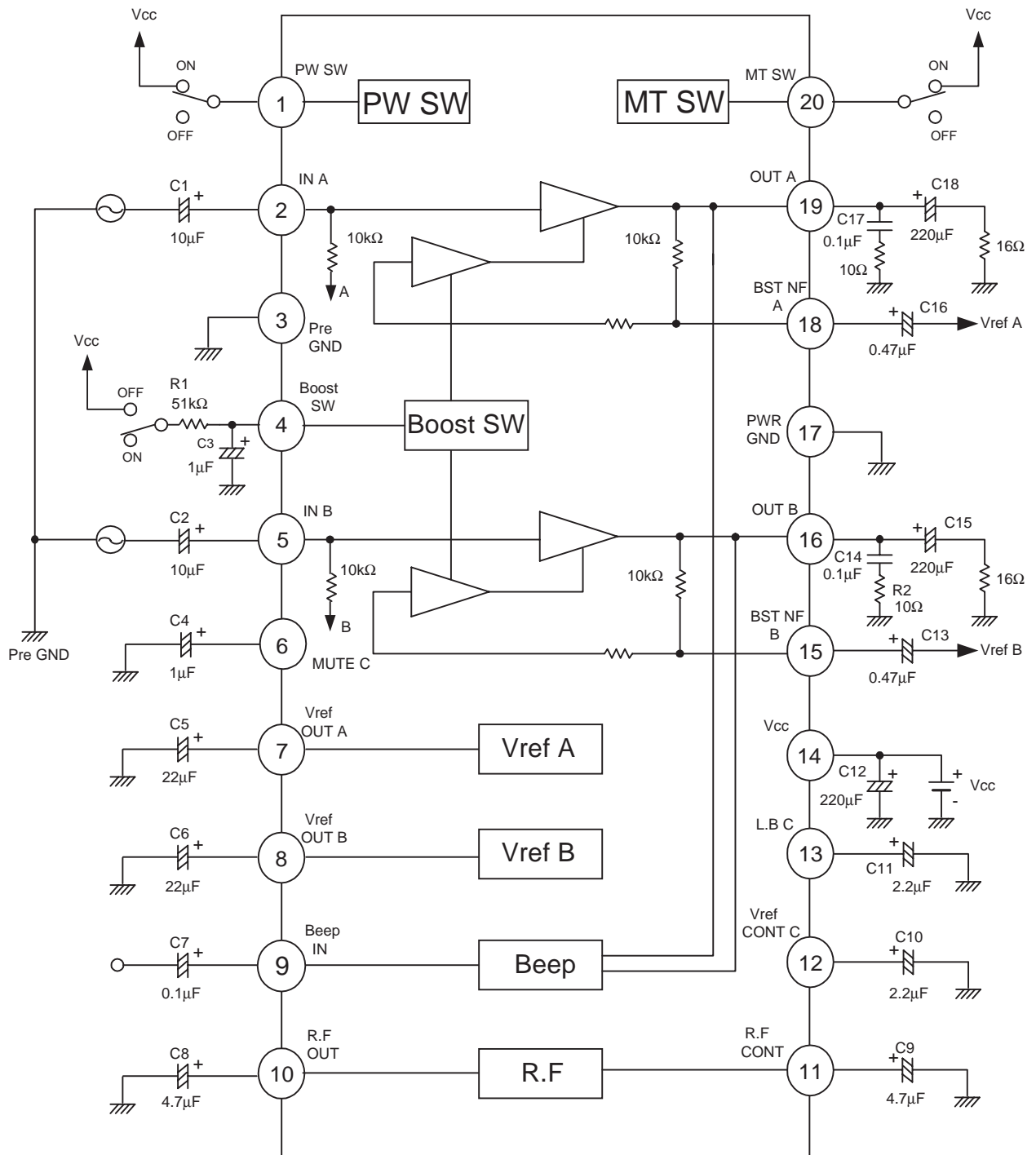

* Package : MSOP-20

Top view

External Components (Values in parentheses are recommended values.)

- C1, C2 (1 to 10 μF)
Input coupling capacitors.
- C3 (0.47 to 2.2 μF)
Boost switch on/off impulse noise reduction capacitor.
- C4 (1 μF)
Mute switch on/off impulse noise reduction capacitor.
- C5, C6 (10 to 22 μF)
Reference bias (V_{REF}) decoupling capacitors.
- C7 (0.1 to 1 μF)
Beep input coupling capacitor. Be careful not to attenuate the beep tone signal.
- C8, C9 (2.2 to 4.7 μF)
Ripple filter capacitors.
- C10 (2.2 to 4.7 μF)
Reference bias (V_{REF}) decoupling capacitors.
- C11 (1 to 2.2 μF)
Boost switch on/off impulse noise reduction capacitor.
- C12 (220 μF)
Power supply line decoupling capacitor.
- C13, C16 (0.47 μF)
Low pass filter capacitor in the bass boost circuit. The amount of bass boost depends on the value of this capacitor.
- C14, C17 (0.1 μF)
Output oscillation prevention capacitors. We recommend using Mylar capacitors. Since the oscillation stability varies depending on the PCB layout and other factors, we recommend a value of at least 0.1 μF for these capacitors.
- C15, C18 (220 to 470 μF)
Output capacitors. Low band attenuation increases with lower capacitances.
- R1 (24 to 51 $\text{k}\Omega$)
Smoothing resistor for the boost switch on/off transition. Note that using a smaller value will increase the idling current when the boost switch is off.
- R2, R3 (10 Ω)
Output oscillation prevention resistors.

LA4802T

Application that does not use the line outputs (The bass compensation circuit is always on.)

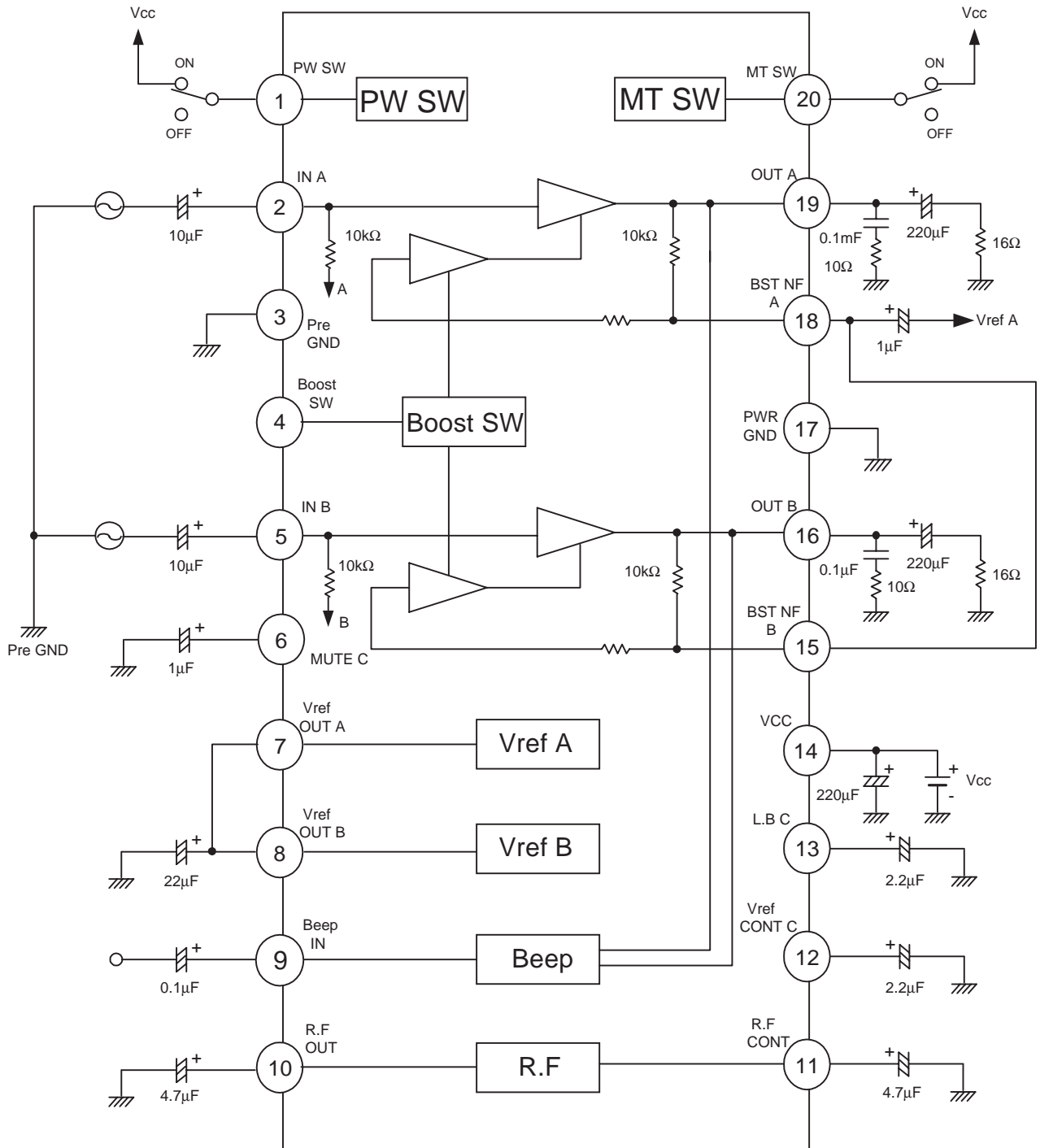

* Package : MSOP-20

Top view

LA4802T

Pin Descriptions

Pin No.	Pin name	Pin voltage (V)	Pin description	Equivalent circuit
1	POWER SW		<ul style="list-style-type: none"> • IC on/off switch • 0 to 0.5 V: IC off • 1.4 to 4.5 V: IC on 	
2 5	POWER IN	1.21	<ul style="list-style-type: none"> • Power input 	
3	PRE GND			
4	BOOST SW		<ul style="list-style-type: none"> • Bass compensation circuit on/off switch • 0 to 0.5 V: Boost on • 1.4 to 4.5 V: Boost off 	
6	MUTE C	1.27	<ul style="list-style-type: none"> • Connection for the mute switch on/off impulse noise reduction capacitor 	
7 8	V _{REF} OUT	1.21	<ul style="list-style-type: none"> • V_{REF} amplifier reference 	

Continued on next page.

LA4802T

Continued from preceding page.

Pin No.	Pin name	Pin voltage (V)	Pin description	Equivalent circuit
9	BEEP IN	1.21	• Beep input	<p style="text-align: right;">A13735</p>
10	RF OUT	2.15	• Ripple filter output	<p style="text-align: right;">A13736</p>
11	RF CONT	2.15	• Ripple filter reference	<p style="text-align: right;">A13737</p>
12	V _{REF} CONT C	1.21	• V _{REF} amplifier reference	<p style="text-align: right;">A13738</p>
13	L. B C	1.33	• Connection for the bass compensation circuit switch on/off impulse noise reduction capacitor	<p style="text-align: right;">A13739</p>
14	V _{CC}			

Continued on next page.

LA4802T

Continued from preceding page.

Pin No.	Pin name	Pin voltage (V)	Pin description	Equivalent circuit
15 18	L. B NF	1.23	<ul style="list-style-type: none"> • Bass compensation circuit low-pass filter connection • The amount of bass boost depends on the capacitance used. 	
16 19	POWER OUT	1.23	<ul style="list-style-type: none"> • Power outputs 	
20	MUTE SW		<ul style="list-style-type: none"> • Muting on/off switch • 0 to 0.5 V: Muting off • 1.4 to 4.5 V: Muting on 	

- Specifications of any and all SANYO products described or contained herein stipulate the performance, characteristics, and functions of the described products in the independent state, and are not guarantees of the performance, characteristics, and functions of the described products as mounted in the customer's products or equipment. To verify symptoms and states that cannot be evaluated in an independent device, the customer should always evaluate and test devices mounted in the customer's products or equipment.
- SANYO Electric Co., Ltd. strives to supply high-quality high-reliability products. However, any and all semiconductor products fail with some probability. It is possible that these probabilistic failures could give rise to accidents or events that could endanger human lives, that could give rise to smoke or fire, or that could cause damage to other property. When designing equipment, adopt safety measures so that these kinds of accidents or events cannot occur. Such measures include but are not limited to protective circuits and error prevention circuits for safe design, redundant design, and structural design.
- In the event that any or all SANYO products (including technical data, services) described or contained herein are controlled under any of applicable local export control laws and regulations, such products must not be exported without obtaining the export license from the authorities concerned in accordance with the above law.
- No part of this publication may be reproduced or transmitted in any form or by any means, electronic or mechanical, including photocopying and recording, or any information storage or retrieval system, or otherwise, without the prior written permission of SANYO Electric Co., Ltd.
- Any and all information described or contained herein are subject to change without notice due to product/technology improvement, etc. When designing equipment, refer to the "Delivery Specification" for the SANYO product that you intend to use.
- Information (including circuit diagrams and circuit parameters) herein is for example only; it is not guaranteed for volume production. SANYO believes information herein is accurate and reliable, but no guarantees are made or implied regarding its use or any infringements of intellectual property rights or other rights of third parties.