



Monolithic Linear IC

LA5314

**Variable Divided Voltage Generator
for LCD Use**

Overview

The LA5314 is a variable divided voltage generator IC for multiple drive of LCD matrix.

Features

- Power supply for variable bias LCD matrix. (1/5 to 1/20 bias available by built-in resistances)
- Five operational amplifiers to deliver 5 voltage outputs
- Low current drain (1.6 mA typ)
- Miniflat package for miniturization

Package Dimensions

unit : mm

3222-HSOP28

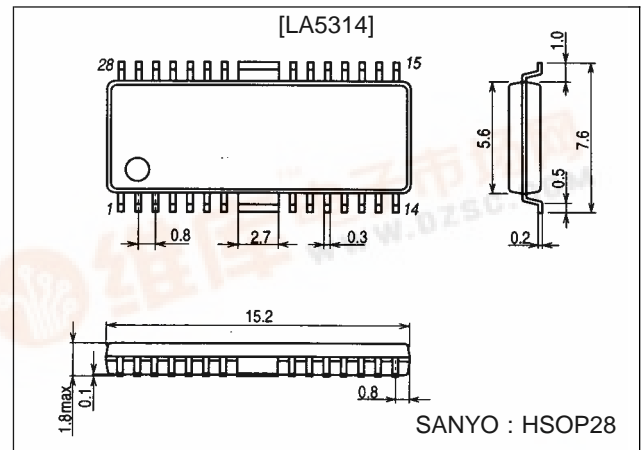

Specifications

Maximum Ratings at Ta = 25 °C

Parameter	Symbol	Conditions	Ratings	Unit
Maximum supply voltage	V _{CC} max	V _{CC} - V _{EE}	38	V
Maximum output current	I _{OUT} max	V ₀ to V ₄	*±25	mA
Allowable power dissipation	P _d max		600	mW
Operating temperature	T _{opr}		-20 to +75	°C
Storage temperature	T _{stg}		-30 to +150	°C

- Note: 1. Continuous operation (non breakdown) is guaranteed when operated at the maximum ratings shown above.
 2. *The maximum output current is a value specified under the conditions otherwise specified separately.

Operating Conditions at Ta = 25 °C

Parameter	Symbol	Conditions	Ratings	Unit
Supply voltage	V _{CC}	V _{CC} - V _{EE}	10 to 35	V
Output current	I _{OUT0, 1}	V ₀ , V ₁	-0.5 to +10	mA
	I _{OUT2, 3}	V ₂ , V ₃	-10 to +10	mA
	I _{OUT4}	V ₄	-15 to +0.5	mA

Note: 3. Set V_{CC} and V_{EE} so that |V₀-V₁| and |V₄| become 1V or greater.



LA5314

Operating Characteristics at $T_a = 25^\circ\text{C}$, $V_{CC} - V_{EE} = 20\text{ V}$, $V_{REF} = V_{CC}$, $R_X = 8R$

Parameter	Symbol	Conditions	min	typ	max	Unit
Current drain	I_{CC}, I_{EE}	$V_{CC}, V_{EE}: V_{CC} - V_{EE} = 20\text{ V}, R_X = 8R$		1.6	3	mA
Output voltage difference 1	Vd1	$(V_0 - V_1) - (V_1 - V_2)$	-30		+30	mV
Output voltage difference 2	Vd2	$(V_3 - V_4) - (V_4 - V_{EE})$	-30		+30	mV
Output voltage ratio 1	Rb1	$V_0/(V_0 - V_1)$	11.64	12.00	12.36	—
Output voltage ratio 2	Rb2	$V_0/(V_0 - V_2)$	5.82	6.00	6.18	—
Output voltage ratio 3	Rb3	V_0/V_3	5.82	6.00	6.18	—
Output voltage ratio 4	Rb4	V_0/V_4	11.64	12.00	12.36	—
Internal resistnace ratio 1	8R	$R_{X1} - R_{X2}^*$		8		—
Internal resistance ratio 2	12R	$R_{X1} - R_{X3}^*$		12		—
Internal resistance ratio 3	14R	$R_{X1} - R_{X4}^*$		14		—
Internal resistance ratio 4	15R	$R_{X1} - V_{IN3}^*$		15		—
Resistance	R	R value when 0.6 V is applied across $R_{X5} - R_{X6}$:		20		k Ω
Load regulation 1	ΔV_0	$V_0: -0.2\text{ mA} < I_{OUT0} < +10.0\text{ mA}$	-20		+20	mV
Load regulation 2	ΔV_1	$V_1: -0.2\text{ mA} < I_{OUT1} < +10.0\text{ mA}$	-20		+20	mV
Load regulation 3	ΔV_2	$V_2: -10.0\text{ mA} < I_{OUT2} < +10.0\text{ mA}$	-20		+20	mV
Load regulation 4	ΔV_3	$V_3: -10.0\text{ mA} < I_{OUT3} < +10.0\text{ mA}$	-20		+20	mV
Load regulation 5	ΔV_4	$V_4: -10.0\text{ mA} < I_{OUT4} < +0.2\text{ mA}$	-20		+20	mV

Note* : Referenced to R between R_{X4} and V_{IN3}

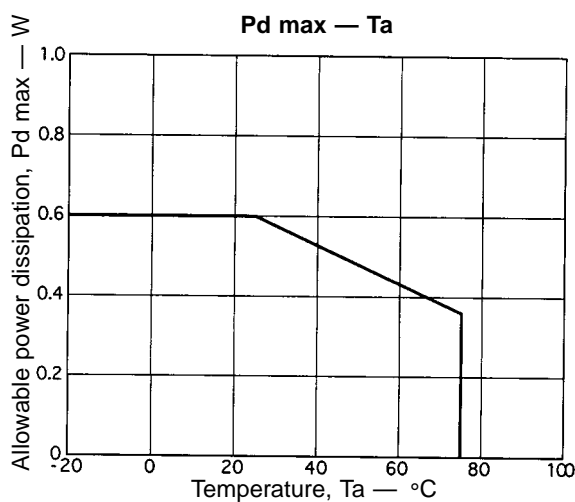

Pin Assignment

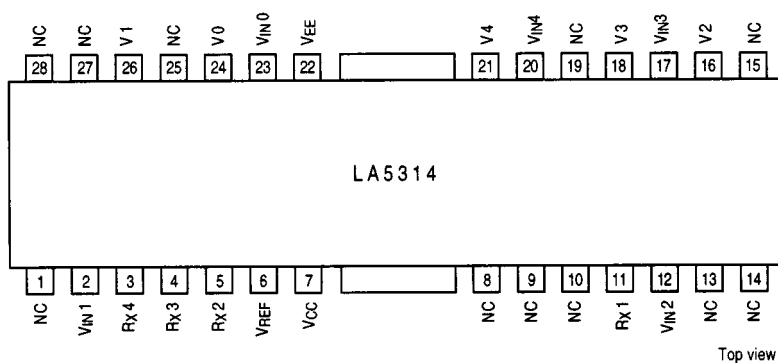

LA5314

Block Diagram

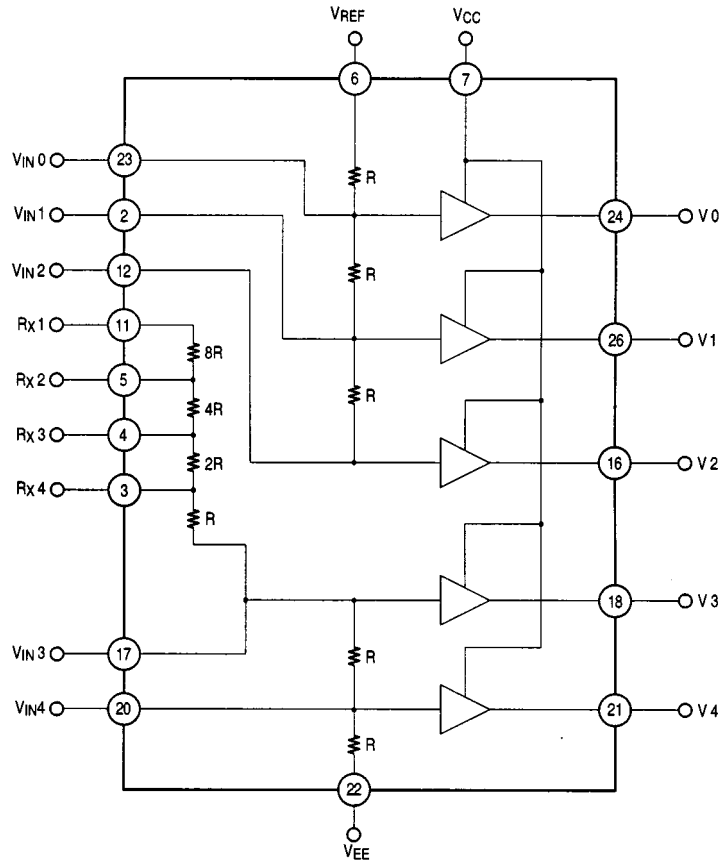

T00024

Note: Use the IC so that $V_{RX1} \cong V_{RX2} \cong V_{RX3} \cong V_{RX4}$ is obeyed.

LA5314

Maximum Output Current Load Test Conditions

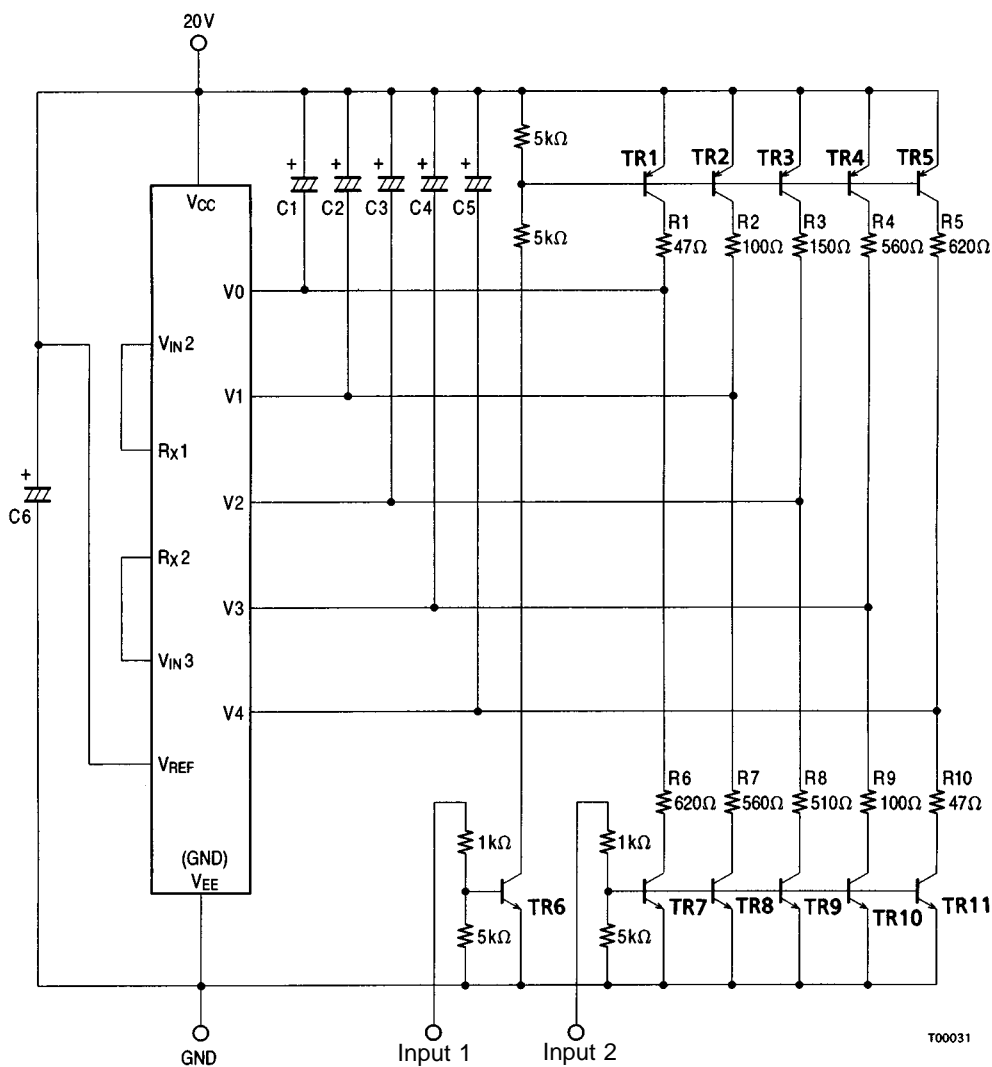

$V_{CC} - V_{EE} = 20 \text{ V}$, $R_X = 8R$
 $C1 = 5 \mu\text{F}$, $C2 = 10 \mu\text{F}$, $C3 = 10 \mu\text{F}$, $C4 = 5 \mu\text{F}$, $C5 = 10 \mu\text{F}$, $C6 = 33 \mu\text{F}$
 TR1 to TR5: 2SA984 E or F rank
 TR6 to TR11: 2SC2274 E or F rank

Unit (resistance: Ω , capacitance: F)

Output load resistances R1 to R10 are set in order that current of 30 mA max. are supplied to both source and sink sides when an on-level input is applied to the inputs 1 or 2.

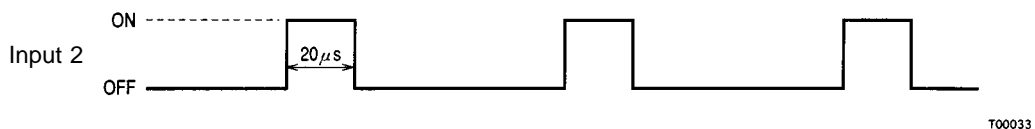
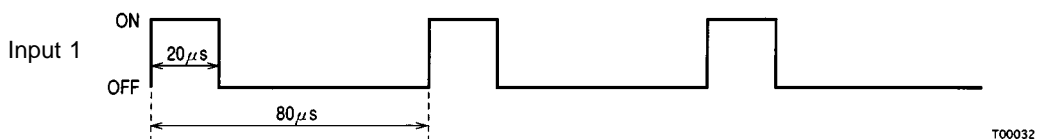

LA5314

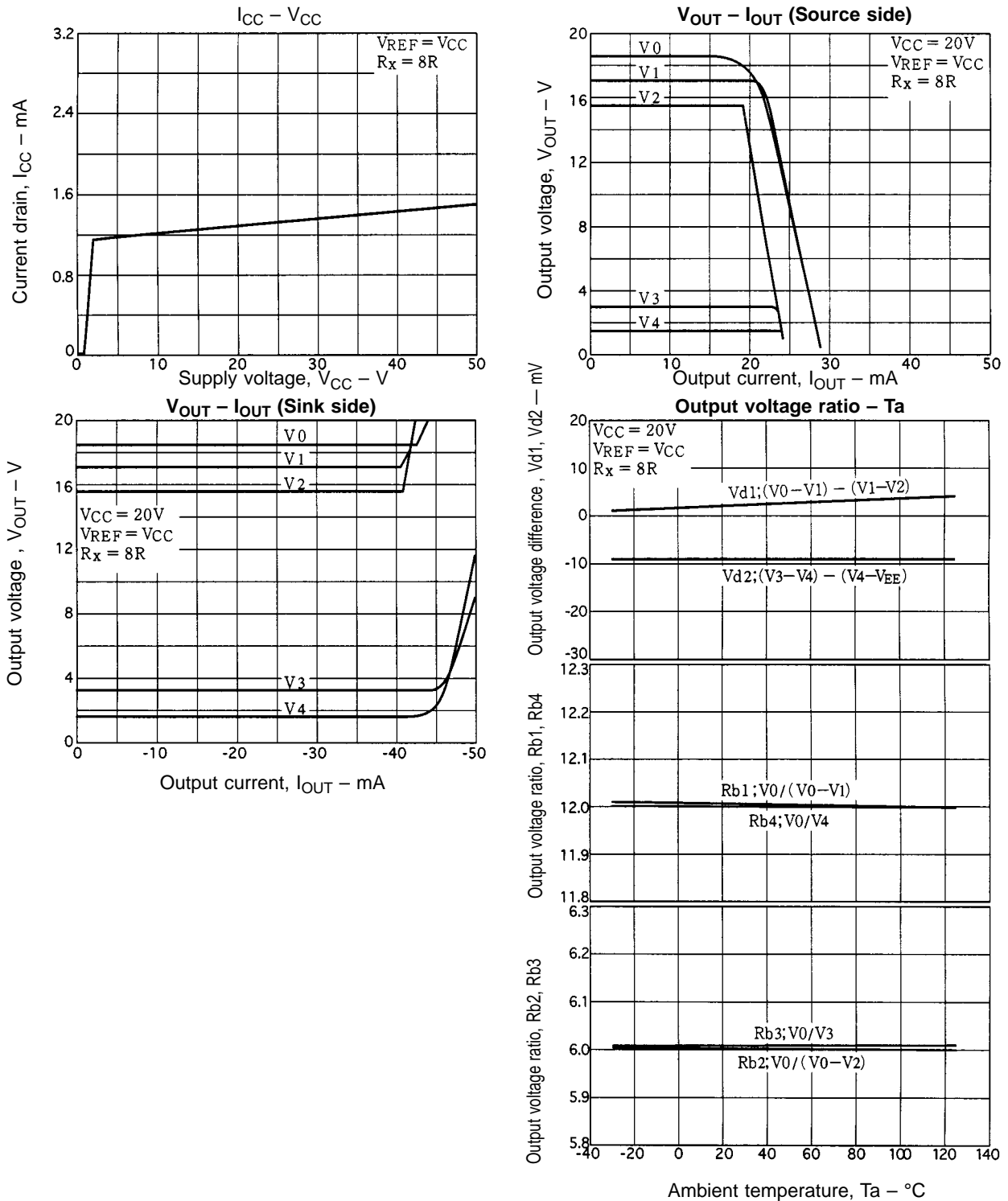

- No products described or contained herein are intended for use in surgical implants, life-support systems, aerospace equipment, nuclear power control systems, vehicles, disaster/crime-prevention equipment and the like, the failure of which may directly or indirectly cause injury, death or property loss.
- Anyone purchasing any products described or contained herein for an above-mentioned use shall:
 - ① Accept full responsibility and indemnify and defend SANYO ELECTRIC CO., LTD., its affiliates, subsidiaries and distributors and all their officers and employees, jointly and severally, against any and all claims and litigation and all damages, cost and expenses associated with such use:
 - ② Not impose any responsibility for any fault or negligence which may be cited in any such claim or litigation on SANYO ELECTRIC CO., LTD., its affiliates, subsidiaries and distributors or any of their officers and employees jointly or severally.
- Information (including circuit diagrams and circuit parameters) herein is for example only; it is not guaranteed for volume production. SANYO believes information herein is accurate and reliable, but no guarantees are made or implied regarding its use or any infringements of intellectual property rights or other rights of third parties.