

Monolithic Linear IC



LA5611

**Multifunctional Voltage Regulator
for TVs and VCRs**

Applications

- Audiovisual equipment, VCRs and TVs

Features

- Low saturation type of regulator (ON/OFF function built in)
- Control amplifier built in.
- Current limit and thermal limit circuits built in
- Reverse current prevention provided (V_{O4})

Package Dimensions

unit : mm

3107-SIP13H

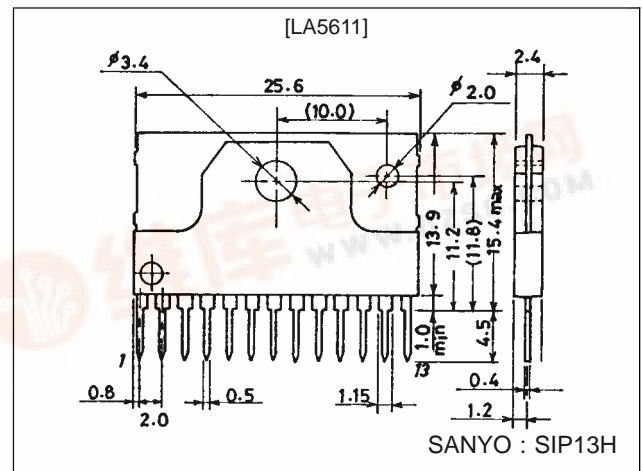

Specifications

Maximum Ratings at $T_a = 25^\circ\text{C}$

Parameter	Symbol	Conditions	Ratings	Unit
Maximum input voltage	V_{IN1} max		22	V
	V_{IN2} max	$V_{IN1} \geq V_{IN2}$	V_{IN1}	
Allowable power dissipation	P_d max	No heat sink	2	W
Thermal resistance between junction and case	θ_{j-c}		4.7	$^\circ\text{C/W}$
Operating temperature	T_{opr}		-20 to +80	$^\circ\text{C}$
Storage temperature	T_{stg}		-40 to +150	$^\circ\text{C}$

Operating Conditions at $T_a = 25^\circ\text{C}$

Parameter	Symbol	Conditions	Ratings	Unit
Input voltage	V_{IN1}		11.5 to 20	V
	V_{IN2}		6.2 to 20	V
Output current 1	I_{O1}	Within ASO of external T_r		mA
Output current 2	I_{O2}		10 to 480	mA
Output current 3	I_{O3}		10 to 240	mA
Output current 4	I_{O4}		5 to 48	mA



LA5611

Operating Characteristics at $T_a = 25\text{ }^\circ\text{C}$, See specified Test Circuit.

Parameter	Symbol	Conditions	min	typ	max	Unit
[No-load mode] $V_{EN} = \text{low}$, $V_{IN1} = 14\text{ V}$, $V_{IN2} = 6.6\text{ V}$, I_{O1} to $I_{O4} = 0\text{ mA}$						
Quiescent current	I_{IN1}			8	16	mA
	I_{IN2}			2	4	mA
[Regulator 1] $V_{EN} = \text{low}$, $V_{IN1} = 14\text{ V}$, $V_{IN2} = 6.6\text{ V}$, $I_{O1} = 500\text{ mA}$, with specified external transistor						
Output voltage 1	V_{O1}		8.5	9.0	9.5	V
Dropout voltage	V_{DROP1}			0.8	1.6	V
Line regulation	ΔV_{OLN1}	$12\text{ V} \leq V_{IN1} \leq 16\text{ V}$			140	mV
Load regulation	ΔV_{OLD1}	$0.1\text{ A} \leq I_{O1} \leq 1\text{ A}$			150	mV
Ripple rejection	Rrej1			50		dB
Output low-level voltage	V_{O1} OFF				0.2	V
Control output current	I_{CONT1}		10			mA
Output voltage/temperature coefficient	$\Delta V_{O1}/\Delta T_a$			± 1		mV/ $^\circ\text{C}$
[Regulator 2] $V_{EN} = \text{low}$, $V_{IN1} = 14\text{ V}$, $V_{IN2} = 6.6\text{ V}$, $I_{O2} = 400\text{ mA}$						
Output voltage 2	V_{O2}		4.80	5.05	5.30	V
Dropout voltage	V_{DROP2}			0.5	1.0	V
Line regulation	ΔV_{OLN2}	$6\text{ V} \leq V_{IN2} \leq 7.2\text{ V}$			20	mV
Load regulation	ΔV_{OLD2}	$0.1\text{ A} \leq I_{O2} \leq 0.4\text{ A}$			100	mV
Peak output current	I_{OP2}		480			mA
Output short-circuit current	I_{OSC2}			90	240	mA
Ripple rejection	Rrej2			50		dB
Output low-level voltage	V_{O2} OFF				0.2	V
Output voltage/temperature coefficient	$\Delta V_{O2}/\Delta T_a$			± 0.5		mV/ $^\circ\text{C}$
[Regulator 3] $V_{EN} = \text{high}$, $V_{IN1} = 14\text{ V}$, $V_{IN2} = 6.6\text{ V}$, $I_{O3} = 200\text{ mA}$						
Output voltage 3	V_{O3}		4.80	5.05	5.30	V
Dropout voltage	V_{DROP3}			0.5	1.0	V
Line regulation	ΔV_{OLN3}	$6\text{ V} \leq V_{IN2} \leq 7.2\text{ V}$			20	mV
Load regulation	ΔV_{OLD3}	$10\text{ mA} \leq I_{O3} \leq 200\text{ mA}$			100	mV
Peak output current	I_{OP3}		240			mA
Output short-circuit current	I_{OSC3}			40	120	mA
Ripple rejection	Rrej3			50		dB
Output voltage/temperature coefficient	$\Delta V_{O3}/\Delta T_a$			± 0.5		mV/ $^\circ\text{C}$
[Regulator 4] $V_{EN} = \text{high}$, $V_{IN1} = 14\text{ V}$, $V_{IN2} = 6.6\text{ V}$, $I_{O4} = 40\text{ mA}$						
Output voltage 4	V_{O4}		5.4	5.7	6.0	V
Dropout voltage	V_{DROP4}			3.8	5.0	V
Line regulation	ΔV_{OLN4}	$12\text{ V} \leq V_{IN1} \leq 16\text{ V}$			40	mV
Load regulation	ΔV_{OLD4}	$10\text{ mA} \leq I_{O4} \leq 40\text{ mA}$			65	mV
Peak output current	I_{OP4}		40			mA
Output short-circuit current	I_{OSC4}			70		mA
Ripple rejection	Rrej4			50		dB
Output voltage/temperature coefficient	$\Delta V_{O4}/\Delta T_a$			± 1		mV/ $^\circ\text{C}$
[Output on/off control] $V_{IN1} = 14\text{ V}$, $V_{IN2} = 6.6\text{ V}$						
Output on control voltage	V_{ENL}	V_{O1} , V_{O2} : on			1.0	V
Output off control voltage	V_{ENH}	V_{O1} , V_{O2} : off	3.0		V_{IN1}	V
[Control Amplifier] $V_{IN1} = 14\text{ V}$, $V_{IN2} = 6.6\text{ V}$						
Control output current	I_{CONT2}		10			mA
Resistance ratio	K_R	$K_R = R_4/R_3$, $V_{ref} = 1.28\text{ V typ}$		9.94		

LA5611

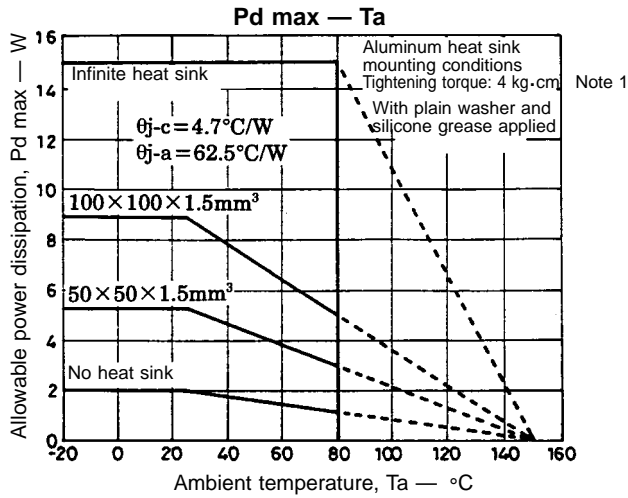

Note 1: The tightening torque referred to in the above figure is a condition specified for the heat dissipation characteristics and not a working condition to be met when mounting the heat sink.

Test Circuit

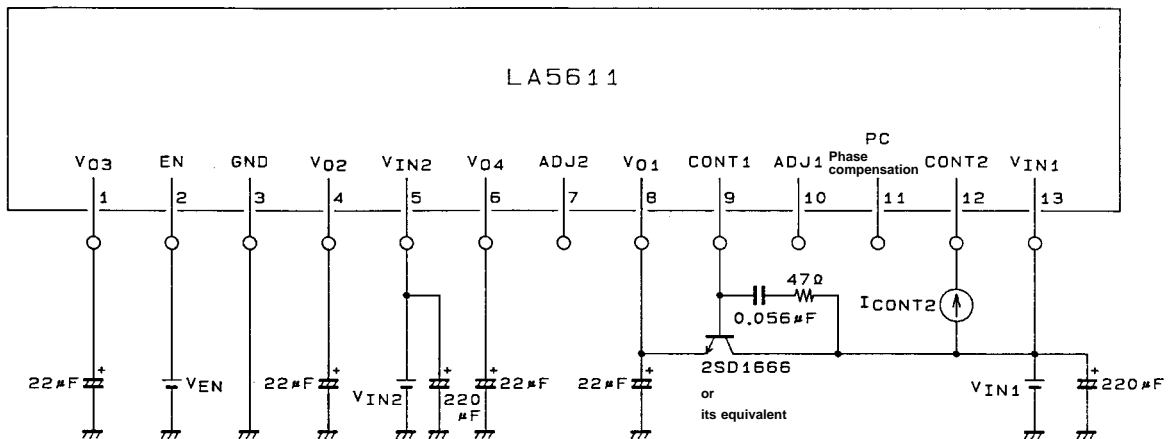

A04329

Pin Functions

No.	Symbol	Function
1	VO3	5.05 V/240 mA regulator, with current limit, thermal shutdown.
2	EN	Regulator 1 and regulator 2 on/off control. Low active.
3	GND	Substrate of the LA5611 (minimum potential).
4	VO2	5.05 V/480 mA regulator, with on/off, current limit, thermal shutdown.
5	VIN2	Low voltage input.
6	VO4	5.7 V/40 mA regulator with reverse current prevention.
7	ADJ2	VO1 adjustment pin. Resistance between pin 7 and ground → VO1 up. Resistance between pin 7 and pin 8 → VO1 down
8	VO1	Output voltage sensor of 9.0 V regulator
9	CONT1	Base control of external NPN transistor. ICONT1 = 10 mA, with on/off, thermal shutdown coupled with the internal thermal shutdown of this regulator.
10	ADJ1	VIN1 adjustment pin. Resistance between pin 10 and ground → VIN1 up. Resistance between pin 13 and pin 10 → VIN1 down
11	PC	Phase correction pin of switching regulator control amplifier.
12	CONT2	Drive output of switching regulator control amplifier.
13	VIN1	High voltage input.

LA5611

Function Table (○: built in, ×: not built in)

Function	Circuit block	V _{O1}	V _{O2}	V _{O3}	V _{O4}	Control amplifier
Input line		V _{IN1}	V _{IN2}	V _{IN2}	V _{IN1}	V _{IN1}
Current limit		×	○	○	○	×
Thermal limit		○	○	○	×	×
On/off control		○	○	×	×	×

Usage Notes

- Apply voltages to the voltage input pins on condition that $V_{IN1} \geq V_{IN2}$.
- Supply the voltages simultaneously to V_{IN1} and V_{IN2} . Do not use the LA5611 with voltage applied to only one of these pins.
- Since the control circuit of regulator 1 does not have current limit protection of such as an external NPN transistor, provide this protection in each application.

Logic Table

Conditions : when $V_{IN1} \geq V_{IN2}$ (at $V_{IN1} \geq 11.5$ V, $V_{IN2} \geq 6.2$ V)

EN	V _{O1} , V _{O2}
L or open	H
H	L

- “H” for EN denotes high level; “L” denotes low level.
- “H” for V_O denotes output ON voltage; “L” denotes output OFF voltage.

Thermal Design Notes

- In the LA5611, the junction temperature (T_j) at which thermal shutdown is activated is approximately equal to 130°C.
- Consequently, the operating temperature range of REG1, REG2 and REG3 with the thermal shutdown function is restricted by the thermal shutdown characteristics (typical value) shown in the figure below.
- The thermal shutdown characteristics vary $\pm 20^\circ\text{C}$ or so. Since thermal shutdown is liable to occur with inadequate heat dissipation, sufficient consideration must be given to the heat dissipation design.

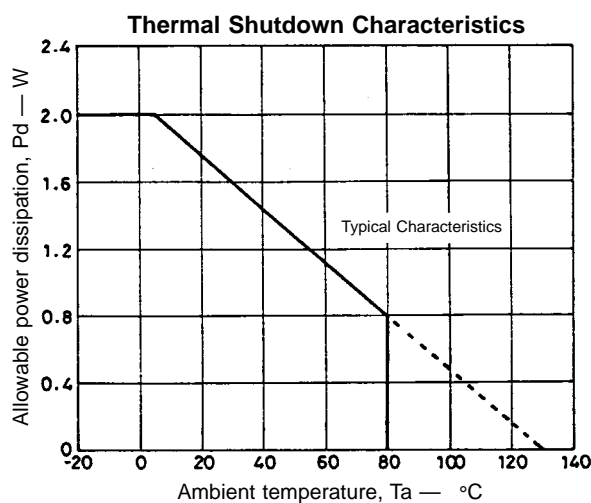

LA5611

Equivalent Circuit Block Diagram and Sample Application Circuit

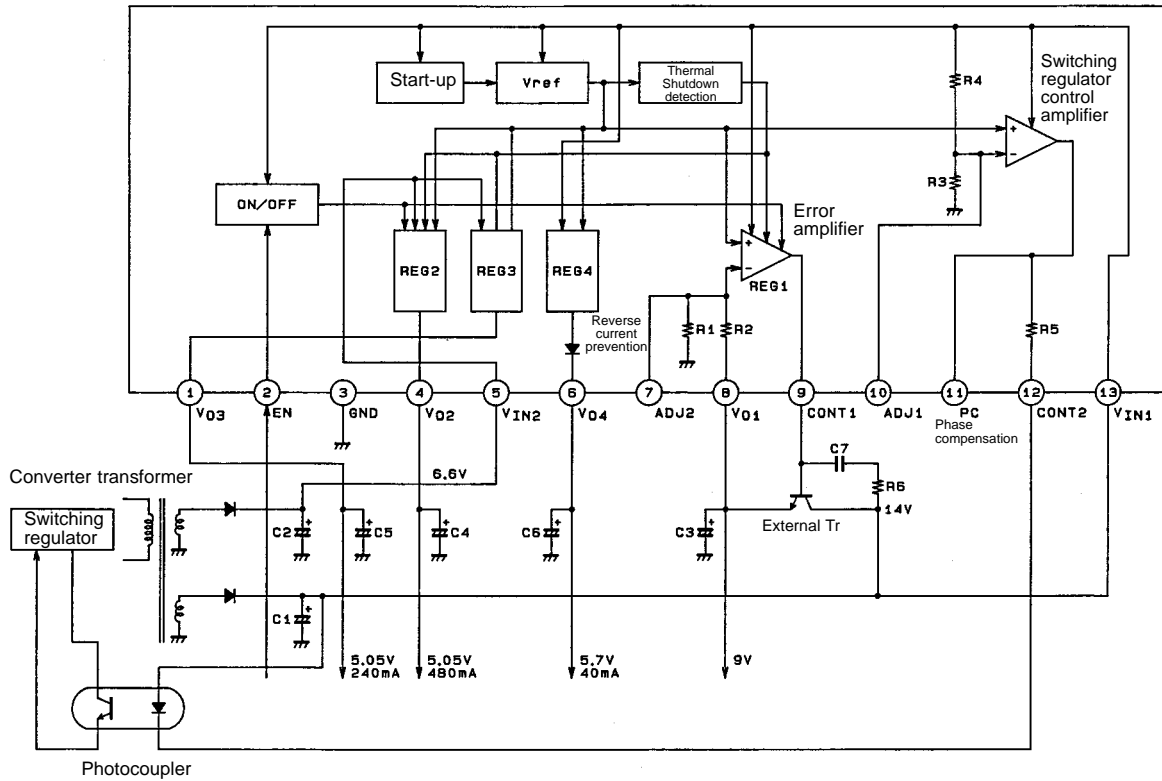

A0432B

Application Notes

- (1) Depending on the type, load current and connection position (distance from the LA5611) of the external NPN transistor, the capacitor C7 and resistance R6 is necessary for preventing oscillation.
- (2) C1 to C6 are bypass capacitors for preventing oscillation: as such, they must be positioned as close to the LA5611 as possible in order to stabilize operation.

- No products described or contained herein are intended for use in surgical implants, life-support systems, aerospace equipment, nuclear power control systems, vehicles, disaster/crime-prevention equipment and the like, the failure of which may directly or indirectly cause injury, death or property loss.
- Anyone purchasing any products described or contained herein for an above-mentioned use shall:
 - ① Accept full responsibility and indemnify and defend SANYO ELECTRIC CO., LTD., its affiliates, subsidiaries and distributors and all their officers and employees, jointly and severally, against any and all claims and litigation and all damages, cost and expenses associated with such use:
 - ② Not impose any responsibility for any fault or negligence which may be cited in any such claim or litigation on SANYO ELECTRIC CO., LTD., its affiliates, subsidiaries and distributors or any of their officers and employees jointly or severally.
- Information (including circuit diagrams and circuit parameters) herein is for example only; it is not guaranteed for volume production. SANYO believes information herein is accurate and reliable, but no guarantees are made or implied regarding its use or any infringements of intellectual property rights or other rights of third parties.