

Ordering number : EN5719

Monolithic Linear IC



LA5623M

Combination System Reset IC

Overview

The LA5623M is a combination reset IC that provides two reset functions. The first, reset 1, detects the input voltage and applies a reset to the CPU system and other logic systems. The second, reset 2, detects the power supply voltage when the power is turned on or off, and applies a reset to the CPU system and other logic systems. This latter function allows the reset time to be adjusted from two external pins.

Features

- Reset circuit (output 1) that detects the input voltage and provides a delay time of 200 μ s.
- System reset circuit (output 2) that provides a switchable delay time of 25, 50, 100, or 200 ms.
- Low operating limit voltage
- Both reset 1 and reset 2 have hysteresis characteristics.

Specifications

Maximum Ratings at $T_a = 25^\circ\text{C}$

Parameter	Symbol	Conditions	Ratings	Unit
Supply voltage	V_{CC}		-0.3 to +12	V
Output 1 sink current	I_{SINK1}		8	mA
Output 2 sink current	I_{SINK2}		8	mA
Output voltage	V_O		-0.3 to +10	V
Manual input voltage	V_{RES}		-0.3 to +10	V
Input voltage range	V_{IN1}		-0.3 to +10	V
Ct0, Ct1 voltage	V_{ct}		0 to +10	V
Allowable power dissipation	$P_d \text{ max}$		250	mW
Operating temperature	T_{opr}		-20 to +75	$^\circ\text{C}$
Storage temperature	T_{stg}		-40 to +125	$^\circ\text{C}$

Operating Conditions at $T_a = 25^\circ\text{C}$

Parameter	Symbol	Conditions	Ratings	Unit
Recommended supply voltage	V_{CC}		2 to 10	V
Input voltage range	V_{IN}	For pulse widths of up to 20 ns	-2 to $V_{CC} + 1$	V
Input high-level voltage	V_{RESH}	For pulse widths of up to 20 ns	$V_{CC} + 1$	V
Input low-level voltage	V_{RESL}	For pulse widths of up to 20 ns	-2	V

Package Dimensions

unit: mm

3032B-MFP8

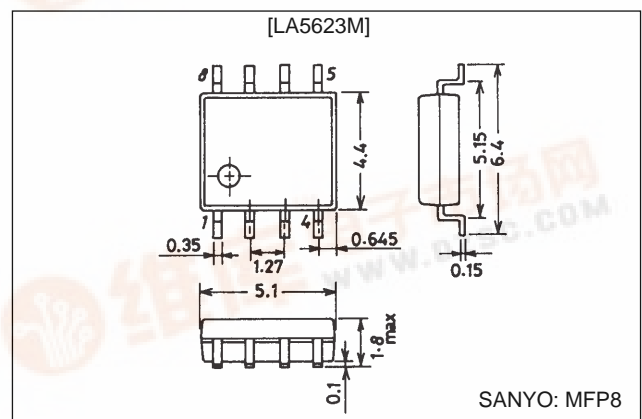

LA5623M

Operating Characteristics at Ta = 25°C, VCC = 5 V

Parameter	Symbol	Conditions	Ratings			Unit
			min	typ	max	
[Reset Circuit 1, 2 Common]						
Current drain when off	I _{CC1}		–	1.4	2.0	mA
Current drain when on	I _{CC2}	When reset 1 and 2 are both on	–	2	3	mA
Detection voltage temperature coefficient	VS/ΔT		–	0.01		%/°C
Output high-level voltage	V _{OH}	I _{OH} = –40 μA	0.9 V _{CC}	–	–	V
Low-level signal propagation delay	t _{PHL}	C _L = 100 pF	–	10	–	μs
Operating limit voltage *1	V _{OPL}	R _L = 2.2 kΩ, V(sat) ≤ 0.4 V	–	0.67	0.80	V
		R _L = 100 kΩ, V(sat) ≤ 0.4 V	–	0.55	0.70	V
Internal pull-up resistance	R		5	10	15	kΩ
[Reset Circuit 1]						
Sense voltage 1	VS1		1.20	1.25	1.30	V
Hysteresis voltage 1	ΔVS1		9	15	23	mV
High-level signal propagation delay 1	t _{PLH1}	C _L = 100 pF	80	200	500	μs
Output low voltage 1	V _{OL1}	V _{IN} < 1.2 V, I _{OL} = 5 mA	–	0.2	0.4	V
Input voltage range	V _{IN1}		–0.3	–	+10	V
Input current	I _{IN1}	V _{IN} = 1.25 V	–	100	500	nA
[Reset Circuit 2]						
Sense voltage 2	VS2		4.0	4.2	4.4	V
Hysteresis voltage 2	ΔVS2		30	50	100	mV
High-level signal propagation delay 2	t _{PLH2}	Ct0 = "L", Ct1 = "H" : CL = 100pF	15	25	35	ms
		Ct0 = "H", Ct1 = "L" : CL = 100pF	30	50	70	ms
		Ct0 = "H", Ct1 = "H" : CL = 100pF	60	100	140	ms
		Ct0 = "L", Ct1 = "L" : CL = 100pF	120	200	280	ms
Output low-level voltage 2	V _{OL2}	V _{CC} < 4.0 V, I _{OL} = 5 mA	–	0.2	0.4	V
Input high-level voltage *2	V _{RESH2}		2	–	10	V
Input high-level current *2	I _{RESH2}	V _{RES} = 2 V	–	–	80	μA
Input low-level voltage *2	V _{RESL2}		–0.3	–	+0.8	V

Notes: 1. The minimum supply voltage such that a low-level output can be maintained.

2. Manual reset.

A high level applied to the manual reset pin sets the output 2 pin low, and a low level sets the output 2 pin high.

Pin Assignment

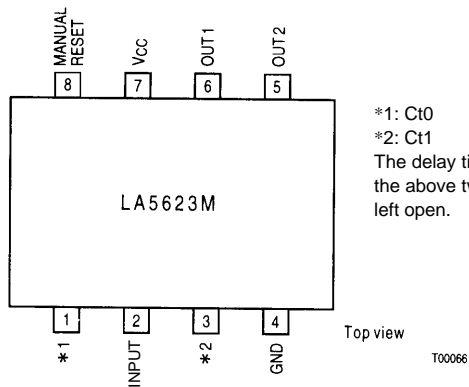

LA5623M

Block Diagram

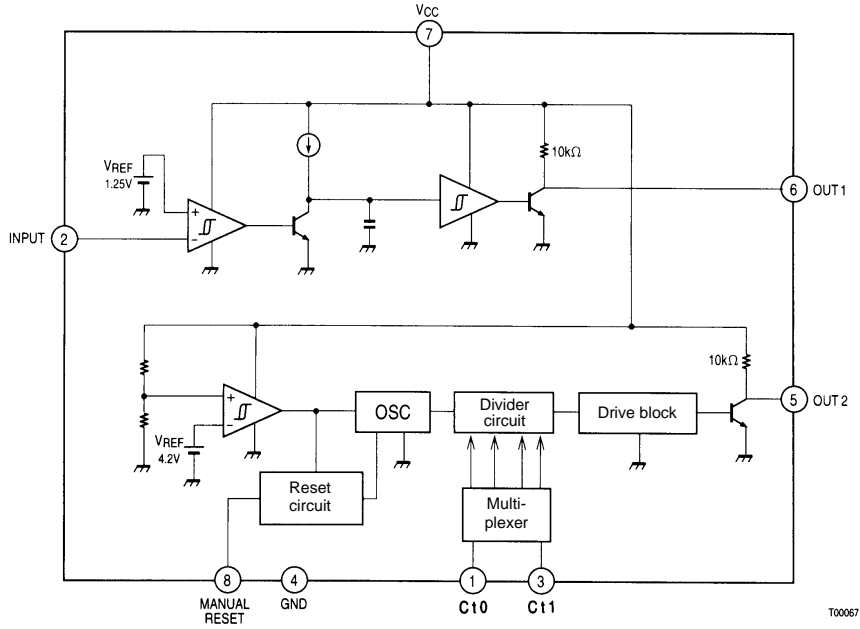

Operating Waveforms

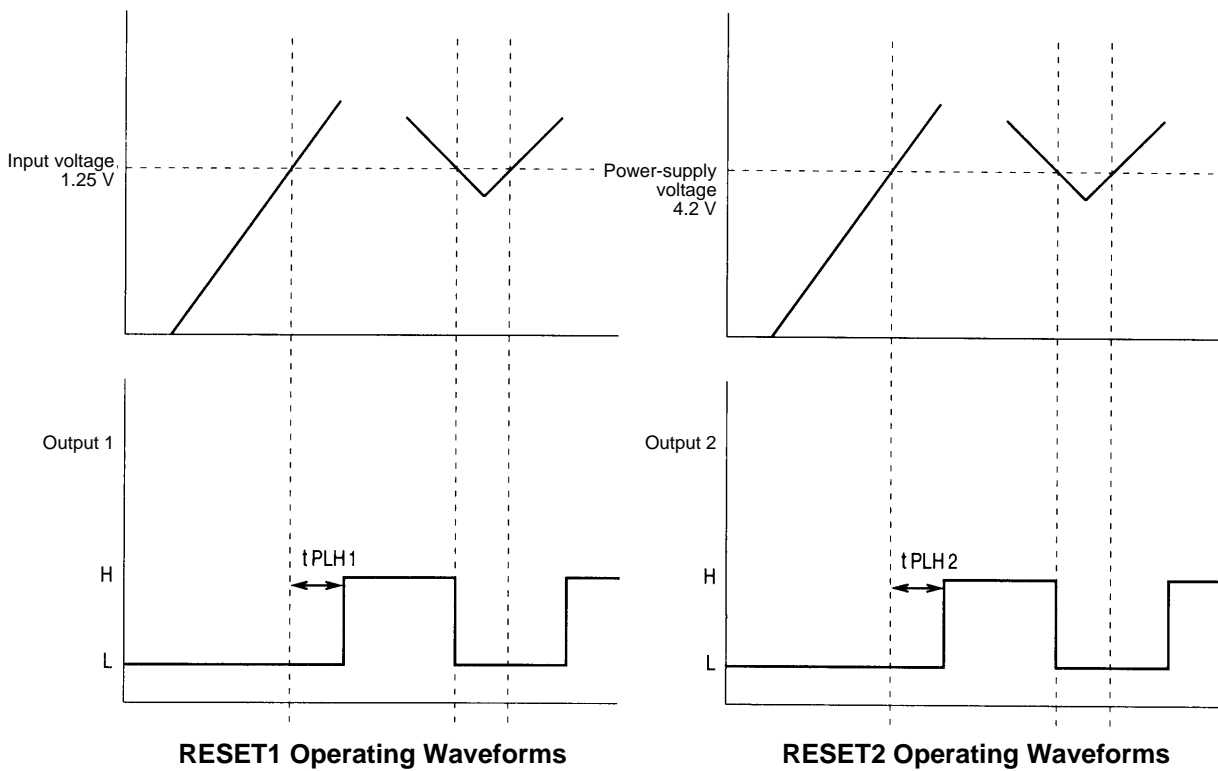

LA5623M

RESET2 Truth Table

Ct0	Ct1	RESET2 delay time
L	H	25 ms
H	L	50 ms
H or OPEN	H or OPEN	100 ms
L	L	200 ms

MANUAL RESET Truth Table

MANUAL RESET	OUT2
H	L
L	H

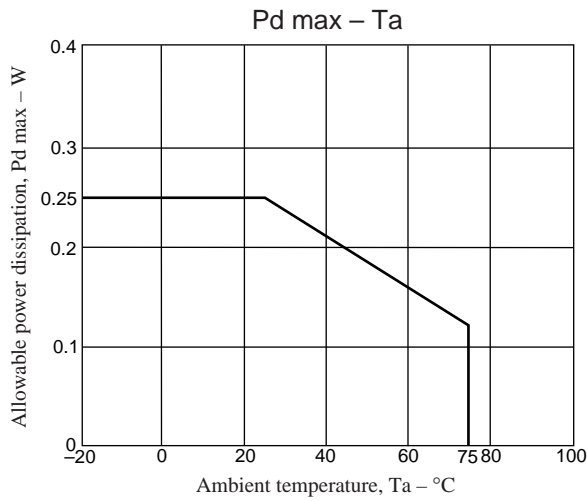

- No products described or contained herein are intended for use in surgical implants, life-support systems, aerospace equipment, nuclear power control systems, vehicles, disaster/crime-prevention equipment and the like, the failure of which may directly or indirectly cause injury, death or property loss.
- Anyone purchasing any products described or contained herein for an above-mentioned use shall:
 - ① Accept full responsibility and indemnify and defend SANYO ELECTRIC CO., LTD., its affiliates, subsidiaries and distributors and all their officers and employees, jointly and severally, against any and all claims and litigation and all damages, cost and expenses associated with such use:
 - ② Not impose any responsibility for any fault or negligence which may be cited in any such claim or litigation on SANYO ELECTRIC CO., LTD., its affiliates, subsidiaries and distributors or any of their officers and employees jointly or severally.
- Information (including circuit diagrams and circuit parameters) herein is for example only; it is not guaranteed for volume production. SANYO believes information herein is accurate and reliable, but no guarantees are made or implied regarding its use or any infringements of intellectual property rights or other rights of third parties.

This catalog provides information as of June, 1997. Specifications and information herein are subject to change without notice.