



The LA6530, 6531 are 2-channel BTL-use drivers designed for compact disc pickup actuation.

Functions and Features

- High output current (I_O max = 0.7A)
- Wide operating voltage range (4 to 15V)
- Low input bias current
- LA6530 Output of amps 1 to 4 at muting-ON mode : OFF
- LA6531 Output of amps 1 to 4 and buffer amp at muting-ON mode : OFF

Maximum Ratings at $T_a = 25^\circ\text{C}$

			unit
Maximum Supply Voltage	V_{CC} max	16	V
Allowable Power Dissipation	P_d max	1.9	W
Differential Input Voltage	V_{ID} Amp 2, amp 3	15	V
Common-Mode Input Voltage	V_{ICM} Amp 2, amp 3	15	V
Maximum Input Voltage	V_{INB} max Buffer amp	15	V
Maximum Flow-in Current at Muting Pin	I_M max	1.0	mA
Maximum Output Current	I_O max	0.7	A
Operating Temperature	T_{opr}	-20 to +75	$^\circ\text{C}$
Storage Temperature	T_{stg}	-55 to +150	$^\circ\text{C}$

Operating Conditions at $T_a = 25^\circ\text{C}$

			unit
Maximum Supply Voltage	V_{CC} max	5	V
Load Resistance	R_L	8	Ω

Operating Characteristics at $T_a = 25^\circ\text{C}, V_{CC} = 5.0\text{V}$

			min	typ	max	unit
No-Loaded Current Dissipation 1	I_{CC1}	Mute OFF, pins 8,9,16 GND	5	10	20	mA
No-Loaded Current Dissipation 2	I_{CC2}	Mute OFF, pins 8,9,16 GND	3	7	15	mA
No-Loaded Current Dissipation 3	I_{CC3}	Mute OFF, pins 8,9,16 1/2 V_{CC}	10	20	30	mA
No-Loaded Current Dissipation 4	I_{CC4}	Mute OFF, pins 8,9,16 1/2 V_{CC}	4	8	16	mA

Continued on next page.

Package Dimensions 3054A-D16FNIC (unit : mm)

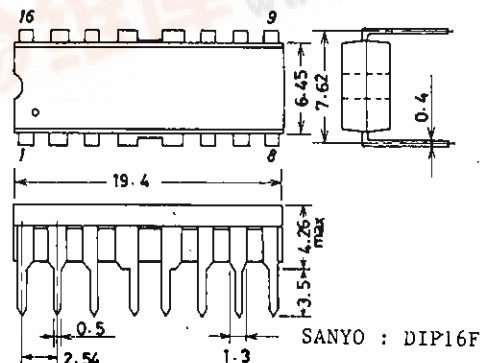

LA6530, 6531

Continued from preceding page.

			min	typ	max	unit
Output Offset Voltage 1	V_{OF1}	Out 1 - Out 2	-50		50	mV
Output Offset Voltage 2	V_{OF2}	Out 4 - Out 3	-50		50	mV
Buffer Input-Output Voltage Difference	V_{BIO}	Buffer amp	-30		30	mV
Buffer Input Voltage Range	V_{BICM}	Buffer amp	1.5	$V_{CC} - 1.5$		V
Common-Mode Input Voltage Range	V_{ICM}	Amp 2, amp 3	1.0	$V_{CC} - 1.5$		V
Input Bias Current	I_B			50	300	nA
Output Voltage	V_O	$R_L = 8.0\Omega$	2.8	3.3		V
Bridge Output Voltage Difference	V_{OD}	Pins 3-6, 11-14 8Ω load	1.8	2.2		V
Closed-Circuit Voltage Gain	V_G		30	38		dB
Muting Pin ON-State Voltage	V_M			0.7		V
Muting Pin Flow-in Current	I_M			3		μA

Note) With thermal shutdown function

※ : The LA6530 is so designed that the outputs at OUT1 to OUT4 are turned OFF and the output at VBOUT is not turned OFF at the muting-ON mode.

※ : The LA6531 is so designed that the outputs at OUT1 to OUT4 and the output at VBOUT are turned OFF.

※ : Be careful in handling the LA6530, 6531, because dielectric breakdown is liable to occur.

Equivalent Circuit Block Diagram

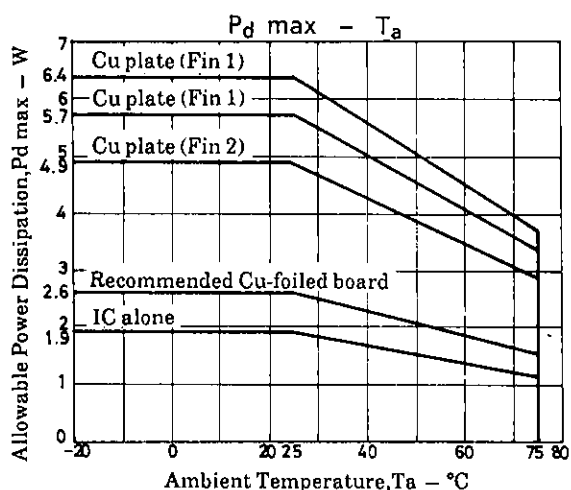
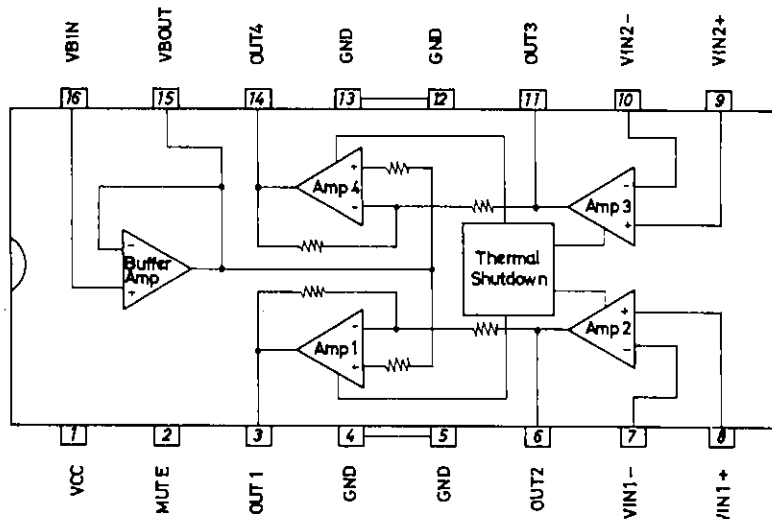

Sample Printed Circuit Pattern

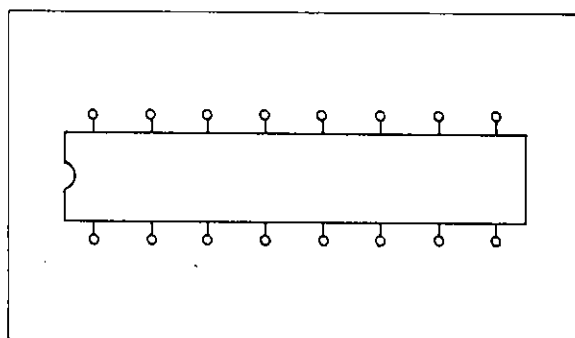

Cu-foiled area $80 \times 60 \text{mm}^2$

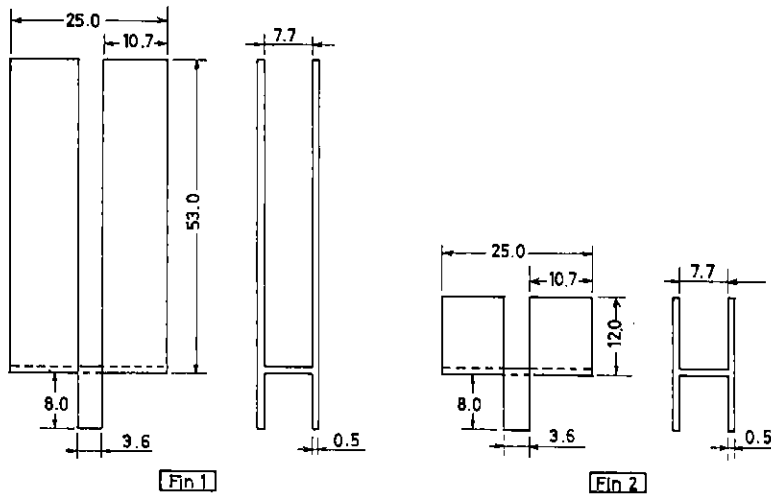

- No products described or contained herein are intended for use in surgical implants, life-support systems, aerospace equipment, nuclear power control systems, vehicles, disaster/crime-prevention equipment and the like, the failure of which may directly or indirectly cause injury, death or property loss.
- Anyone purchasing any products described or contained herein for an above-mentioned use shall:
 - ① Accept full responsibility and indemnify and defend SANYO ELECTRIC CO., LTD., its affiliates, subsidiaries and distributors and all their officers and employees, jointly and severally, against any and all claims and litigation and all damages, cost and expenses associated with such use:
 - ② Not impose any responsibility for any fault or negligence which may be cited in any such claim or litigation on SANYO ELECTRIC CO., LTD., its affiliates, subsidiaries and distributors or any of their officers and employees jointly or severally.
- Information (including circuit diagrams and circuit parameters) herein is for example only; it is not guaranteed for volume production. SANYO believes information herein is accurate and reliable, but no guarantees are made or implied regarding its use or any infringements of intellectual property rights or other rights of third parties.