



The LA6532M is a 4-channel BTL-use driver designed for compact disc pickup actuation.

Functions and Features

- BTL-use 4-channel power amp
- I_O max 700mA × 2400mA × 2 (with voltage limiter)
- With muting function

Maximum Ratings at $T_a = 25^\circ\text{C}$

		unit
Maximum Supply Voltage	V_{CC} max	9 V
Allowable Power Dissipation	P_d max	0.9 W
Differential Input Voltage	V_{ID}	8 V
Common-Mode Input Voltage	V_{ICM}	8 V
Maximum Input Voltage	V_{INB} max Buffer amp	8 V
Muting Pin Voltage	V_{Mute}	8 V
Operating Temperature	T_{opr}	-20 to +75 °C
Storage Temperature	T_{stg}	-55 to +150 °C

Operating Conditions at $T_a = 25^\circ\text{C}$

		unit
Maximum Supply Voltage	V_{CC}	5 V
Load Resistance	R_L Pins 3-4,12-13,18-19,27-28	8 Ω

Operating Characteristics at $T_a = 25^\circ\text{C}, V_{CC} = 5.0\text{V}$

			min	typ	max	unit
No-Loaded Current Dissipation 1	I_{CC1} Note 1		25	40	60	mA
No-Loaded Current Dissipation 2	I_{CC2} Note 2		5	9	20	mA
No-Loaded Current Dissipation 3	I_{CC3} Note 3		25	40	60	mA
No-Loaded Current Dissipation 4	I_{CC4} Note 4		5	9	20	mA
Output Offset Voltage 1	V_{OF1} Note 5 Amp 1-2,7-8		-50		50	mV
Output Offset Voltage 2	V_{OF2} Note 5 Amp 3-4,5-6		-30		30	mV

Continued on next page.

Package Dimensions 3073A-M30IC
(unit : mm)

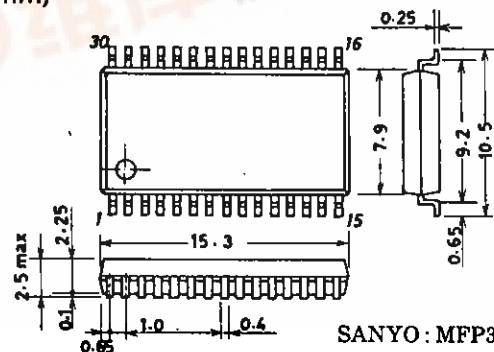

SANYO : MFP30S

LA6532M

Continued from preceding page.

			min	typ	max	unit
Buffer 1 Input-Output Voltage Difference	V_{BIO1}	Buffer amp 1	-30		30	mV
Buffer 2 Input-Output Voltage Difference	V_{BIO2}	Buffer amp 2	0.5	0.6	0.8	V
Amp 2 Input-Output Voltage Difference	V_{IO2}	Amp 2	0.5	0.6	0.8	V
Amp 7 Input-Output Voltage Difference	V_{IO7}	Amp 7	0.5	0.6	0.8	V
Input Bias Current	I_B	Note 6		100	500	nA
Buffer Input Voltage Range	V_{BICM}	Buffer amp	1.5	$V_{CC}-1.5$		V
Common-Mode Input Voltage Range	V_{ICM}		1.0	$V_{CC}-1.5$		V
Output Source Voltage	V_{O1}	$R_L=8.0\Omega$ 700mA amp (Note 7)	3.4	3.6		V
Output Sink Voltage	V_{O2}	$R_L=8.0\Omega$ 700mA amp (Note 8)		1.0	1.4	V
Output Source Voltage	V_{O3}	$R_L=8.0\Omega$ 400mA amp (Note 7)	2.8	3.4		V
Output Sink Voltage	V_{O4}	$R_L=8.0\Omega$ 400mA amp (Note 8)		1.6	2.2	V
Closed-Circuit Voltage Gain	V_G			6.0		dB
Output Limiting Voltage	V_{OL}	Amp 3, amp 6		5.0		V
Muting Pin OFF-State Voltage	V_{Mute}			2.2		V
Muting Pin OFF-State Current	I_{Mute}			80		A

Note 1 Muting OFF. Buffer 22k Ω across V_{IN-} and V_O . V_{IN+} pin grounded

Note 2 Muting ON. Buffer 22k Ω across V_{IN-} and V_O . V_{IN+} pin grounded

Note 3 Muting OFF. Buffer 22k Ω across V_{IN-} and V_O . V_{IN+} pin connected to $1/2V_{CC}$

Note 4 Muting ON. Buffer 22k Ω across V_{IN-} and V_O . V_{IN+} pin connected to $1/2V_{CC}$

Note 5 For bridge amp, represents the difference between outputs.

Note 6 All V_{IN} connected to $1/2V_{CC}$. 100k Ω connected to the input. Measure the voltage difference. V_{IN} and V_O connected through 100k Ω . Measure the voltage difference between pins.

Note 7 Voltage (source) relative to GND when 8 Ω load is connected across outputs of bridge amp

Note 8 Voltage (sink) relative to GND when 8 Ω load is connected across outputs of bridge amp

※ : Be carefull in handling the LA6532M, because dielectric breakdown is liable to occur.

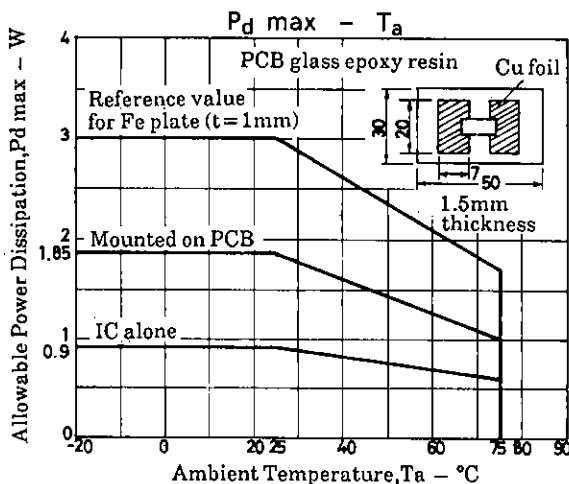

LA6532M

Equivalent Circuit Block Diagram

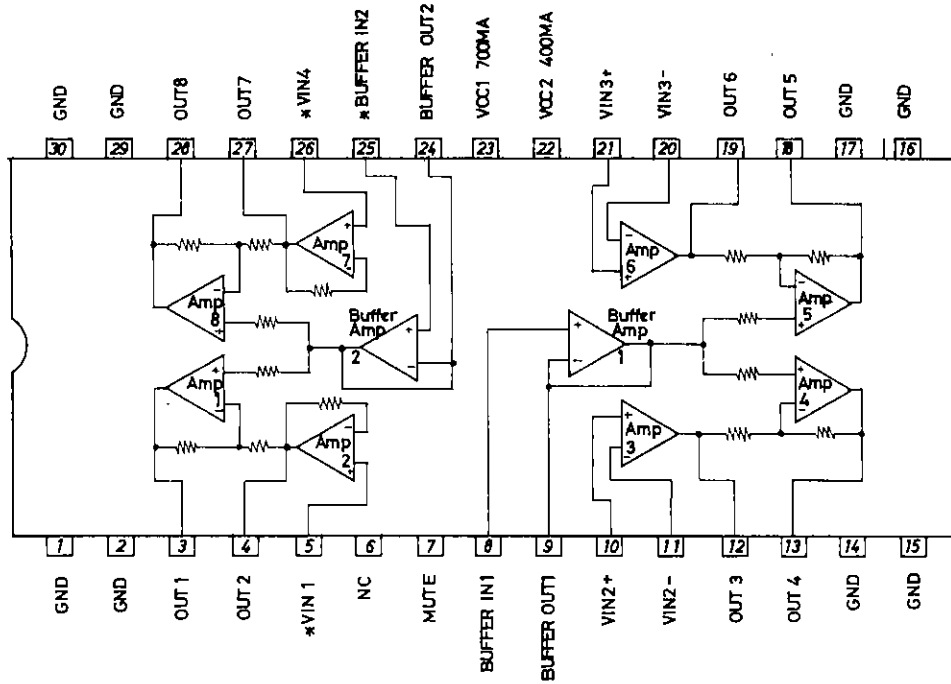

- No products described or contained herein are intended for use in surgical implants, life-support systems, aerospace equipment, nuclear power control systems, vehicles, disaster/crime-prevention equipment and the like, the failure of which may directly or indirectly cause injury, death or property loss.
- Anyone purchasing any products described or contained herein for an above-mentioned use shall:
 - ① Accept full responsibility and indemnify and defend SANYO ELECTRIC CO., LTD., its affiliates, subsidiaries and distributors and all their officers and employees, jointly and severally, against any and all claims and litigation and all damages, cost and expenses associated with such use.
 - ② Not impose any responsibility for any fault or negligence which may be cited in any such claim or litigation on SANYO ELECTRIC CO., LTD., its affiliates, subsidiaries and distributors or any of their officers and employees jointly or severally.
- Information (including circuit diagrams and circuit parameters) herein is for example only; it is not guaranteed for volume production. SANYO believes information herein is accurate and reliable, but no guarantees are made or implied regarding its use or any infringements of intellectual property rights or other rights of third parties.