

Ordering number : ENN6296

Monolithic Linear IC



LA6545M

Four-Channel Bridge (BTL) Driver for CD-ROM

Overview

The LA6545M is a 4-channel bridge (BTL) driver developed for use in CD-ROM systems.

Functions

- Bridge connected (BTL) four-channel power amplifier
- V_{CE} (residual voltage) minimized (channels 1 and 2) by using two power supplies.
- I_{Omax} : 1.0 A
- Muting circuit provided (output on/off control)

(MUTE pin: low for output off, high for output on.
MUTE1: controls channels 1, 2, and 3, MUTE2: controls channel 4.)

- Thermal protection (shutdown) circuit
- Separated output stage power supply (VS1: channels 1 and 2, VS2: channels 3 and 4)

Package Dimensions

unit: mm

3129-MFP36SLF

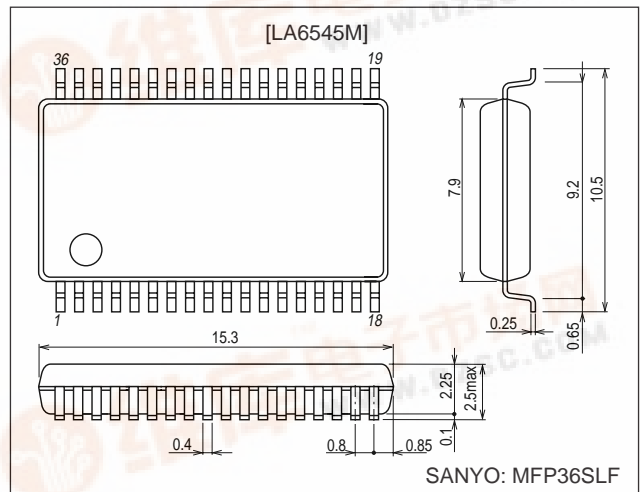
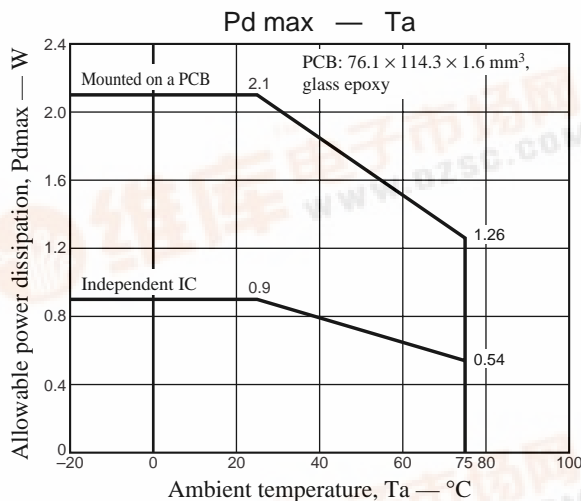

Specifications

Maximum Ratings at Ta = 25°C

Parameter	Symbol	Conditions	Ratings	Unit
Maximum supply voltage 1	$V_{CC\ max}$	$V_{CC} \geq V_{S1, 2}$	14	V
Maximum supply voltage 2	$V_S\ max$	$V_{S1, 2}, V_{CC} \geq V_{S1, 2}$	14	V
Input voltage	$V_{IN\ max}$	Each of the input pins V_{IN1} to V_{IN4}	13	V
MUTE pin voltage	$V_{MUTE\ max}$		13	V
Allowable power dissipation	Pd max	Independent IC	0.9	W
		Mounted on the specified PCB (76.1 × 114.3 × 1.6 mm ³ , glass epoxy)	2.1	W
Operating temperature	T_{opr}		-20 to +75	°C
Storage temperature	T_{stg}		-55 to +150	°C

■ Any and all SANYO products described or contained herein do not have specifications that can handle applications that require extremely high levels of reliability, such as life-support systems, aircraft's control systems, or other applications whose failure can be reasonably expected to result in serious physical and/or material damage. Consult with your SANYO representative nearest you before using any SANYO products described or contained herein in such applications.

■ SANYO assumes no responsibility for equipment failures that result from using products at values that exceed, even momentarily, rated values (such as maximum ratings, operating condition ranges, or other parameters) listed in products specifications of any and all SANYO products described or contained herein.



LA6545M

Recommended Operating Conditions at $T_a = 25^\circ\text{C}$

Parameter	Symbol	Conditions	Ratings	Unit
Operating supply voltage	V_{CC}	$V_{CC} \geq V_{S1, 2}$	4 to 13	V
	$V_{S1, 2}$	V_{S1} and V_{S2} are the output stage power supply. $V_{CC} \geq V_{S1}$ and V_{S2}	4 to 13	V

Electrical Characteristics at $T_a = 25^\circ\text{C}$, $V_{CC} = V_{S2} = 12\text{ V}$, $V_{S1} = 5\text{ V}$, $V_{REF} = 1.65\text{ V}$

Parameter	Symbol	Conditions	Ratings			Unit
			min	typ	max	
V_{CC} no load current drain 1	I_{CC-ON}	Output on (MUTE1 and MUTE2: high), V_{CC}		10	25	mA
V_{CC} no load current drain 2	I_{CC-OFF}	Output off (MUTE1 and MUTE2: low), V_{CC}			4	mA
V_{S1} no load current drain 1	I_{S1-ON}	Output on (MUTE1 and MUTE2: high), V_{S1}		20	30	mA
V_{S1} no load current drain 2	I_{S2-OFF}	Output off (MUTE1 and MUTE2: low), V_{S1}			4	mA
V_{S2} no load current drain 1	I_{S2-ON}	Output on (MUTE1 and MUTE2: high), V_{S2}		20	30	mA
V_{S2} no load current drain 2	I_{S2-OFF}	Output off (MUTE1 and MUTE2: low), V_{S2}			4	mA
Output offset voltage	V_{OF1} to 4	Potential difference between the + and – outputs for each channel	-50		+50	mV
Input voltage range 1	V_{IN1}	Input voltage range for each channel	0		V_{S1}	V
Output voltage 1	V_{O1}	$I_O = 700\text{ mA}$, the difference between the outputs for channels 1 and 2	4	4.5		V
Output voltage 2	V_{O2}	$I_O = 700\text{ mA}$, the difference between the outputs for channels 3 and 4	10.5	11		V
Closed circuit voltage gain	V_{G1}	The BTL amplifier voltage gain for channels 1 and 2	5	7	9	dB
	V_{G2}	The BTL amplifier voltage gain for channels 3 and 4	12	14	16	dB
Slew rate	SR	This value is doubled when measured across the outputs. *1		0.5		V/ μs
Muting on voltage	V_{MUTE}	MUTE1 and MUTE2. The voltage at which the output turns on. *2		1.5	2	V

Notes 1. Design guarantee value.

2. The MUTE1, and MUTE2 pins turn the output on when high and off when low. When the output is off, the outputs will be in the high-impedance state.

The figure below shows the relationship between the channels and the MUTE pins and between the channels and the power supplies.

System Figure

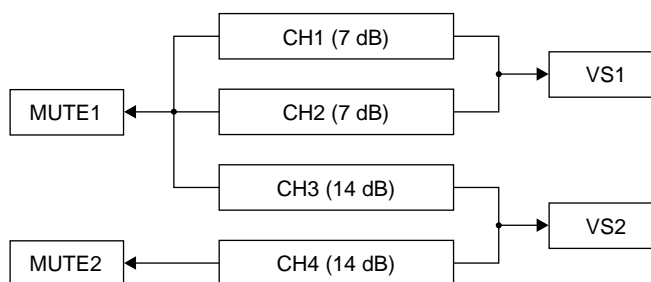

A12688

LA6545M

Block Diagram and Pin Assignment

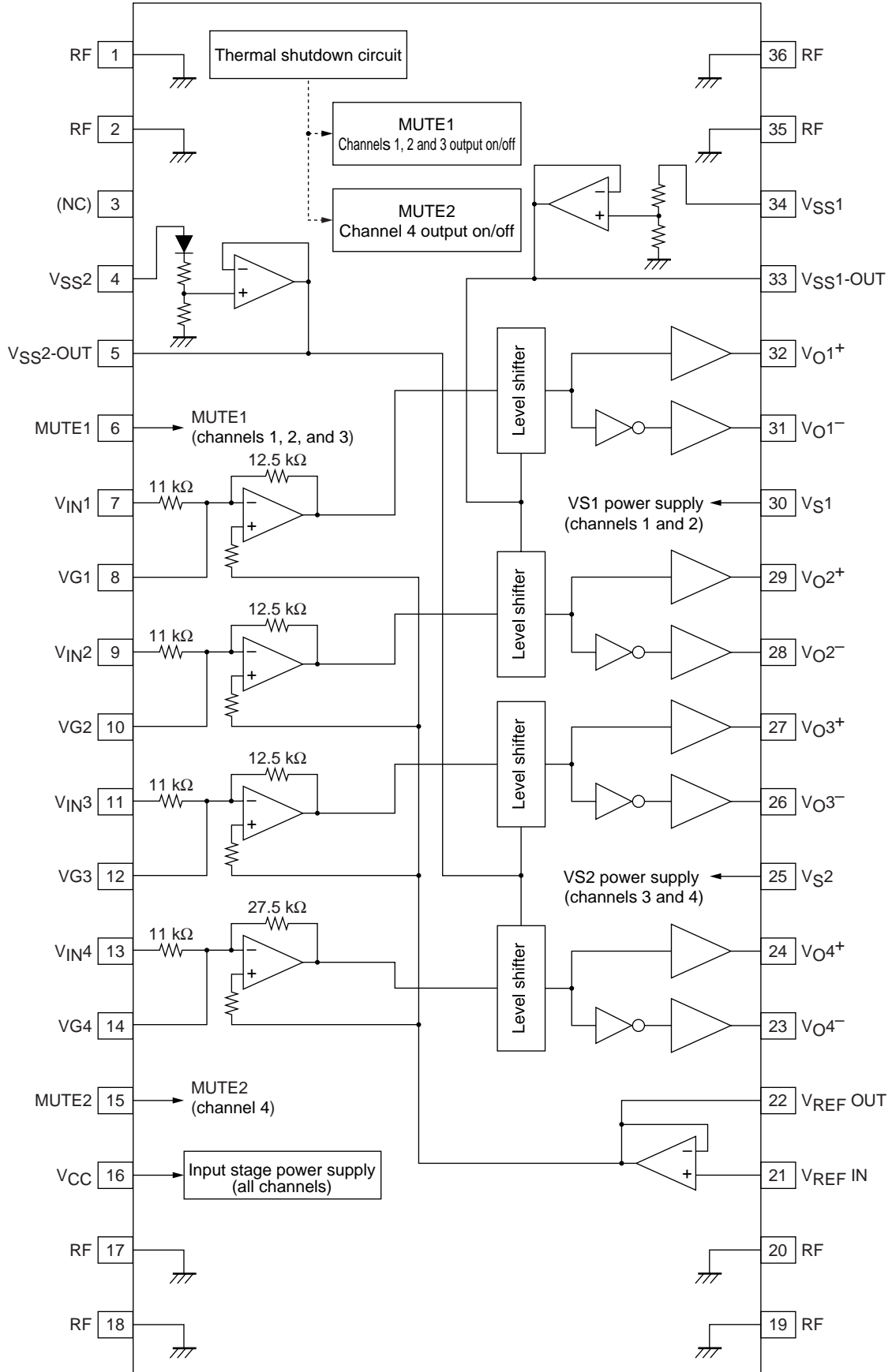

LA6545M

Pin Functions

Pin No.	Pin	Function
1	RF	Substrate (lowest potential)
2	RF	Substrate (lowest potential)
3	(NC)	Unused.
4	V _{SS2}	Connect to V _{S2} .
5	V _{SS2} -OUT	Output stage reference voltage output ((V _{S2} -V _{BE})/2, typical)
6	MUTE1	Channels 1, 2, and 3 output on/off control
7	V _{IN1}	Channel 1 input
8	VG1	Channel 1 input (gain adjustment)
9	V _{IN2}	Channel 2 input
10	VG2	Channel 2 input (gain adjustment)
11	V _{IN3}	Channel 3 input
12	VG3	Channel 3 input (gain adjustment)
13	V _{IN4}	Channel 4 input
14	VG4	Channel 4 input (adjustment)
15	MUTE2	Channel 4 on/off control
16	V _{CC}	Power supply
17	RF	Substrate (lowest potential)
18	RF	Substrate (lowest potential)
19	RF	Substrate (lowest potential)
20	RF	Substrate (lowest potential)
21	V _{REF} IN	Reference voltage input (V _{REF1} buffer amplifier input)
22	V _{REF} OUT	Reference voltage output (V _{REF1} buffer amplifier output)
23	V _{O4-}	Channel 4 inverted output
24	V _{O4+}	Channel 4 noninverted output
25	V _{S2}	Channels 3 and 4 output stage power supply
26	V _{O3-}	Channel 3 inverted output
27	V _{O3+}	Channel 3 noninverted output
28	V _{O2-}	Channel 2 inverted output
29	V _{O2+}	Channel 2 noninverted output
30	V _{S1}	Channels 1 and 2 output stage power supply
31	V _{O1-}	Channel 1 inverted output
32	V _{O1+}	Channel 1 noninverted output
33	V _{SS1} -OUT	Output stage reference voltage (Outputs V _{SS} /2: typical) (V _{REF2} buffer amplifier output)
34	V _{SS1}	Connect to V _{S1} . (V _{SS1} - OUT is generated by a resistor divider.)
35	RF	Substrate (lowest potential)
36	RF	Substrate (lowest potential)

LA6545M

Sample Application Circuit

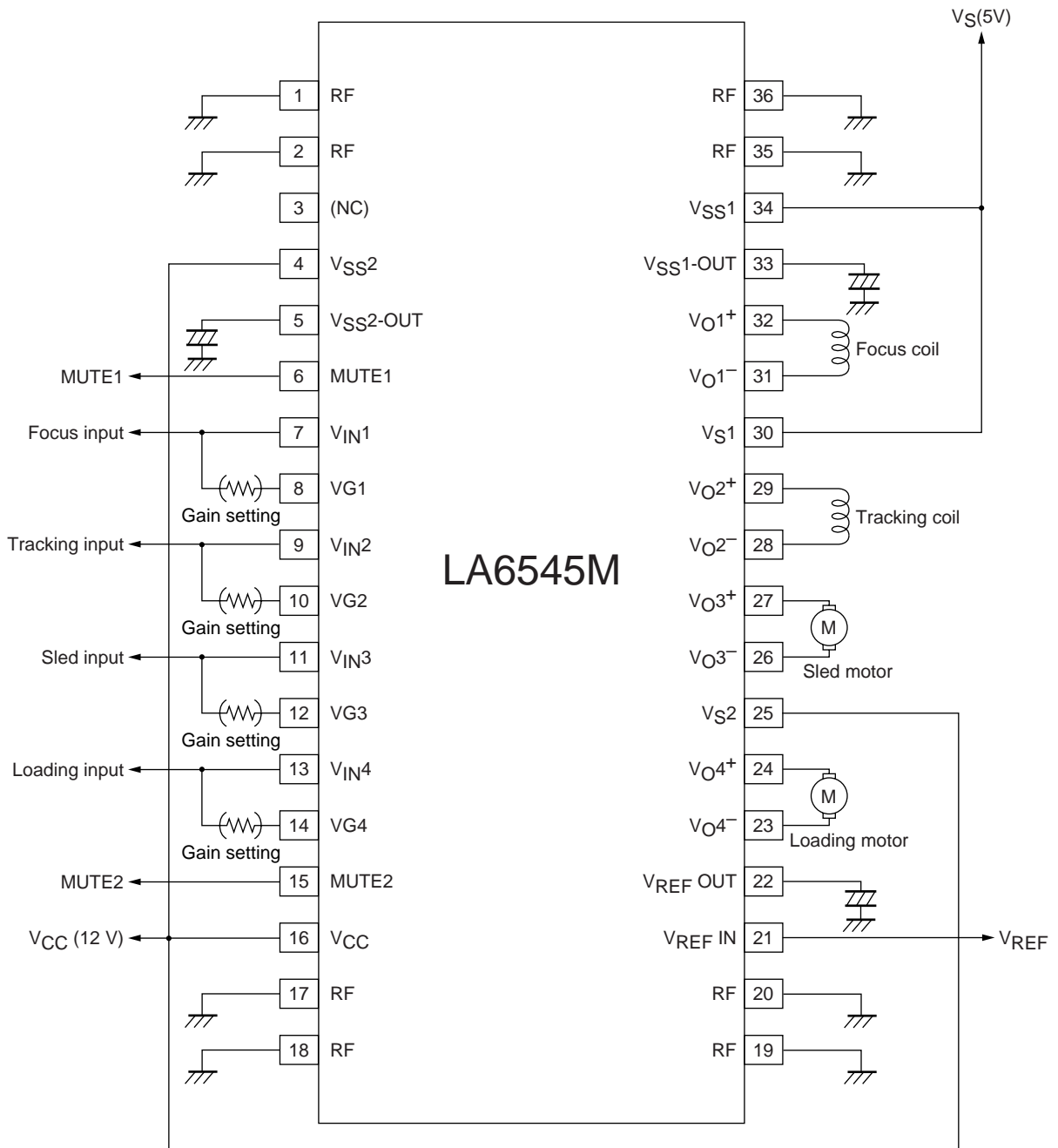

LA6545M

Pin Description

Pin No.	Pin	Symbol	Function	Equivalent circuit
7 8 9 10 11 12 13 14	V_{IN}^* VG^* (Input)	V_{IN1} $VG1$ V_{IN2} $VG2$ V_{IN3} $VG3$ V_{IN4} $VG4$	Inputs for each channel	
32 31 29 28 27 26 24 23	V_O^* (Output)	V_{O1+} V_{O1-} V_{O2+} V_{O2-} V_{O3+} V_{O3-} V_{O4+} V_{O4-}	Outputs for each channel	
6 15	MUTE	MUTE1 MUTE2	Output on/off control	

LA6545M

Gain Setting (Functions of the Input and Gain Adjustment Pins)

The figures present overviews of the V_{IN} and V_G pin circuits. (These are the same as the block diagrams.)

1. Consider resistors ($11\text{ k}\Omega$, typical) to be inserted between the V_{IN} and V_G pins. This should be seen as being the same as the operational amplifier noninverting input (V_{IN}^+).
2. If the V_G pins are not used, and only the V_{IN} pins are used, the BTL gain (across the V_{O^+} and V_{O^-} outputs) will be 7 dB for channels 1 and 2 (amplifier units: 1 dB + BTL: 6 dB) and 14 dB for channels 3 and 4 (amplifier units: 8 dB + BTL: 6 dB).

If the V_{IN} pins are not used and $11\text{ k}\Omega$ external resistors are attached to the V_G pins, input to the opposite ends of those resistors will result in equivalent circuit operation. However, the V_{IN} pins should be used and the gain set to minimize the I/O gain temperature characteristics.

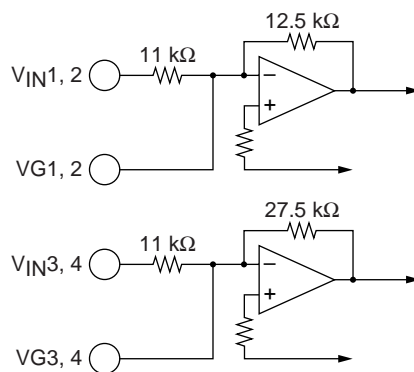

A12694

Offset Voltage

This IC includes built-in level shifting circuits. For input to which V_{REF} is applied as a reference, the output is referenced to the voltage $V_{SS1}/2$ (V) for channels 1 and 2, and the output is referenced to the voltage $(V_{SS2} - V_{BE(0.7)})/2$ (V) for channels 3 and 4.

- Specifications of any and all SANYO products described or contained herein stipulate the performance, characteristics, and functions of the described products in the independent state, and are not guarantees of the performance, characteristics, and functions of the described products as mounted in the customer's products or equipment. To verify symptoms and states that cannot be evaluated in an independent device, the customer should always evaluate and test devices mounted in the customer's products or equipment.
- SANYO Electric Co., Ltd. strives to supply high-quality high-reliability products. However, any and all semiconductor products fail with some probability. It is possible that these probabilistic failures could give rise to accidents or events that could endanger human lives, that could give rise to smoke or fire, or that could cause damage to other property. When designing equipment, adopt safety measures so that these kinds of accidents or events cannot occur. Such measures include but are not limited to protective circuits and error prevention circuits for safe design, redundant design, and structural design.
- In the event that any or all SANYO products (including technical data, services) described or contained herein are controlled under any of applicable local export control laws and regulations, such products must not be exported without obtaining the export license from the authorities concerned in accordance with the above law.
- No part of this publication may be reproduced or transmitted in any form or by any means, electronic or mechanical, including photocopying and recording, or any information storage or retrieval system, or otherwise, without the prior written permission of SANYO Electric Co., Ltd.
- Any and all information described or contained herein are subject to change without notice due to product/technology improvement, etc. When designing equipment, refer to the "Delivery Specification" for the SANYO product that you intend to use.
- Information (including circuit diagrams and circuit parameters) herein is for example only; it is not guaranteed for volume production. SANYO believes information herein is accurate and reliable, but no guarantees are made or implied regarding its use or any infringements of intellectual property rights or other rights of third parties.