

Ordering number : N5288A

Monolithic Linear IC



LA7337

**SECAM-Format VCR
Chroma Signal-Processing Circuit**

Overview

The LA7337 is an IC that implements SECAM-format VCR signal processing in a single chip. It incorporates band-pass filters and a SECAM discrimination circuit on chip and features automatic adjustment of the bell filter for a reduced number of external components and adjustment-free circuit operation.

Features

- All required filters, except for the bell filter, incorporated on chip.
- Automatic adjustment of the bell filter f_0 parameter
- Built-in SECAM discrimination circuit

Functions

- 4.3-MHz and 1.1-MHz band-pass filters, limiter, AGC (in playback mode)
- Divide-by-four circuit, 4× frequency multiplier circuit, 2.2-MHz band-pass filter
- Bell filter f_0 automatic adjustment circuit, SECAM discrimination circuit
- Sync gate

Specifications

Absolute Maximum Ratings at $T_a = 25^\circ\text{C}$

Parameter	Symbol	Conditions	Ratings	Unit
Maximum supply voltage	$V_{CC \text{ max}}$		7	V
Allowable power dissipation	$P_d \text{ max}$	$T_a \leq 70^\circ\text{C}$	600	mW
Operating temperature	T_{opr}		-15 to +70	$^\circ\text{C}$
Storage temperature	T_{stg}		-40 to +150	$^\circ\text{C}$

Operating Conditions at $T_a = 25^\circ\text{C}$

Parameter	Symbol	Conditions	Ratings	Unit
Recommended supply voltage	V_{CC}		5	V
Operating supply voltage range	$V_{CC \text{ op}}$		4.8 to 5.5	V

Package Dimensions

unit: mm

3063-DIP28S

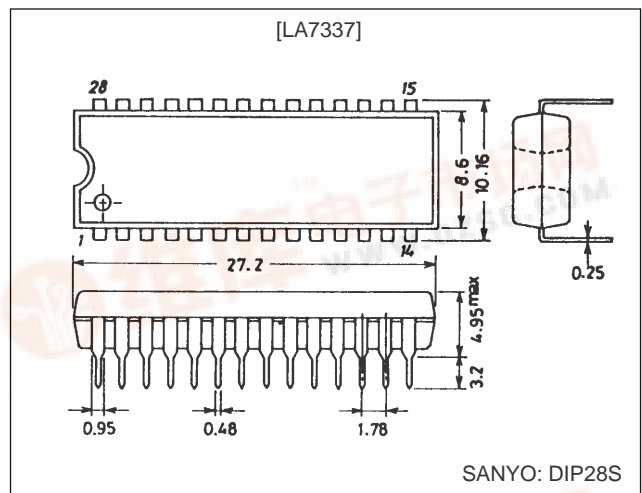

LA7337

Operating Characteristics at Ta = 25°C, VCC = 5 V

Parameter	Symbol	Conditions	Ratings			Unit
			min	typ	max	
Record mode current drain	I _{CCR}	V5 = V6 = 0 V, V16 = 0 V, S27 = composite sync., S15 = color bar signal	50	70	90	mA
4.3-MHz band-pass filter characteristics (1)	V _{F4C}	V6 = 5 V, V16 = 0 V, S27 = composite sync. S15 = sine wave (200 mVp-p, f = 4.286 MHz)	145	180	215	mVp-p
4.3-MHz band-pass filter characteristics (2)	G _{F4L1}	As above, except S15 = sine wave (200 mVp-p, f = 1.1 MHz), taking V _{F4C} as the reference (0 dB)		-30	-20	dB
4.3-MHz band-pass filter characteristics (3)	G _{F4L2}	As above, except S15 = sine wave (200 mVp-p, f = 2.2 MHz), taking V _{F4C} as the reference (0 dB)		-10	-5	dB
4.3-MHz band-pass filter characteristics (4)	G _{F4H}	As above, except S15 = sine wave (200 mVp-p, f = 7.5 MHz), taking V _{F4C} as the reference (0 dB)		-30	-20	dB
Record mode bell filter center frequency (1)	F _{BLR1}	V5 = V6 = 0 V, V16 = 0 V, SW21B = on, S15 = sine wave (200 mVp-p, f = 4 to 5 MHz), S27 = composite sync.	4.243	4.286	4.329	MHz
Record mode bell filter center frequency (2)	F _{BLR2}	As above, except V5 = 4 V.	4.493	4.536	4.579	MHz
Record mode bell filter characteristics (1)	V _{BLRC}	V5 = V6 = 0 V, V16 = 0 V, SW21B = on, S15 = sine wave (200 mVp-p, f = F _{BLR1}), S27 = composite sync.	200	250	300	mVp-p
Record mode bell filter characteristics (2)	G _{BLRL}	As above, except S15 = sine wave (200 mVp-p, f = 3.8 MHz), taking V _{BLRC} as the reference (0 dB)	-14	-11	-8	dB
Record mode bell filter characteristics (3)	G _{BLRH}	As above, except S15 = sine wave (200 mVp-p, f = 4.8 MHz), taking V _{BLRC} as the reference (0 dB)	-14	-11	-8	dB
Record mode killer operating level	G _{KLR}	V5 = V6 = 0 V, S15 = a SECAM color bar signal (variable level), V16 = 0 V, SW21B = on, V23 = 3.4 V, V24 = 3.7 V, S27 = composite sync.	-28	-23	-18	dB
Record equalization center frequency (1)	F _{EQR1}	SW1 = on, V1 = 5 V, V5 = V6 = 0 V, V16 = 0 V, S21 = sine wave (200 mVp-p, f = 4 to 5 MHz), SW21A = SW21B = on, S27 = composite sync.	1.0608	1.0715	1.0822	MHz
Record equalization center frequency (2)	F _{EQR2}	As above, except V6 = 4 V	1.0788	1.0895	1.1002	MHz
Record equalization characteristics (1)	V _{EQRC}	SW1 = on, V1 = 5 V, V5 = V6 = 0 V, V16 = 0 V, S21 = sine wave (200 mVp-p, f = F _{EQR1} × 4), SW21A = SW21B = on, S27 = composite sync.	65	85	105	mVp-p
Record equalization characteristics (2)	G _{EQRL}	As above, except S21 = sine wave (200 mVp-p, f = 3.8 MHz), taking V _{EQRC} as the reference (0 dB)	8	11	14	dB
Record equalization characteristics (3)	G _{EQRH}	As above, except S21 = sine wave (200 mVp-p, f = 4.8 MHz), taking V _{EQRC} as the reference (0 dB)	8	11	14	dB
Record chrominance signal output level	V _{OR}	SW1 = on, V1 = 5 V, V5 = V6 = 0 V, V16 = 0 V, S15 = sine wave (200 mVp-p, f = 4.4 MHz), SW21B = on, S27 = composite sync.	80	110	140	mVp-p
Record chrominance signal output unnecessary spectrum (1)	G _{SR1}	As above, except measure the 2.2 MHz component in the T11 signal. Taking V _{OR} as the reference (0 dB).		-30	-20	dB
Record chrominance signal output unnecessary spectrum (2)	G _{SR2}	As above, except measure the 3.3 MHz component in the T11 signal. Taking V _{OR} as the reference (0 dB).		-30	-20	dB
Playback mode current drain	I _{CCP}	V5 = V6 = 0 V, V16 = 5 V, S27 = composite sync., S13 = sine wave (50 mVp-p, f = 1.0715 MHz)	60	80	100	mA
AGC control characteristics (1)	V _{AGC}	V6 = 5 V, SW8B = on, V16 = 5 V, S27 = composite sync., S13 = sine wave (50 mVp-p, f = 1.0715 MHz)	90	120	150	mVp-p
AGC control characteristics (2)	G _{AGC1}	As above, except S13 = sine wave (100 mVp-p, f = 1.0715 MHz). Taking V _{AGC} as the reference (0 dB).	-1	0	+1	dB
AGC control characteristics (3)	G _{AGC2}	As above, except S13 = sine wave (25 mVp-p, f = 1.0715 MHz). Taking V _{AGC} as the reference (0 dB).	-1	0	+1	dB
1.1-MHz band-pass filter characteristics (1)	G _{F1L}	V6 = 5 V, SW14 = on, V14 = V14R, S13 = sine wave (50 mVp-p, f = 500 kHz), V16 = 5 V, S27 = composite sync., taking V _{AGC} as the reference (0 dB).	-3	0	+3	dB
1.1-MHz band-pass filter characteristics (2)	G _{F1H1}	As above, except S13 = sine wave (50 mVp-p, f = 2.2 MHz). Taking V _{AGC} as the reference (0 dB).		-30	-20	dB
1.1-MHz band-pass filter characteristics (3)	G _{F1H2}	As above, except S13 = sine wave (50 mVp-p, f = 3.3 MHz). Taking V _{AGC} as the reference (0 dB).		-35	-25	dB

Continued on next page.

LA7337

Continued from preceding page.

Parameter	Symbol	Conditions	Ratings			Unit
			min	typ	max	
Playback equalization center frequency (1)	F_{EQP1}	V6 = 0 V, SW8B = on, SW14 = on, V14 = V14R, S13 = sine wave (50 mVp-p, f = 1 to 1.2 MHz), V16 = 5 V, S27 = composite sync.	1.0608	1.0715	1.0822	MHz
Playback equalization center frequency (2)	F_{EQP2}	As above, except V6 = 4 V	1.0788	1.0895	1.1002	MHz
Playback equalization characteristics (1)	V_{EQPC}	V6 = 0 V, SW8B = on, SW14 = on, V14 = V14R, S13 = sine wave (50 mVp-p, f = FEQP1), V16 = 5 V, S27 = composite sync.	120	150	180	mVp-p
Playback equalization characteristics (2)	G_{EQPL}	As above, except S13 = sine wave (50 mVp-p, f = 950 kHz), taking V_{EQP} as the reference (0 dB).	-14	-11	-8	dB
Playback equalization characteristics (3)	G_{EQPH}	As above, except S13 = sine wave (50 mVp-p, f = 1.2 MHz), taking V_{EQP} as the reference (0 dB).	-14	-11	-8	dB
Playback bell center frequency (1)	F_{BLP1}	SW1 = on, V1 = 5 V, V5 = V6 = 0 V, SW8A = SW8B = on, V16 = 5 V, S27 = composite sync., S8 = sine wave (200 mVp-p, f = 1 to 1.2 MHz),	4.243	4.286	4.329	MHz
Playback bell center frequency (2)	F_{BLP2}	As above, except V5 = 4 V	4.493	4.536	4.579	MHz
Playback bell characteristics (1)	V_{BLPC}	SW1 = on, V1 = 5 V, V5 = V6 = 0 V, SW8A = SW8B = on, S8 = sine wave (200 mVp-p, f = FBLP × 1/4), V16 = 5 V, S27 = composite sync.	65	85	105	mVp-p
Playback bell characteristics (2)	G_{BLPL}	As above, except S8 = sine wave (200 mVp-p, f = 950 kHz), taking V_{BLPC} as the reference (0 dB).	8	11	14	dB
Playback bell characteristics (3)	G_{BLPH}	As above, except S8 = sine wave (200 mVp-p, f = 1.2 MHz), taking V_{BLPC} as the reference (0 dB).	8	11	14	dB
Playback chrominance signal output level	V_{OP}	SW1 = on, V1 = 5 V, V5 = V6 = 0 V, V16 = 5 V, S13 = sine wave (200 mVp-p, f = 1.1 MHz), SW8B = on, S27 = composite sync.	130	160	190	mVp-p
Playback chrominance signal output unnecessary spectrum (1)	GSP1	As above, except measure the 2.2 MHz component in the T17 signal. Taking V_{OP} as the reference (0 dB).		-25	-15	dB
Playback chrominance signal output unnecessary spectrum (2)	GSP2	As above, except measure the 3.3 MHz component in the T17 signal. Taking V_{OP} as the reference (0 dB).		-20	-10	dB
CLK input level	V_{CLK}	f = 4.433619 MHz	100	200	800	mVp-p
Synchronizing signal input threshold level	V_{THS}		1.8	2	2.2	V
Record mode sync gate start time (muting off)	T_{RGB}	SW1 = on, V1 = 5 V, V5 = V6 = 0 V, V16 = 0 V, S15 = sine wave (200 mVp-p, f = 4.286 MHz), SW21B = on, S27 = composite sync.	-0.3	+0.2	+0.7	μs
Record mode sync gate start time (muting on)	T_{RGBM}	As above, except SW2 = on	1.5	2	2.5	μs
Record mode sync gate release time	T_{RGE}	As above	4.5	5.0	5.5	μs
Record mode mute setting resistance	VTSP2		10	20	30	kΩ
Playback mode sync gate start time	T_{PGB}	SW1 = on, V5 = V6 = 0 V, SW8B = on, S13 = sine wave (50 mVp-p, f = 1.0715 MHz), V16 = 5 V, S27 = composite sync.	1.5	2	2.5	μs
Playback mode sync gate release time	T_{PGE}	As above	4.5	5.0	5.5	μs
BGP start time	T_{BGB}	V5 = 0 V, V6 = 5 V, SW21B = on, V16 = 0 V, S27 = composite sync.	6.0	6.5	7.0	μs
BGP amplitude	T_{BGW}	As above	2.0	2.5	3.0	μs
SECAM discriminator output resistance	R26	SW25 = on, V25 = 5 V	7	10	13	kΩ
Record mode SECAM discriminator characteristics (1)	V_{SCMR1}	V5 = V6 = 0 V, V16 = 0 V, SW21B = on, S27 = composite sync., S15 = SECAM color bar signal	4.5			V
Record mode SECAM discriminator characteristics (2)	V_{SCMR2}	As above, except S15 = PAL color bar signal			0.5	V

Continued on next page.

LA7337

Continued from preceding page.

Parameter	Symbol	Conditions	Ratings			Unit
			min	typ	max	
Playback mode phase detector output difference voltage (1)	V_{SCPD1}	$V5 = V6 = 0\text{ V}$, SW8B = on, $V16 = 5\text{ V}$, S27 = composite sync., S13 = sine wave (50 mVp-p, $f = 1.0625/1.1016\text{ MHz}$)	150	180		mV
Playback mode phase detector output difference voltage (2)	V_{SCPD2}	As above, except S13 = sine wave (50 mVp-p, $f = 627\text{ kHz}$)			100	mV
Playback mode SECAM discriminator characteristics (1)	V_{SCMP1}	$V16 = 5\text{ V}$, SW23 = SW24 = On	4.5			V
Playback mode SECAM discriminator characteristics (2)	V_{SCMP2}	$V16 = 5\text{ V}$, SW23 = SW24 = On			0.5	V
SECAM discriminator comparator threshold voltage	V_{TCOMP}	SW25 = On	3.2	3.5	3.8	V
Record/playback control threshold voltage	V_{TRP}		2.3	2.5	2.7	V
Forced SECAM mode threshold voltage	V_{THSM}	$V16 = 0\text{ V}$, SW25 = on, $V25 = 3\text{ V}$, S27 = composite sync., S15 = sine wave (200 mVp-p, $f = 4.286\text{ MHz}$)			4	V
Forced mute mode threshold voltage	V_{THMM}	$V16 = 0\text{ V}$, SW25 = on, $V25 = 4\text{ V}$, S27 = composite sync., S15 = sine wave (200 mVp-p, $f = 4.286\text{ MHz}$)	1			V
Reference voltage	V_{REG}		4.1	4.3	4.5	V

Standard Input Signal Levels

REC-IN (pin 15)	The 200 mVp-p ID component
PB-IN (pin 13)	50 mVp-p

Internal filter group delay times (reference values)

1.1 MHz BPF	460 ns (PB) 430 ns (REC)
2.2 MHz BPF	180 ns
4.3 MHz BPF	230 ns
4.3 MHz BPF	170 ns

[Record/playback mode settings]

Pin 16 = low → record mode

Pin 16 = high → playback mode

[Bell filter offset adjustment]

Increasing the pin 6 voltage increases the 1.1-MHz bell filter center frequency (f_0).

Increasing the pin 5 voltage increases the 4.3-MHz bell filter center frequency (f_0).

[Test mode settings]

The IC enters test mode if pin 6 is set to 5 V. The pin 5, 11, 17, and 26 outputs behave as follows in this mode.

Pin 5: The 4.43-MHz VCO output appears (However, note that a load of about 1 k Ω is required between this pin and V_{CC} .)

Pin 11: The 1.1-MHz band-pass filter output appears.

Pin 17: The 4.3-MHz band-pass filter output appears.

Pin 26: The BGP (used for SECAM discrimination, playback AGC, and record killer) can be monitored.

[Muting control table]

Voltage applied to pin 1	Output signal mode (pins 17 and 11)
4 V or higher	Forced SECAM
Open	AUTO (Uses the output of the internal discriminator)
1 V or lower	Forced mute mode

LA7337

Block Diagram

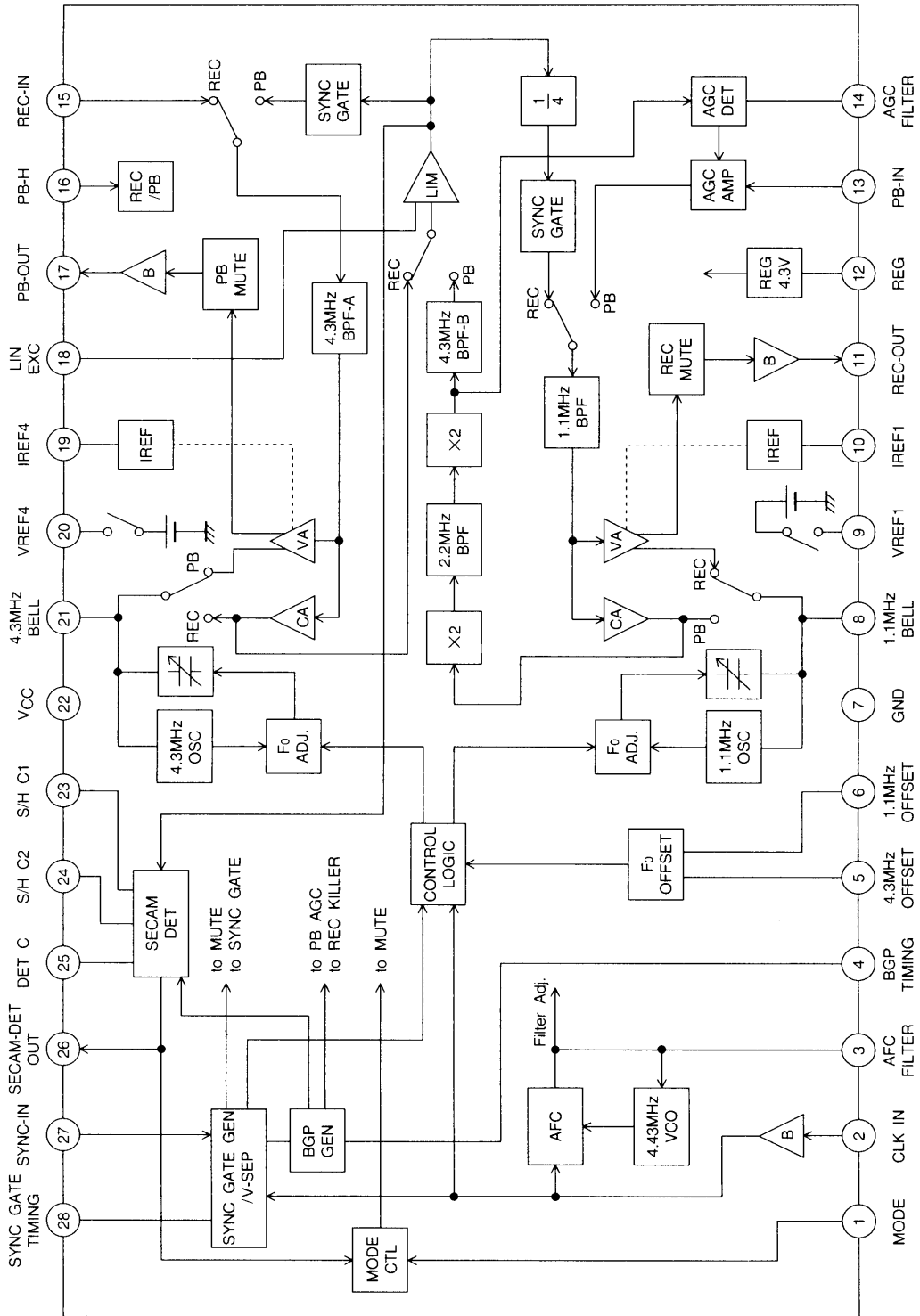

AO6251

LA7337

Test Circuit Diagram

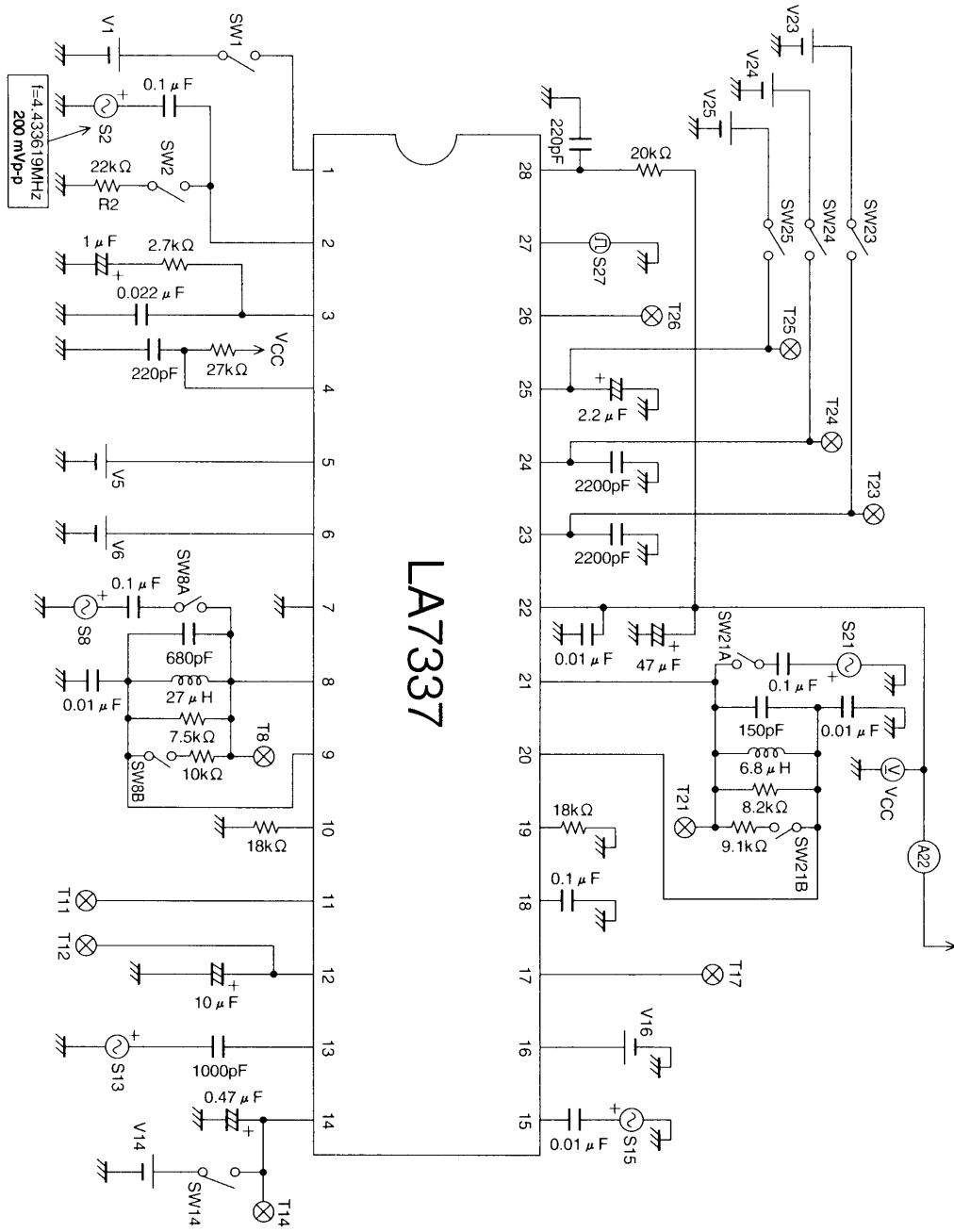

Note: Use an FET probe when measuring T8, T21, and BGP.

LA7337

Test Circuit Diagram

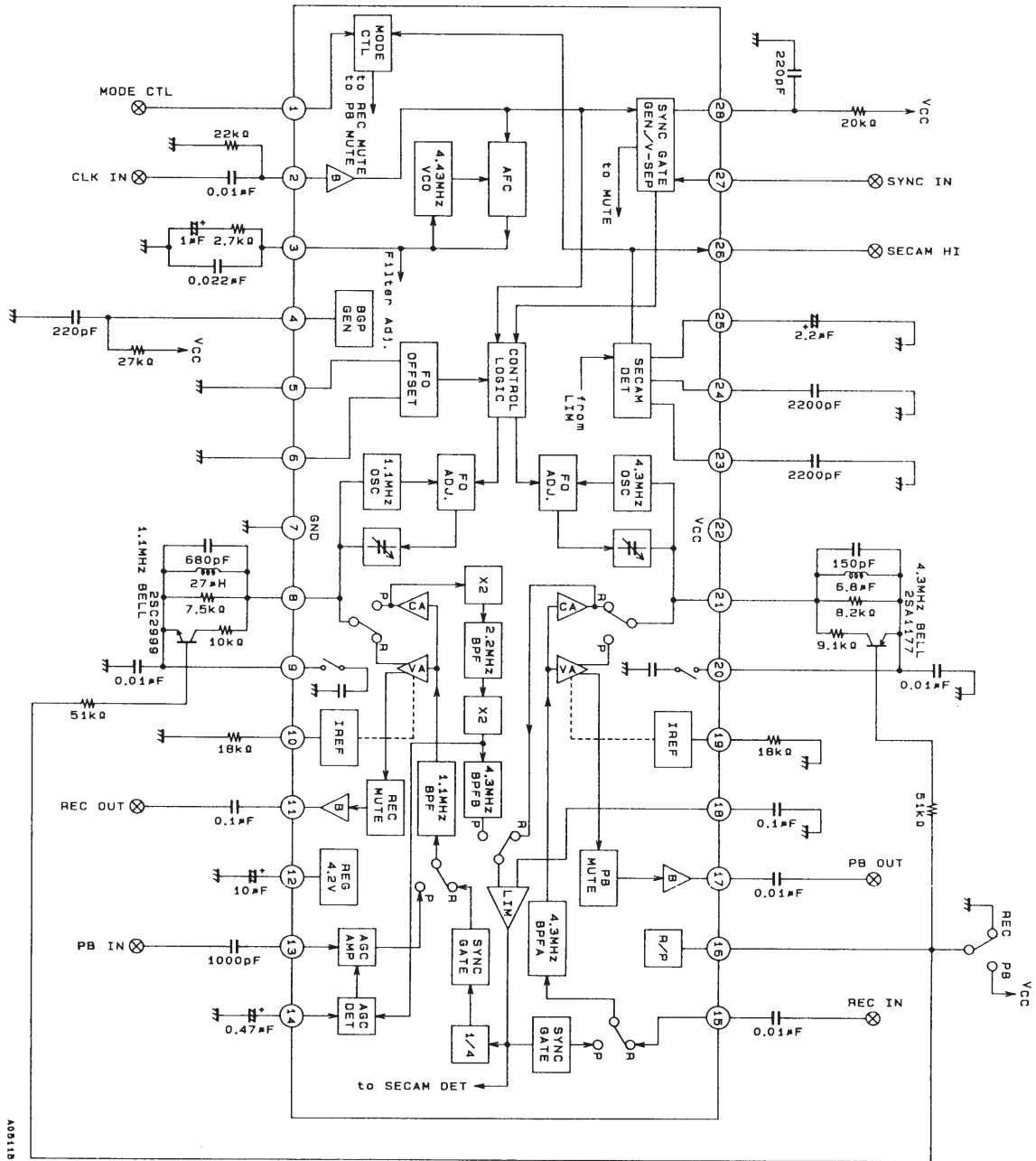

- No products described or contained herein are intended for use in surgical implants, life-support systems, aerospace equipment, nuclear power control systems, vehicles, disaster/crime-prevention equipment and the like, the failure of which may directly or indirectly cause injury, death or property loss.
- Anyone purchasing any products described or contained herein for an above-mentioned use shall:
 - ① Accept full responsibility and indemnify and defend SANYO ELECTRIC CO., LTD., its affiliates, subsidiaries and distributors and all their officers and employees, jointly and severally, against any and all claims and litigation and all damages, cost and expenses associated with such use:
 - ② Not impose any responsibility for any fault or negligence which may be cited in any such claim or litigation on SANYO ELECTRIC CO., LTD., its affiliates, subsidiaries and distributors or any of their officers and employees jointly or severally.
- Information (including circuit diagrams and circuit parameters) herein is for example only; it is not guaranteed for volume production. SANYO believes information herein is accurate and reliable, but no guarantees are made or implied regarding its use or any infringements of intellectual property rights or other rights of third parties.

This catalog provides information as of January, 1997. Specifications and information herein are subject to change without notice.