

SANYO	No. 5118A	Monolithic Linear IC LA7440, 7440M Video Signal Processing IC for VHS VCR Systems
--------------	-----------	--

Overview

The LA7440, 7440M is a video signal processing single-chip IC that, except for the VHS format VCR SECAM chrominance signal, handles the PAL-G, B, I M and N, NTSC-M, 4.43 NTSC, MESECAM and NAP-G, B, I, M and N formats. IC internal trimming is used to make the LA7440, 7440M is completely adjustment free, and in combination with a special-purpose CCD (the LC89971, 89971M) it provides a significant reduction in external components, including the glass delay line. Thus the LA7440, 7440M can significantly reduce the signal processing board manufacturing costs. Furthermore, the LA7440, 7440M supports the NAP format (NTSC to PAL conversion) that is poised to become widespread in Europe, China and other markets.

Features

- Completely adjustment free
The AGC, carrier, deviation, and PB-Y level are adjustment free.
The YC record current can also be made adjustment free by using the LA7411, 7416 as the head amplifier.
- Support for NAP and PAL color array correction
Full modulation using a balanced modulator allows playback and conversion to PAL format of NTSC signals recorded on tape.
- Crosstalk exclusion in combination with a special-purpose CCD
Crosstalk can be excluded without using a glass delay line by combining the LA7440, 7440M with a special-purpose CCD (the LC89971, 89971M).
- Minimal number of external components
New built-in components:
 - Detail enhancer CR
 - C-trap in the Y low-pass filter
 - Crystal selector switch
 - Playback C low-pass filter

- High performance and multiple functions
 - Linear phase picture controller
 - Double high-pass noise canceller, high-speed AFC, DCC
 - New built-in functions
 - NAP circuit
 - AVNS (advanced vertical noise suppressor)
 - Automatic QH insertion
 - FM AGC
- Miniature package (48-pin QIP or DIP)

Package Dimensions

unit: mm

3149-DIP48S

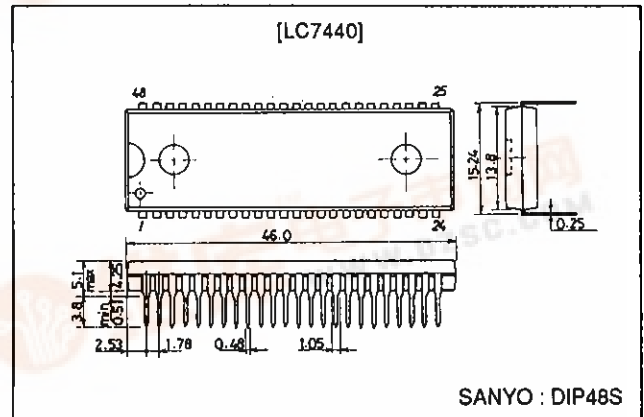

unit: mm

3156-QIP48E

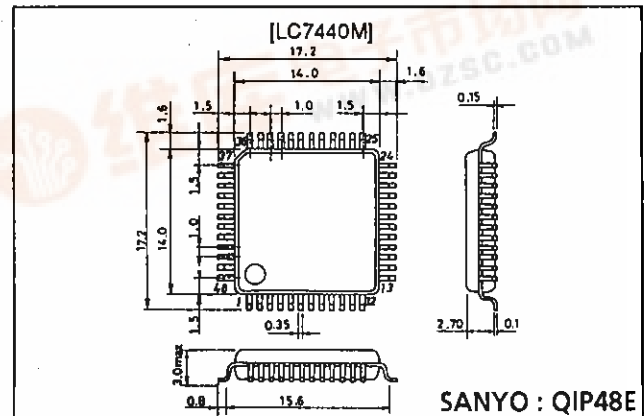

LA7440, 7440M

Functions

All VHS format VCR signal processing functions

	Luminance		Chrominance	
R/P	Video amp. Feedback clamp Main LPF YNR (AVNS) VCA Sync separator 4.2 V regulator		3.58 BPF/4.43 BPF ACC amp. ACC det. Main converter 1.3 M LPF VXO/XO Side lock det. 3rd lock protector	Half H killer BGP generator Killer det. VCO Phase shifter Sub converter 4.21/5.06BPF
REC	Video AGC amp. Video AGC det. Pre LPF Detail enhancer 1/2 f _H carrier shift	NL emphasis Main emphasis White/dark clip FM modulator	Pre amp. Burst emphasis (NTSC) Killer APC det. AFC det.	Burst gate amp.
PB	FM AGC amp. FM AGC det. Double limiter FM demodulator Sub LPF Double high pass noise canceller QV/QH/character insert Main de-emphasis DOC	Drop out det. NL de-emphasis Picture control Y/C mix	Pre amp. Burst de-emphasis (NTSC) PB amp. Killer NAP PAL burst sequence - Compensator Carrier balancer Burst gate amp.	APC det. ID det. DCC Trick det. DPLL

Specifications

Pin numbers are for the LA7440M

Maximum Ratings at Ta = 25°C

Parameter	Symbol	Conditions	Ratings	Unit
Maximum supply voltage	V _{CC} max		7.0	V
Allowable power dissipation	Pd max	LA7440	1150	mW
		LA7440M: Ta ≤ 65°C*	1350	
Operating temperature	T _{op}		-10 to +65	°C
Storage temperature	T _{stg}		-40 to +150	°C

Note: * When mounted on a 70 mm by 65 mm, 1.5 mm thickness Bakelite board. The value for the DIP package is 1150 mW.

Operating Conditions at Ta = 25°C

Parameter	Symbol	Conditions	Ratings	Unit
Recommended supply voltage	V _{CC}		5.0	V
Operating supply voltage	V _{CC} op		4.8 to 5.2	V

Operating Characteristics at Ta = 25°C, V_{CC} = 5.0 V

Parameter	Symbol	Conditions	min	typ	max	Unit
[Record Mode Y System]						
Record mode current drain	I _{CCR}	Input: 1.0 Vp-p video signal	100	130	160	mA
EE output level 1	V _{EE1}	Input: 50 Hz system 1.0 Vp-p video signal	1.95	2.05	2.15	Vp-p
EE output level 2	V _{EE2}	Input: 60 Hz system 1.0 Vp-p video signal	1.95	2.05	2.15	Vp-p
AGC characteristics 1	AGC1	Input: 50 Hz system 2.0 Vp-p video signal	2.05	2.15	2.25	Vp-p
AGC characteristics 2	AGC2	Input: 50 Hz system 0.5 Vp-p video signal	1.90	2.00	2.10	Vp-p
AGC characteristics 3	AGC3	Input: 50 Hz system with only SYNC increased 6 dB	555	615	695	mVp-p
AGC characteristics 4	AGC4	Input: 50 Hz system with only SYNC decreased 6 dB	370	410	450	mVp-p
Sync separator output level	V _{SVR}	The SYNC-OUT output pulse wave height	3.9	4.1	4.3	V
Sync separator output pulse width	PW _{SVR}	The SYNC-OUT output pulse width	4.0	4.3	4.6	μs
Sync separator output pre-record delay time	ΔT _{SVR}	The SYNC-OUT delay time	0.9	1.1	1.3	μs
Sync separator threshold level	TH _{SVR}			-20	-15	dB

Continued on next page.

LA7440, 7440M

Continued from preceding page.

Parameter	Symbol	Conditions	min	typ	max	Unit
[Record Mode Y System]						
Pseudo-H insertion level	ΔHD_R	With 2.7 V applied to T14A	-400	-300	-200	mV
White insertion level	ΔWH_R	With 1.3 V applied to T14A	100	250	400	mV
VCA detection voltage	V_{VCA}		3.00	3.20	3.40	V
Record YNR operation EP/LP	V_{R-YNR1}	Input: 50 Hz system standard color bar signal	10	12	14	mVp-p
Y-LPF frequency characteristics 1	YLPF1	The 1 MHz attenuation with respect to 500 kHz; 3.58 system	-0.5	0.0	+0.5	dB
Y-LPF frequency characteristics 2	YLPF2	The 2 MHz attenuation with respect to 500 kHz; 3.58 system	-1.0	0.0	+1.0	dB
Y-LPF frequency characteristics 3	YLPF3	The 3 MHz attenuation with respect to 500 kHz; 3.58 system	-9	-7	-5	dB
Y-LPF frequency characteristics 4	YLPF4	The 3.58 MHz attenuation with respect to 500 kHz; 3.58 system			-25	dB
Y-LPF frequency characteristics 5	YLPF5	The 4.2 MHz attenuation with respect to 500 kHz; 3.58 system			-15	dB
Y-LPF frequency characteristics 6	YLPF6	The 4.43 MHz attenuation with respect to 500 kHz; 4.43 system			-25	dB
FM modulator output level	V_{FM}	No input	1.0	1.2	1.4	Vp-p
Carrier frequency 1	F_{FM1}	50 Hz system	3.7	3.8	3.9	MHz
Carrier frequency 2	F_{FM2}	60 Hz system	3.3	3.4	3.5	MHz
FM modulator output 2nd harmonic distortion	H_{MOD}			-40	-35	dB
Deviation 1	DEV1	50 Hz system	0.95	1.00	1.05	MHz
Deviation 2	DEV2	60 Hz system	0.95	1.00	1.05	MHz
FM modulator linearity	L_{MOD}		-2	0	+2	%
1/2 f_H carrier shift	CS		6.5	7.8	9.1	kHz
Emphasis gain	G_{EMP}	Input: 0.5 Vp-p, 10 kHz sine wave	-0.5	0.0	+0.5	dB
Detail enhancer characteristics 1	G_{DET1}	Input: 158 mVp-p, 2 MHz sine wave	1.6	1.9	2.6	dB
Detail enhancer characteristics 2	G_{DET2}	Input: 50 mVp-p, 2 MHz sine wave	3.1	4.1	5.1	dB
Detail enhancer characteristics 3	G_{DET3}	Input: 15.8 mVp-p, 2 MHz sine wave	5.3	6.3	7.3	dB
NL emphasis characteristics 1	G_{NLEMP1}	Input: 500 mVp-p, 2 MHz sine wave	0.5	1.4	2.3	dB
NL emphasis characteristics 2	G_{NLEMP2}	Input: 158 mVp-p, 2 MHz sine wave	2.6	3.8	5.2	dB
NL emphasis characteristics 3	G_{NLEMP3}	Input: 50 mVp-p, 2 MHz sine wave	4.9	6.4	7.9	dB
Main emphases characteristics 1	G_{ME1}	Input: 100 mVp-p, 500 kHz sine wave	4.9	5.2	5.5	dB
Main emphases characteristics 2	G_{ME2}	Input: 100 mVp-p, 2 MHz sine wave	13.1	13.6	14.1	dB
White clipping level	L_{WC}	Input: 1.0 Vp-p, white 100% video signal	186	195	204	%
Dark clipping level	L_{DC}	Input: 1.0 Vp-p, white 100% video signal	-55	-50	-45	%
[Playback Mode Y System]						
Playback mode current drain	I_{CCP}		135	160	185	mA
Dropout compensation time	T_{DOC}		0.72	0.85	0.98	ms
DOC loop gain	G_{DOC}	5H later	-1.0	0.0	+1.0	dB
Playback Y level	V_{VOUT}	For playback of an FM signal with a 1.0 MHz deviation	1.95	2.05	2.15	Vp-p
FM demodulator linearity	L_{DEM}	2, 4, 6 MHz	-3.5	0.0	+3.5	%
Demodulation sensitivity	S_{DEM}		0.47	0.52	0.57	V/MHz
Carrier leakage	CL	Input: 4 MHz, 600 mVp-p		-40	-35	dB
Playback YNR characteristics LP/EP	G_{P-YNR1}	Input: 50% white + CW	-2.5			dB
NL de-emphasis characteristics 1	G_{NLDE1}	Input: 158 mVp-p, 2 MHz sine wave	-6.0	-5.0	-4.0	dB
NL de-emphasis characteristics 2	G_{NLDE2}	Input: 50 mVp-p, 2 MHz sine wave	-10.5	-9.0	-7.5	dB
Double noise canceller characteristics 1	G_{WN1}	Input: 158 mVp-p, 2 MHz sine wave	-2.3	-1.8	-1.3	dB
Double noise canceller characteristics 2	G_{WN2}	Input: 50 mVp-p, 2 MHz sine wave	-6.0	-5.0	-4.0	dB
Double noise canceller characteristics 3	G_{WN3}	Input: 15.8 mVp-p, 2 MHz sine wave	-10.5	-9.0	-7.5	dB
PIC-CTL hard response characteristics 1	G_{PH1}	Input: 50% video + sine wave $f = 1$ MHz, 158 mVp-p	4.5	5.5	6.5	dB

Continued on next page.

LA7440, 7440M

Continued from preceding page.

Parameter	Symbol	Conditions	min	typ	max	Unit
[Record Mode Y System]						
PIC-CTL hard response characteristics 2	G _{PH2}	Input: 50% video + sine wave f = 2 MHz, 158 mVp-p	8.0	9.0	10.0	dB
PIC-CTL soft response characteristics 1	G _{PS1}	Input: 50% video + sine wave f = 1 MHz, 158 mVp-p	-4.5	-3.5	-2.5	dB
PIC-CTL soft response characteristics 2	G _{PS2}	Input: 50% video + sine wave f = 2 MHz, 158 mVp-p	-9.0	-7.0	-5.0	dB
Pseudo-V insertion level (playback)	Δ VDP	With 5 V applied to T14A	-150	-50	+50	mV
Pseudo-H insertion level (playback)	Δ HDP	With 2.7 V applied to T14A	-400	-300	-200	mV
White insertion level (playback)	Δ WHp	With 1.3 V applied to T14A	100	250	400	mV
Sync separator output level	V _{SYP}	The SYNC-OUT output pulse wave height	3.9	4.1	4.3	V
Sync separator output pulse width	PW _{SYP}	The SYNC-OUT output pulse width	4.2	4.5	4.8	μ s
Sync separator output prerecord delay time	Δ T _{SYP}		1.4	1.6	1.8	μ s
4.2 V regulator voltage	V _{REG}		4.0	4.2	4.4	V
[Record Mode Chrominance System]						
Chrominance low band conversion output burst level	V _{OR-38}	Input: PAL/GBI standard color bar signal, 1 Vp-p	150	190	230	mVp-p
Burst enhancement level	G _{BE}	Input: NTSC standard color bar signal, 1 Vp-p, SP/EP	5.5	6.0	6.5	dB
VXO oscillator level 1	V _{VXO-R1}	Input: NTSC standard color bar signal, 1 Vp-p	300	500	700	mVp-p
VXO oscillator level 2	V _{VXO-R2}	Input: PAL/GBI standard color bar signal, 1 Vp-p	300	500	700	mVp-p
Record ACC characteristics 1	ACC _{R1}	With only the chrominance signal level increased 6 dB		+0.2	+0.6	dB
Record ACC characteristics 2	ACC _{R2}	With only the chrominance signal level decreased 6 dB	-0.5	-0.1		dB
ACC killer on input level	V _{ACCK-ON}			-26		dB
ACC killer on output level	V _{O-ACCK}			-60	-50	dB
ACC killer recovery input level	V _{ACCK-OFF}			-20		dB
VXO control sensitivity	S _{VXO}		1.3	3.2	5.1	Hz/mV
APC pull-in range 1	Δ f _{APC1}		350			Hz
APC pull-in range 2	Δ f _{APC2}				-350	Hz
BGP delay time	t _D	Input: PAL/GBI standard color bar signal, 1 Vp-p	3.1	3.4	3.7	μ s
BGP pulse width	t _W		4.7	4.9	5.1	μ s
AFC pull-in range 1	Δ f _{AFC1}		+1.0	+7.0		kHz
AFC pull-in range 2	Δ f _{AFC2}			-3.7	-1.0	kHz
YC separation capability (NTSC)	V _{OR25}	Input: 50% white + 3.571678 MHz			-20	dB
[Playback Mode Chrominance System]						
Video output burst level	V _{OP-11}	SP mode, input: burst 30 mVp-p	255	300	345	mVp-p
Pin 25 output burst level	V _{OP-25}	SP mode, input: burst 30 mVp-p	195	230	265	mVp-p
Playback ACC characteristics 1	ACC _{P1}	With the chrominance level increased 6 dB		+0.5	+0.8	dB
Playback ACC characteristics 2	ACC _{P2}	With the chrominance level decreased 6 dB	-0.8	-0.5		dB
Playback killer on input level	V _{ACK-P}		-40	-32	-25	dB
Playback killer on chrominance output level	V _{OACK-P}			-44	-40	dB
Main converter carrier leakage	C _{LP}	The 5.06 MHz carrier leakage component		-40	-33	dB
Burst deemphasis level NT	G _{BD}	NTSC mode	-5.25	-5.0	-4.75	dB
Playback XO output level 1	V _{XO-P1}		300	450	600	mVp-p
Playback XO output level 2	V _{XO-P2}		300	450	600	mVp-p
Playback XO oscillator frequency deviation	Δ f _{XO}	Δ f _{XO} = f - 4.433619 (MHz)	-9	0	+9	Hz
SLD detector current 1	I _{SLD1}			170		μ A
SLD detector current 2	I _{SLD2}			170		μ A
NTSC playback burst output level	V _{BNT}	NTSC mode	255	300	345	mVp-p
NTSC to PAL conversion - V axis burst level	VB-NAP		-1.0	0.0	+1.0	dB
NTSC to PAL conversion burst level ratio	Δ B-NAP		-2.0	0.0	+2.0	dB

LA7440, 7440M

L7440M Control Pin Table

Pin No.	Control function		L		M		H	
3	R/P	Edit					3.8 VDC or more	
5	R/P	YNR (AVNS)-CTL	1.0 VDC or less YNR-off		1.5 to 2.5 VDC YNR-CTL		3.5 VDC or more YNR (strong)	
6	R	*****					3.9 VDC or more	
	P	N. C. CTL	1.5 VDC or less N. C-off		2.0 to 3.0 VDC N. C-CTL			
12	R/P	C-rotary	0 to 1.9 VDC Low CH			2.3 VDC or more High CH		
14	P	QV/QH CHARA. INS	0.8 VDC or less Through	1.2 to 2.2 VDC CHARA insert	2.6 to 3.3 VDC Pedestal insert	3.7 VDC or more QV insert		
15	P	Auto QH INS on	Pull down by 3.9 kΩ					
18	R/P	E-MM	1.6 V or less E-M (50 Hz)			2.0 V or more M (60 MHz)		
		N. L.-on (weak)	0.6 VDC or less N. L.-off		1.0 to 3.0 VDC N. L.-on		3.9 VDC or more N. L.-off	
	R	Detail-ENHA	Normal		Weak and f _c down		Normal	
22	R/P	EP/LP/SP	1.2 VDC or less SP		2.0 to 2.7 VDC LP		3.9 VDC or more EP	
23	R	SP carrier shift stop					3.0 VDC or more SP carrier shift stop	
24	P	NAP	1.2 VDC or less Through		2.0 to 2.7 VDC Balanced-mod output		3.3 VDC or more NAP-on	
26	R/P	NT/MESEC/PAL	1.2 VDC or less PAL		2.0 to 2.7 VDC MESEC		3.9 VDC or more NTSC	
29	P	Trick					3.9 VDC or more	
35	R/P	Filter-change	2.0 VDC or less			3.0 VDC or more		
44	P	DOC-off					4.1 VDC or more	
48	R/P	PB-H					4.0 VDC or more	

Note: Do not allow pin 3 to fall under 1.5 V. (The chip will enter test mode.)

Function Control In each of the LA7440M Operating Modes

		Edit	YNR			NL		Detail enhancer			NC			PIC-CTL	1/2 f _H carrier shift
			Pin 5 control			Pin 18 control		Pin 6 control (with pin 18 control L/H)			Pin 6 control				
			L	M	H	L/H	M	L	M	H	L	M	H		
REC	SP	On	Off	Off	Off	Off	On	Off	Variable	Center	—	—	—	—	○ (X)
		Off	Off	Off	Off	Off	On	Off	Variable	Center	—	—	—	—	○ (X)
	LP EP	On	Off	K1 = 0.2 K2 = 0.0	K1 = 0.2 K2 = 0.0	On	On	Off	Variable	Center	—	—	—	—	○
		Off	Off	K1 = 0.5 K2 = 0.0	K1 = 0.5 K2 = 0.0	On	On	Off	Variable	Center	—	—	—	—	○
PB	SP	On	K1 = 0.0 K2 = 0.0	K1 = 0.0 K2 = 0.0	K1 = 0.5 K2 = 0.0	Off	On	—	—	—	Off	Variable	Center	Center	—
		Off	K1 = 0.0 K2 = 0.0	K1 = 0.2 K2 = 0.0	K1 = 0.5 K2 = 0.0	Off	On	—	—	—	Off	Variable	Center	○	—
	LP EP	On	K1 = 0.0 K2 = 0.5	K1 = 0.2 K2 = 0.5	K1 = 0.5 K2 = 0.5	On	On	—	—	—	Off	Variable	Center	Center	—
		Off	K1 = 0.0 K2 = 0.5	K1 = 0.2 K2 = 0.5	K1 = 0.5 K2 = 0.5	On	On	—	—	—	Off	Variable	Center	○	—

- Note: 1. K1 is the YNR coefficient, K2 is the LNC coefficient
 2. Use the 1/2 f_H carrier shift entries in parentheses when pin 23 is high.
 3. The detail enhancer is off when pin 18 is at the middle level.

LA7440, 7440M

LA7440 Test Circuit

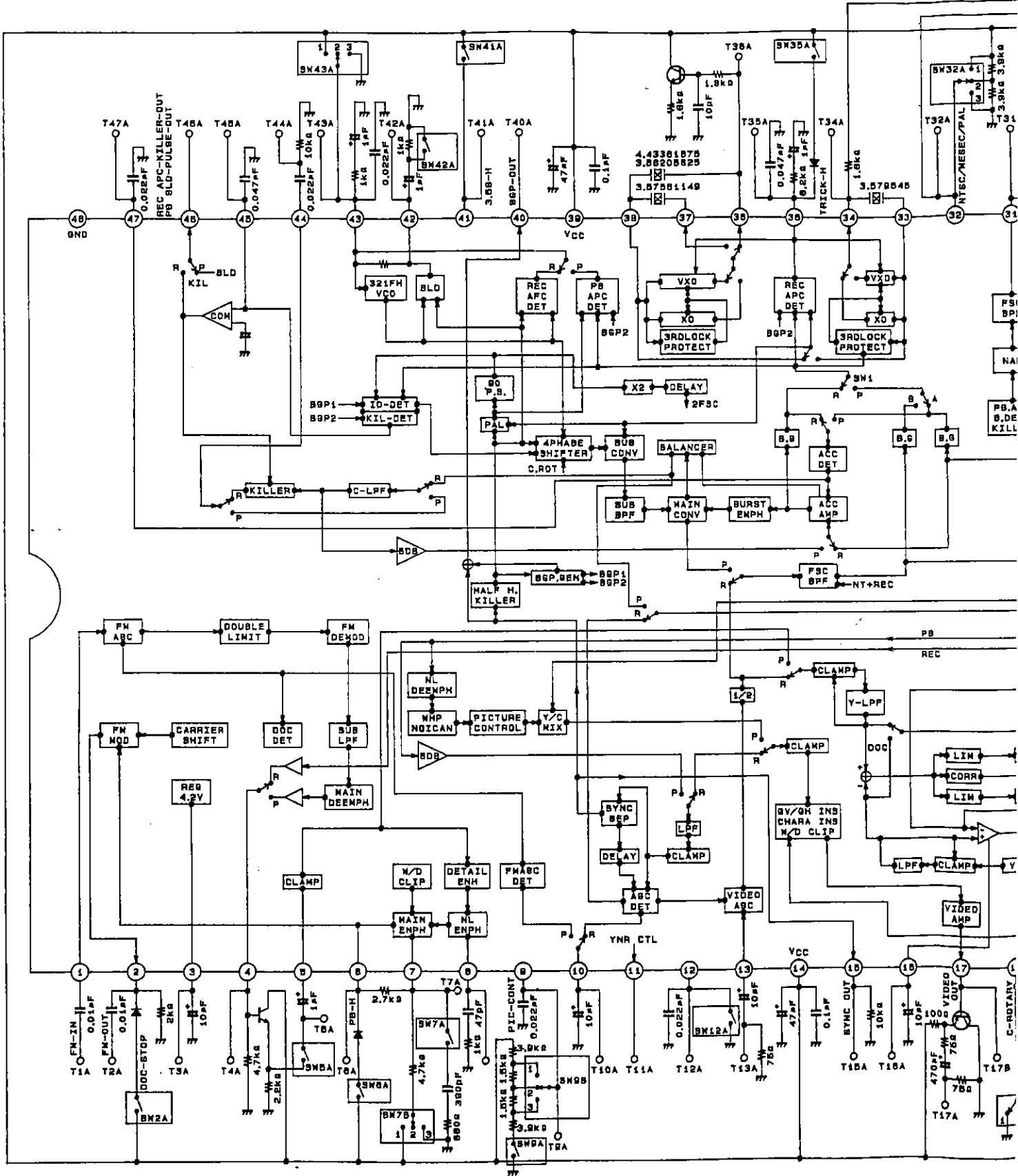

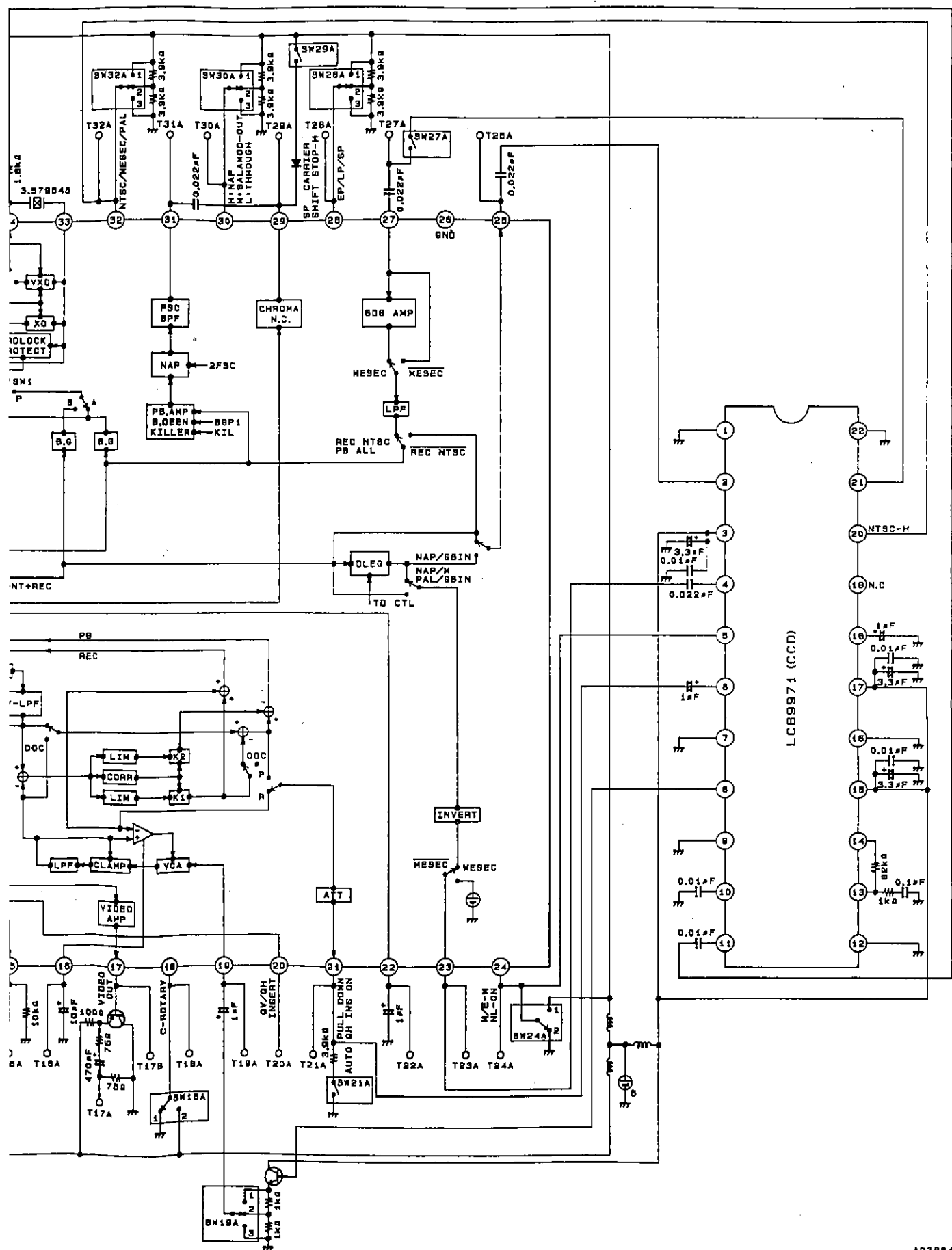

LA7440, 7440M

LA7440 Block Diagram

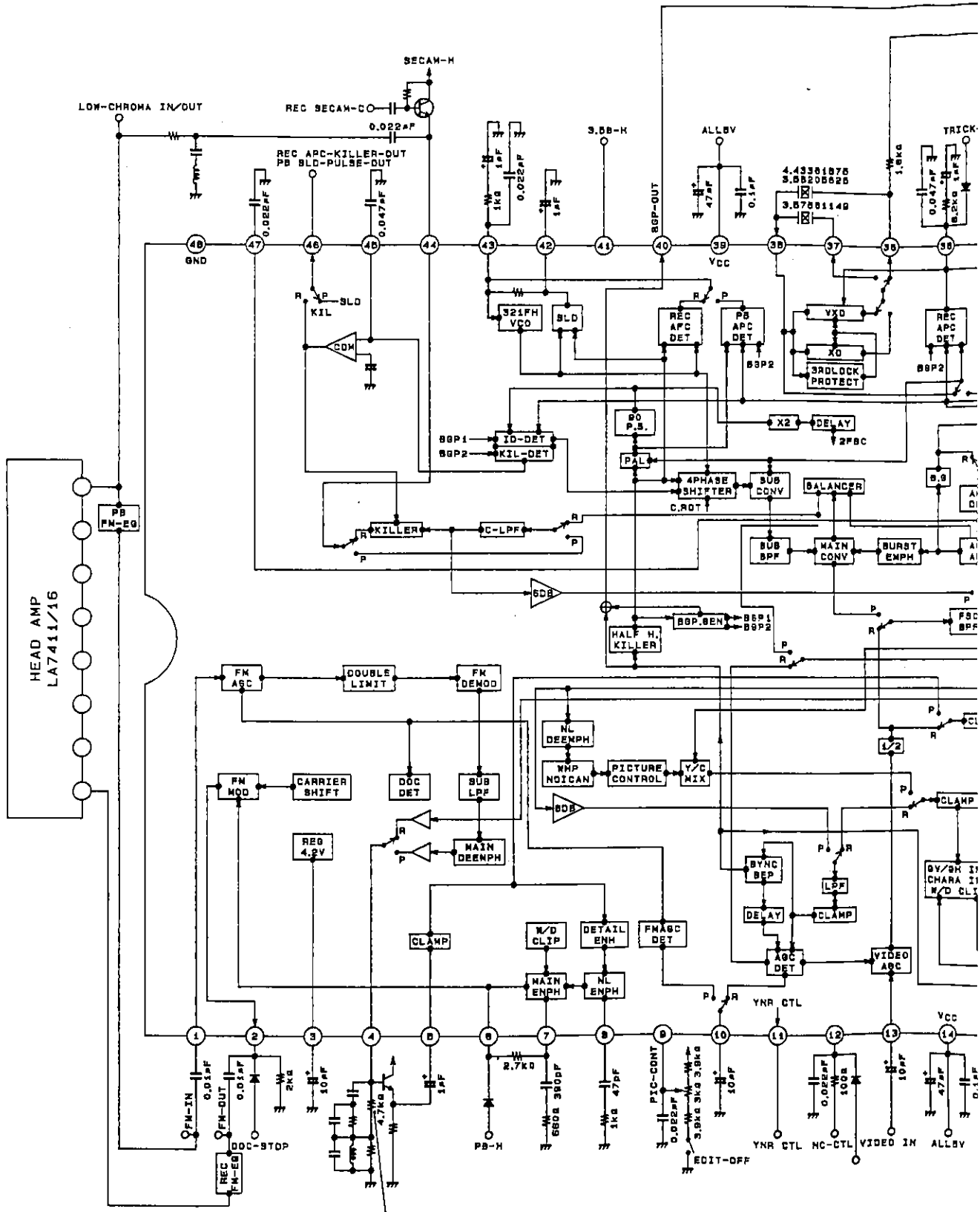

We recommend using a $\pm 1\%$ tolerance resistor here since this resistor determines the PB-Y level.

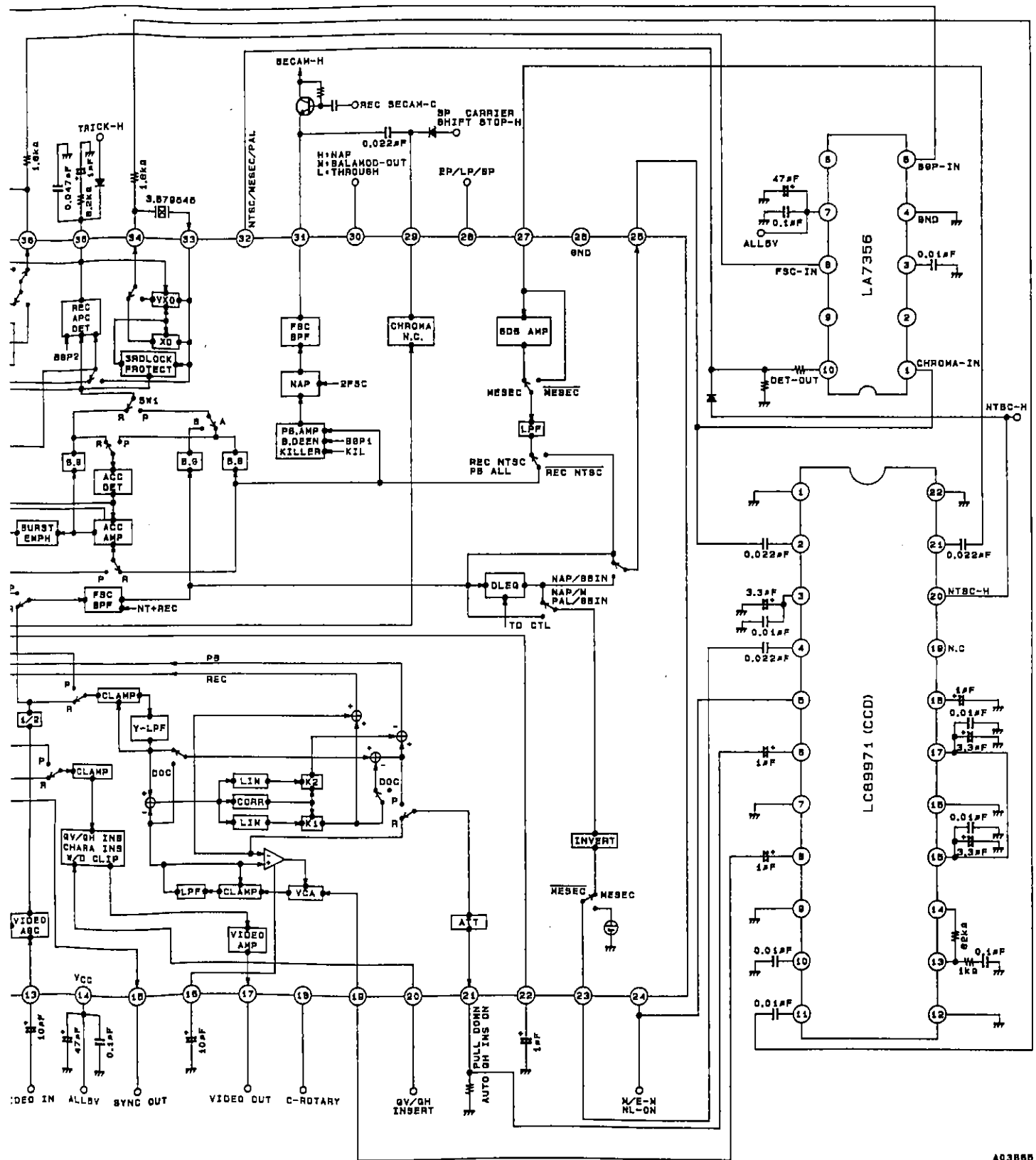

LA7440, 7440M

LA7440M Test Circuit

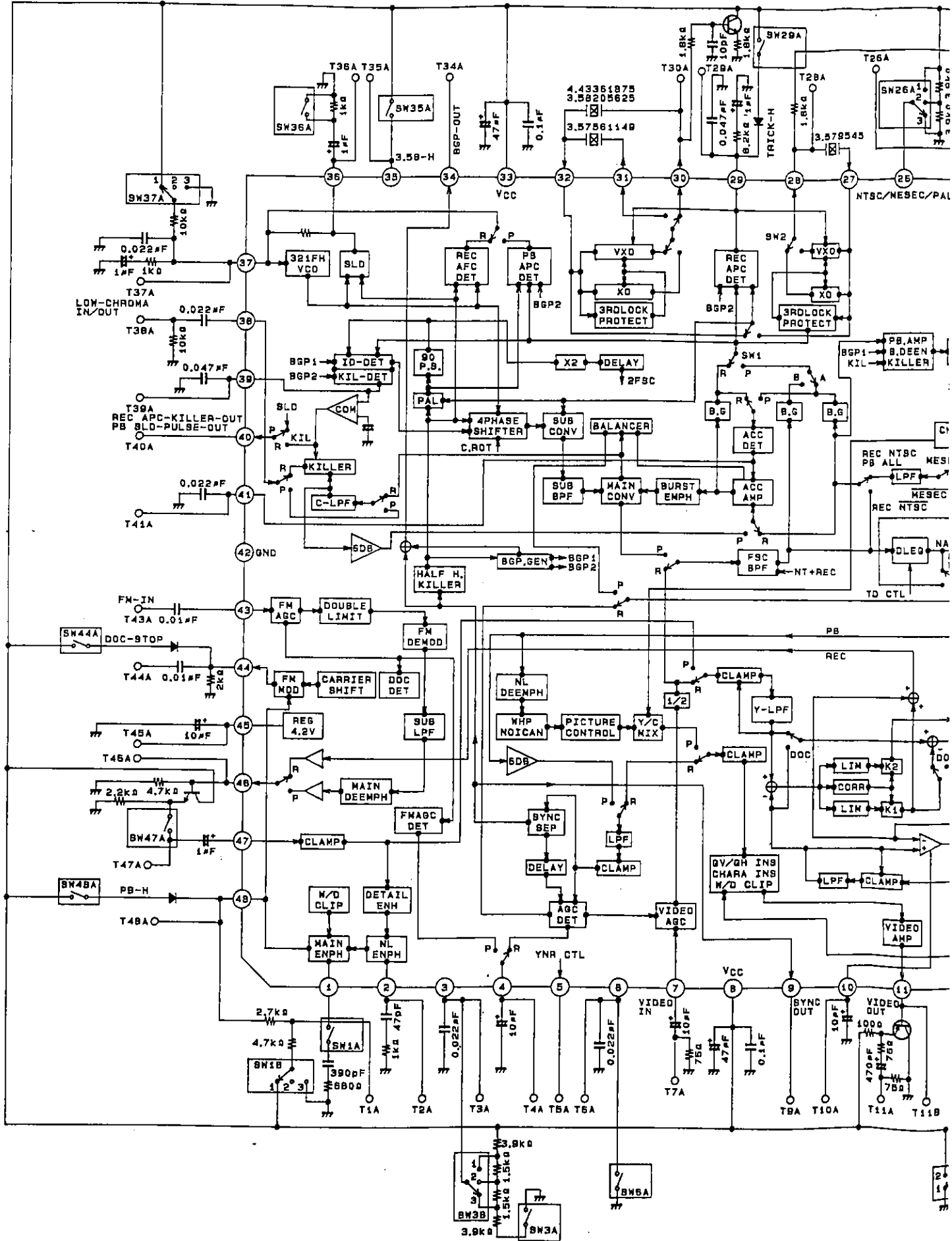

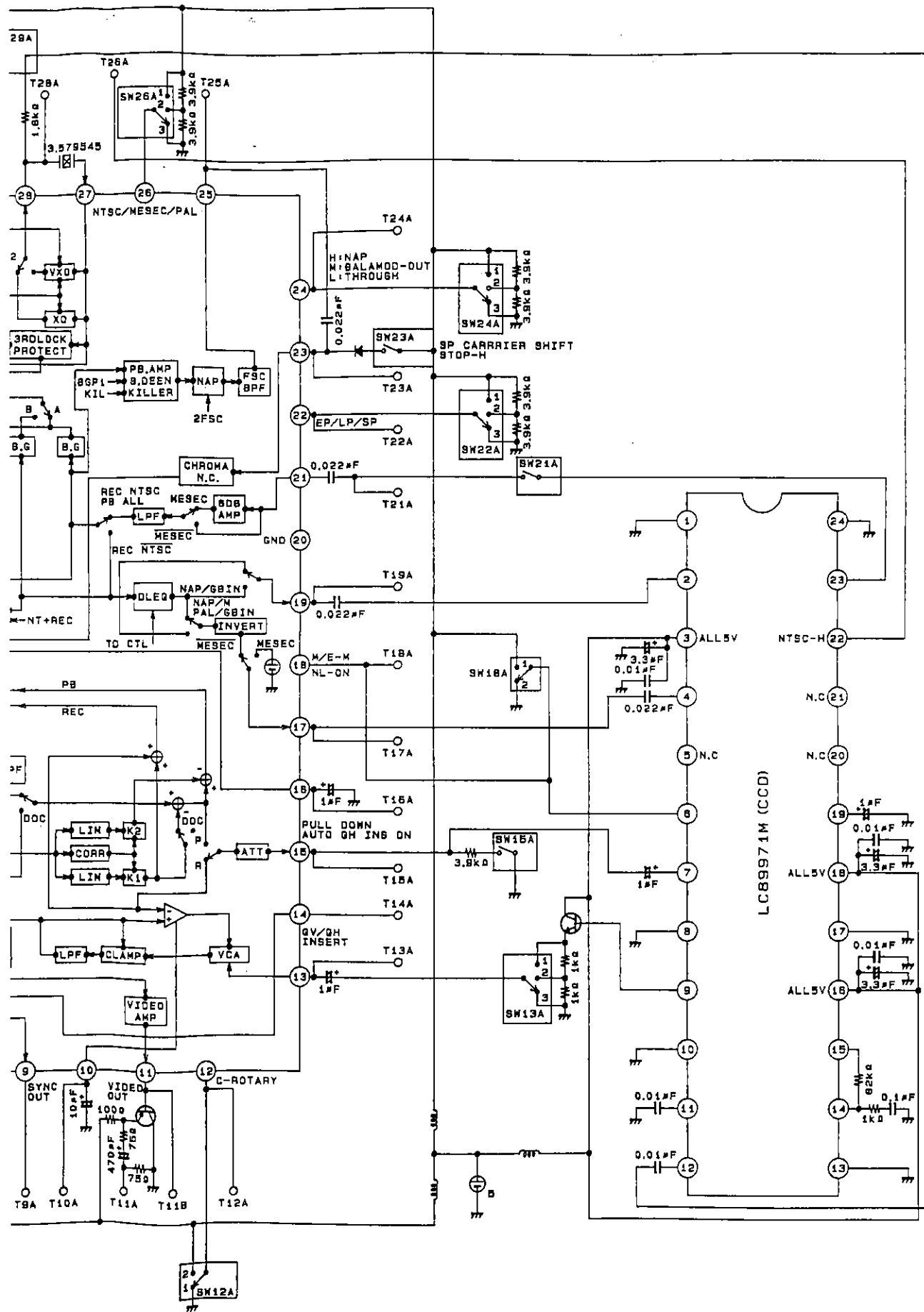

LC89971M (CCD)

LA7440, 7440M

LA7440M Block Diagram

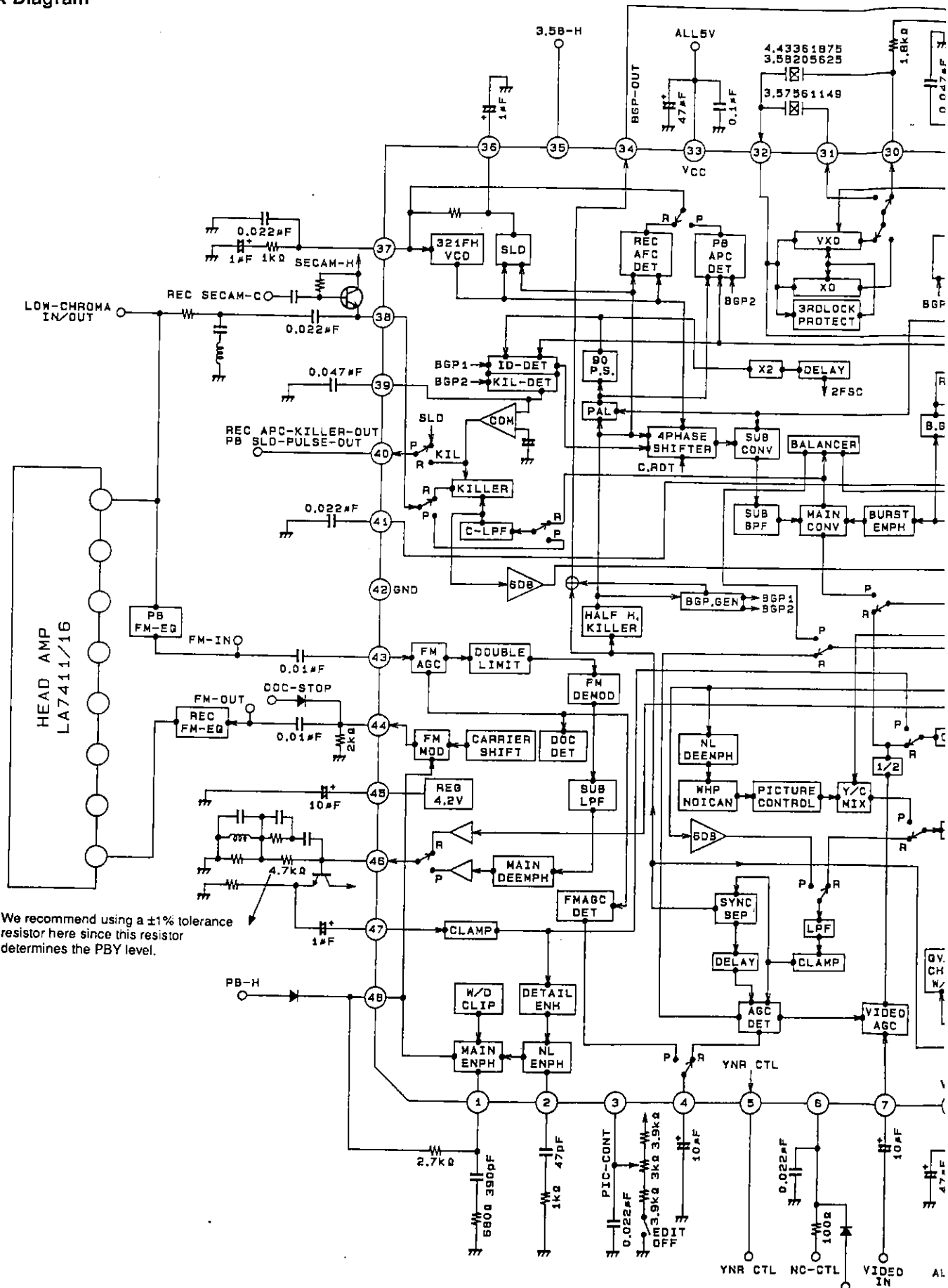

We recommend using a ±1% tolerance resistor here since this resistor determines the PBY level.

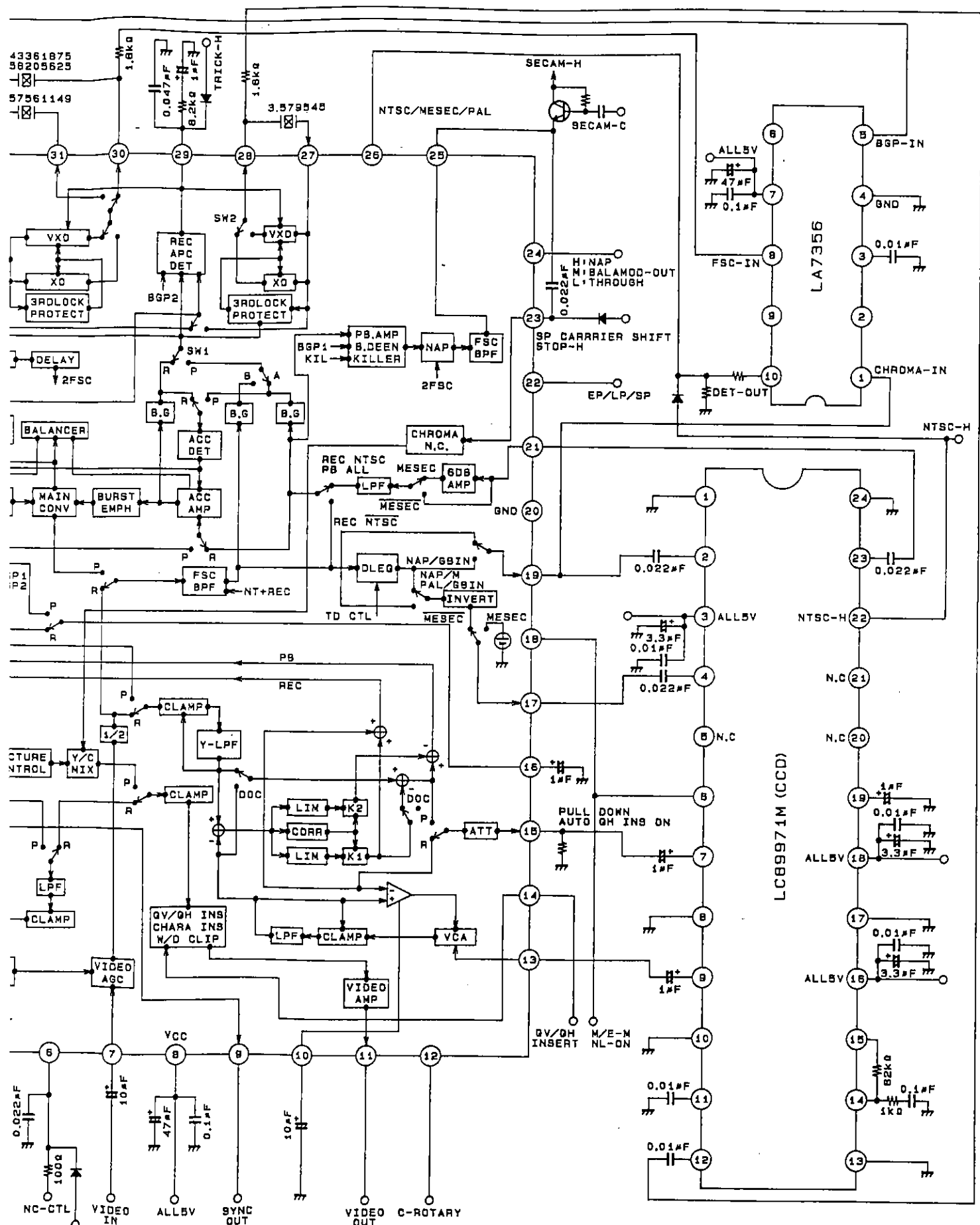

- No products described or contained herein are intended for use in surgical implants, life-support systems, aerospace equipment, nuclear power control systems, vehicles, disaster/crime-prevention equipment and the like, the failure of which may directly or indirectly cause injury, death or property loss.
- Anyone purchasing any products described or contained herein for an above-mentioned use shall:
 - ① Accept full responsibility and indemnify and defend SANYO ELECTRIC CO., LTD., its affiliates, subsidiaries and distributors and all their officers and employees, jointly and severally, against any and all claims and litigation and all damages, cost and expenses associated with such use:
 - ② Not impose any responsibility for any fault or negligence which may be cited in any such claim or litigation on SANYO ELECTRIC CO., LTD., its affiliates, subsidiaries and distributors or any of their officers and employees jointly or severally.
- Information (including circuit diagrams and circuit parameters) herein is for example only; it is not guaranteed for volume production. SANYO believes information herein is accurate and reliable, but no guarantees are made or implied regarding its use or any infringements of intellectual property rights or other rights of third parties.

This catalog provides information as of January, 1996. Specifications and information herein are subject to change without notice.