



## Overview

The LA7471M is a stereo microphone amplifier for use in video camera products. It includes an automatic wind noise detection and removal circuit, an equalization circuit to compensate for microphone frequency characteristics and an L/R mixing circuit to provide a good stereo image. The LA7471M provides high quality audio for video camera applications.

## Functions

- Microphone amplifier (two channels)
- Internal/external microphone switching
- Automatic wind noise detection/prevention circuit
- High-pass filter and disable switch
- Internal microphone power supply
- External microphone power supply (with current limiter)
- Ripple filter
- Stereo/mono detection for external microphones

## Features

- Automatic wind noise detection and exclusion circuit (The high-pass filter provides a first-order to third-order linear conversion.)
- High-quality audio (low noise, microphone frequency characteristic compensation, and stereo enhancement)

## Specifications

### Maximum Ratings at Ta = 25°C

Parameter	Symbol	Conditions	Ratings	Unit
Maximum supply voltage	V <sub>CC</sub> max		7.0	V
Allowable power dissipation	P <sub>d</sub> max	Ta ≤ 65°C	300	mW
Operating temperature	T <sub>opr</sub>		-10 to +65	°C
Storage temperature	T <sub>stg</sub>		-55 to +150	°C

### Operating Conditions at Ta = 25°C

Parameter	Symbol	Conditions	Ratings	Unit
Recommended supply voltage	V <sub>CC</sub>		5.0	V
Operating supply voltage range	V <sub>CC</sub> op		4.5 to 5.5	V

## Package Dimensions

unit: mm

### 3162B-QFP36

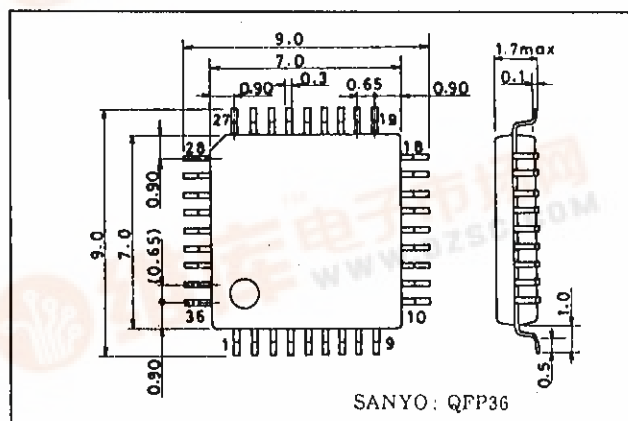

## LA7471M

**Operating Characteristics at  $T_a = 25^\circ\text{C}$ ,  $V_{CC} = 5.0\text{ V}$ ,  $f = 1.0\text{ kHz}$ ,  $R_L = 10\text{ k}\Omega$**

Parameter	Symbol	Conditions	Ratings			Unit
			min	typ	max	
Current dissipation	$I_{CC1}$	INT MIC in, EXT $V_{CC}$ off, L/Rch	5.5	8	10.5	mA
	$I_{CC2}$	INT MIC in, EXT $V_{CC}$ on, L/Rch	6	9	12	mA
Voltage gain	$VG_1$	EXT MIC in, L/Rch	27.3	27.8	28.3	dB
	$VG_2$	INT MIC in, Gain CTL Hi, L/Rch	23.8	24.3	24.8	dB
	$VG_3$	INT MIC in, Gain CTL Mi, L/Rch	20.8	21.3	21.8	dB
	$VG_4$	INT MIC in, Gain CTL Lo, L/Rch	17.8	18.3	18.8	dB
Total harmonic distortion	THD	INT MIC in, EXT MIC in $V_O = 300\text{ mVrms}$ , L/Rch		0.05	0.2	%
Maximum output	$V_{OM}$	INT MIC in, EXT MIC in THD = 1%, L/Rch	1.0	1.4		Vrms
Output noise voltage	$V_{NO1}$	EXT MIC in, L/Rch, $R_g = 1\text{ k}\Omega$ , JIS-A		22	32	$\mu\text{Vrms}$
	$V_{NO2}$	INT MIC in, L/Rch, $R_g = 1\text{ k}\Omega$ , JIS-A Gain CTL Hi, Mi, Lo		16	24	$\mu\text{Vrms}$
Input switch crosstalk	$SW_{CR}$	INT MIC in $\rightarrow$ EXT MIC in ( $R_g = 1\text{ k}\Omega$ ) $f = 10\text{ kHz}$ , L/Rch		80	70	dB
Inter-channel crosstalk	$CH_{CR}$	INT/EXT MIC, Lch $\rightarrow$ Rch, Rch $\rightarrow$ Lch, $f = 10\text{ kHz}$		51	45	dB
Internal microphone power supply output voltage	$V_{INM}$	When pin 31 is DC, with $30\text{ k}\Omega$ load	2.65	2.8	2.95	V
External power supply output voltage	$V_{EXM}$	When connected to pin 16 (output current)	4.0	4.5		V
External power supply limiter current	$I_{LIM}$	When connected to pin 16 (output current)			30	mA
Input switching control voltage	$CTL_H$	High level, pin 29/pin 35 DC	1.3		$V_{CC}$	V
	$CTL_L$	Low level, pin 29/pin 35 DC	0		0.7	V
Input impedance	$Z_{IN}$	INT/EXT MIC in, L/Rch	60	75	90	$\text{k}\Omega$
Output impedance	$Z_O$	Pins 8 and 20		1	5	$\Omega$

### Block Diagram

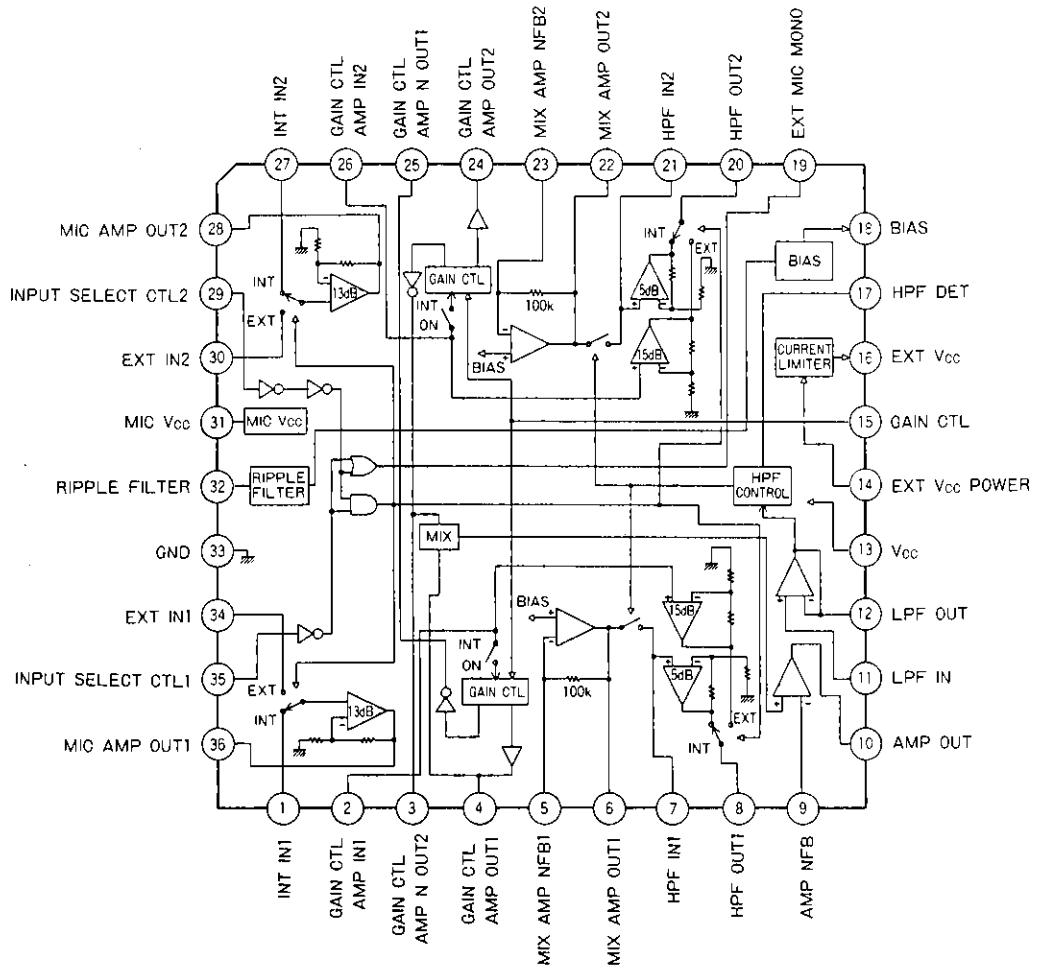

LA7471M

Test Circuit Diagram

Unit (Resistance: Ω, Capacitance: F)

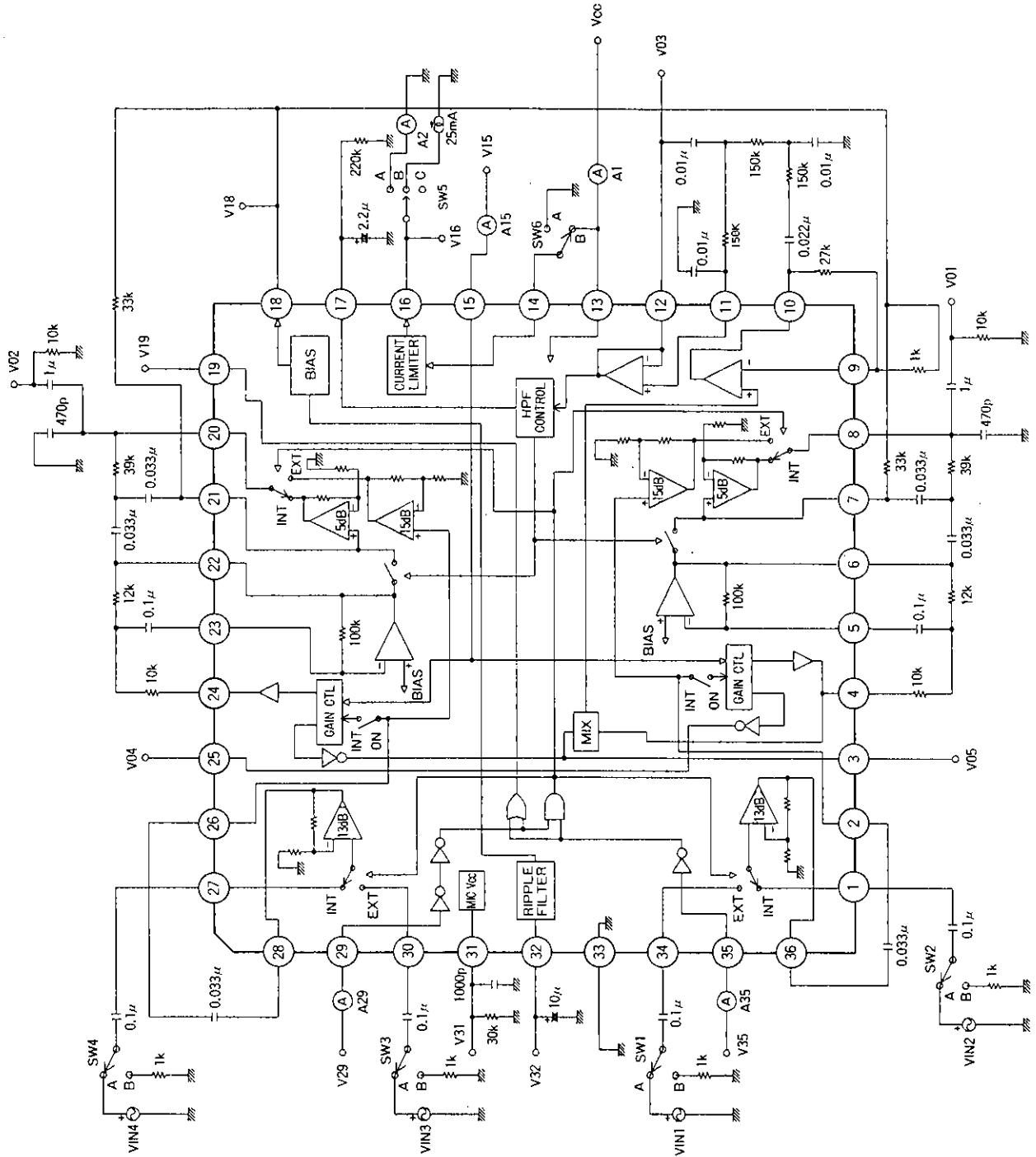

# LA7471M

## Application Circuit Diagram

Unit (Resistance:  $\Omega$ , Capacitance: F)

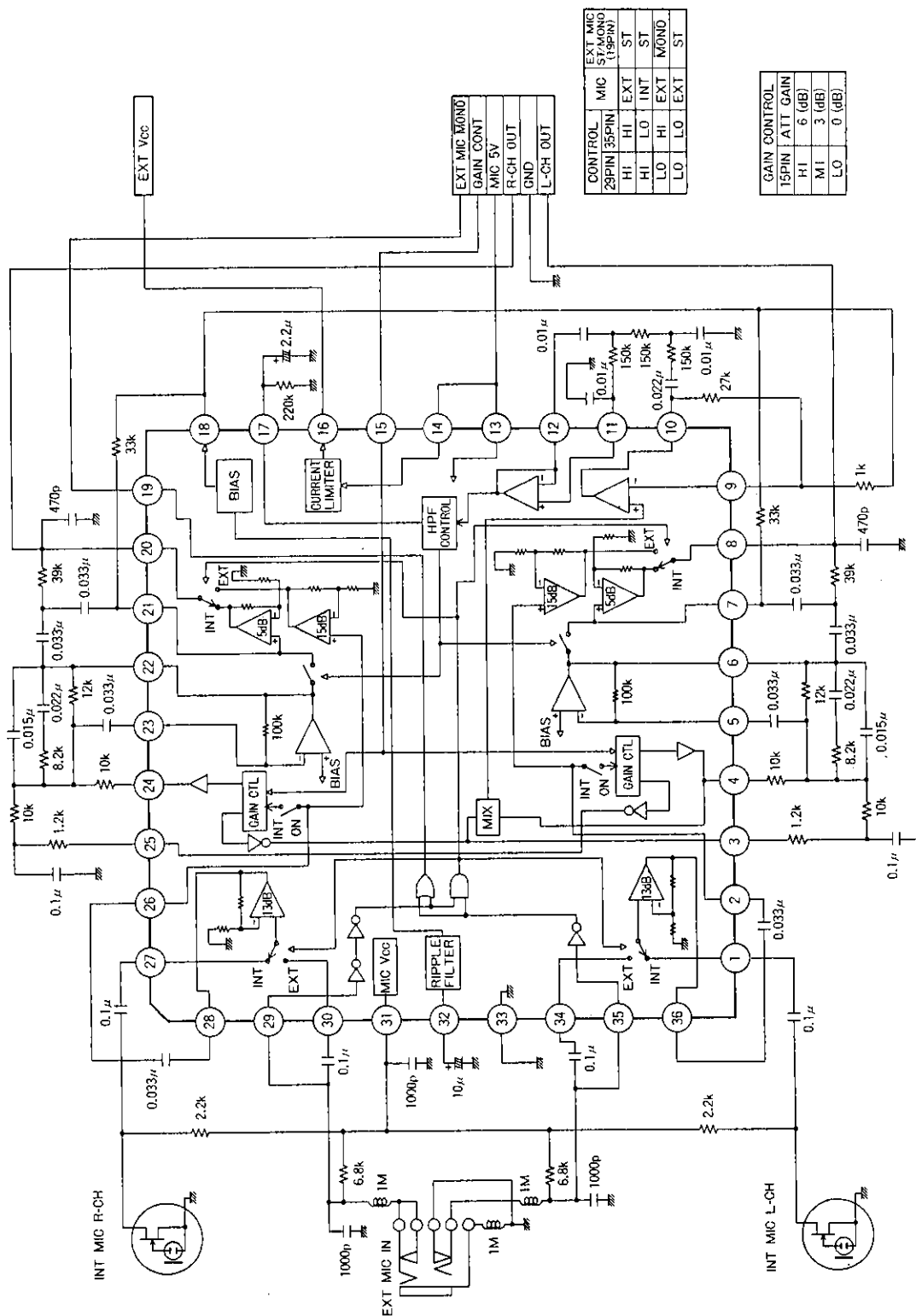

CONTROL	29PIN	MIC	EXT	MONO	EXT	MONO	ST
HI	HI	EXT	ST				
LO	LO	INT	ST				
LO	LO	EXT	MONO				
		LO	EXT	ST			

GAIN CONTROL	15PIN	ATT	GAIN
HI		6	(dB)
MI		3	(dB)
LO		0	(dB)

LA7471M

Switch Operation Table

Item	Symbol	SW1	SW2	SW3	SW4	SW5	SW6	V15	V29	V35	Test point
Current dissipation 1	I <sub>CC1</sub>	B	B	B	B	C	A	L	H	L	A <sub>1</sub>
Current dissipation 2	I <sub>CC2</sub>	B	B	B	B	C	B	L	H	L	A <sub>1</sub>
Voltage gain 1	VG <sub>1-1</sub>	A	B	B	B	C	A	L	L	L	V <sub>O1</sub>
	VG <sub>1-2</sub>	B	B	A	B	C	A	L	L	L	V <sub>O2</sub>
Voltage gain 2	VG <sub>2-1</sub>	B	A	B	B	C	A	H	H	L	V <sub>O1</sub>
	VG <sub>2-2</sub>	B	B	B	A	C	A	H	H	L	V <sub>O2</sub>
Voltage gain 3	VG <sub>3-1</sub>	B	A	B	B	C	A	M	H	L	V <sub>O1</sub>
	VG <sub>3-2</sub>	B	B	B	A	C	A	M	H	L	V <sub>O2</sub>
Voltage gain 4	VG <sub>4-1</sub>	B	A	B	B	C	A	L	H	L	V <sub>O1</sub>
	VG <sub>4-2</sub>	B	B	B	A	C	A	L	H	L	V <sub>O2</sub>
Total harmonic distortion	THD <sub>1-1</sub>	A	B	B	B	C	A	L	L	L	V <sub>O1</sub>
	THD <sub>1-2</sub>	B	B	A	B	C	A	L	L	L	V <sub>O2</sub>
	THD <sub>2-1</sub>	B	A	B	B	C	A	H	H	L	V <sub>O1</sub>
	THD <sub>2-2</sub>	B	B	B	A	C	A	H	H	L	V <sub>O2</sub>
	THD <sub>3-1</sub>	B	A	B	B	C	A	M	H	L	V <sub>O1</sub>
	THD <sub>3-2</sub>	B	B	B	A	C	A	M	H	L	V <sub>O2</sub>
	THD <sub>4-1</sub>	B	A	B	B	C	A	L	H	L	V <sub>O1</sub>
	THD <sub>4-2</sub>	B	B	B	A	C	A	L	H	L	V <sub>O2</sub>
Maximum output	V <sub>OM1-1</sub>	A	B	B	B	C	A	L	L	L	V <sub>O1</sub>
	V <sub>OM1-2</sub>	B	B	A	B	C	A	L	L	L	V <sub>O2</sub>
	V <sub>OM2-1</sub>	B	A	B	B	C	A	H	H	L	V <sub>O1</sub>
	V <sub>OM2-2</sub>	B	B	B	A	C	A	H	H	L	V <sub>O2</sub>
	V <sub>OM3-1</sub>	B	A	B	B	C	A	M	H	L	V <sub>O1</sub>
	V <sub>OM3-2</sub>	B	B	B	A	C	A	M	H	L	V <sub>O2</sub>
	V <sub>OM4-1</sub>	B	A	B	B	C	A	L	H	L	V <sub>O1</sub>
	V <sub>OM4-2</sub>	B	B	B	A	C	A	L	H	L	V <sub>O2</sub>
Output noise voltage 1	V <sub>NO1-1</sub>	B	B	B	B	C	A	L	L	L	V <sub>O1</sub>
	V <sub>NO1-2</sub>	B	B	B	B	C	A	L	L	L	V <sub>O2</sub>
Output noise voltage 2	V <sub>NO2-1</sub>	B	B	B	B	C	A	H	H	L	V <sub>O1</sub>
	V <sub>NO2-2</sub>	B	B	B	B	C	A	H	H	L	V <sub>O2</sub>
	V <sub>NO2-3</sub>	B	B	B	B	C	A	M	H	L	V <sub>O1</sub>
	V <sub>NO2-4</sub>	B	B	B	B	C	A	M	H	L	V <sub>O2</sub>
	V <sub>NO2-5</sub>	B	B	B	B	C	A	L	H	L	V <sub>O1</sub>
	V <sub>NO2-6</sub>	B	B	B	B	C	A	L	H	L	V <sub>O2</sub>
Input switch crosstalk	S <sub>CR1</sub>	B	A	B	B	C	A	L	L	L	V <sub>O1</sub>
	S <sub>CR2</sub>	B	B	B	A	C	A	L	L	L	V <sub>O2</sub>
Inter-channel crosstalk	C <sub>en1-1</sub>	A	B	B	B	C	A	L	L	L	V <sub>O2</sub>
	C <sub>en1-2</sub>	B	B	A	B	C	A	L	L	L	V <sub>O1</sub>
	C <sub>en2-1</sub>	B	A	B	B	C	A	H	H	L	V <sub>O2</sub>
	C <sub>en2-2</sub>	B	B	B	A	C	A	H	H	L	V <sub>O1</sub>
Internal microphone power supply output voltage	V <sub>INM</sub>	B	B	B	B	C	A	L	L	L	V <sub>31</sub>
External power supply output voltage	V <sub>EXM</sub>	B	B	B	B	B	B	L	L	L	V <sub>16</sub>
External power supply limiter current	I <sub>LIM</sub>	B	B	B	B	A	B	L	L	L	A <sub>2</sub>

## LA7471M

### Pin Functions

		Unit (resistance : $\Omega$ )			
Pin No.	Function	Internal Circuit	DC Voltage	Description	
1 27	INT in		2.1 V	Internal microphone input The input impedance is 75 k $\Omega$ .	
2 26	Gain CTL AMP in		2.1 V	Gain control amplifier input The input impedance is 100 k $\Omega$ .	
3 25	Gain CTL AMP N out		2.1 V	Gain control amplifier inverted output	
4 24	Gain CTL AMP out		2.1 V	Gain control amplifier output	
5 23	Mix AMP NFB		2.1 V	Mixer amplifier NFB pin	
6 22	Mix AMP out		2.1 V	Mixer amplifier output	
7 21	HPF in		2.1 V	High-pass filter amplifier input This is a high impedance input.	

LA7471M

Continued from preceding page.

Unit (resistance :  $\Omega$ )

Pin No.	Function	Internal Circuit	DC Voltage	Description
8 20	HPF out		2.1 V	Output for the high-pass filter 5 dB amplifier and the EXT mode 15 dB amplifier
9	AMP NFB		2.1 V	NFB for the amplifier that adjusts the wind noise exclusion high-pass filter on/off level
10	AMP out		2.1 V	Output for the amplifier that adjusts the wind noise exclusion high-pass filter on/off level. This is a low impedance output.
11	LPF in		2.1 V	Buffer input for forming a low-pass filter. The input impedance is 200 k $\Omega$ .
12	LPF out		2.1 V	Buffer output for forming a low-pass filter. This is a low impedance output.
13	V <sub>CC</sub>		V <sub>CC</sub>	Power supply for circuits other than the external V <sub>CC</sub> circuit
14	EXT V <sub>CC</sub> power			External V <sub>CC</sub> circuit power supply
15	Gain CTL			Gain control pin High level (4 V or higher): 6 dB Mid level (2 to 3 V): 3 dB Low level (1 V or lower): 0 dB

Continued on next page.

## LA7471M

Continued from preceding page.

Unit (resistance :  $\Omega$ )

Pin No.	Function	Internal Circuit	DC Voltage	Description
16	EXT V <sub>CC</sub>			External power supply with current limiter Capable of providing at least 4 V when an output current is 25 mA. When the output voltage is 0 V, the output current is less than 25 mA.
17	HPF DET			Detects the level used to turn the high-pass filter on and off.
18	BIAS		2.1 V	Reference voltage
19	EXT MIC mono			Outputs a low level only when the external microphone is monophonic.
28 36	Mic AMP out		2.1 V	Microphone amplifier output This is a low-impedance output.
29	Input select CTL2			Internal/external switch Control pin used to determine stereo or monophonic operation

Continued on next page.



## LA7471M

Continued from preceding page.

Unit (resistance :  $\Omega$ )

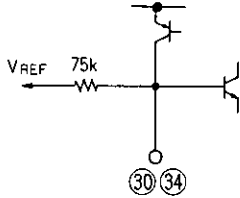
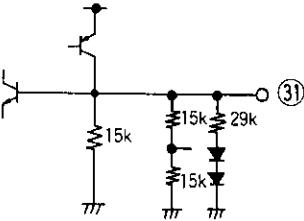
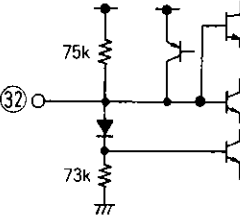
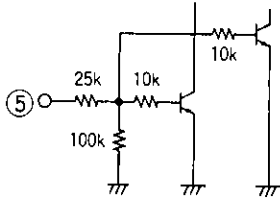
Pin No.	Function	Internal Circuit	DC Voltage	Description
30 34	EXT in		2.1 V	External microphone input The input impedance is 75 k $\Omega$ .
31	Mic V <sub>CC</sub>		2.8 V	Power supply for the internal microphone
32	Ripple filter		2.1 V	This pin is used to exclude ripple from internal circuits. Connect a capacitor and a resistor of 75 k $\Omega$ externally to exclude ripple.
33	GND		0	
35	Input select CTL1			Internal/external switch Control pin used to determine stereo or monophonic operation

No products described or contained herein are intended for use in surgical implants, life-support systems, aerospace equipment, nuclear power control systems, vehicles, disaster/crime-prevention equipment and the like, the failure of which may directly or indirectly cause injury, death or property loss.

Anyone purchasing any products described or contained herein for an above-mentioned use shall:

- ① Accept full responsibility and indemnify and defend SANYO ELECTRIC CO., LTD., its affiliates, subsidiaries and distributors and all their officers and employees, jointly and severally, against any and all claims and litigation and all damages, cost and expenses associated with such use;
- ② Not impose any responsibility for any fault or negligence which may be cited in any such claim or litigation on SANYO ELECTRIC CO., LTD., its affiliates, subsidiaries and distributors or any of their officers and employees jointly or severally.

Information (including circuit diagrams and circuit parameters) herein is for example only; it is not guaranteed for volume production. SANYO believes information herein is accurate and reliable, but no guarantees are made or implied regarding its use or any infringements of intellectual property rights or other rights of third parties.

This catalog provides information as of **April, 1996**. Specifications and information herein are subject to change without notice.