

Ordering number: EN 2739

<b>SANYO</b>	No.2739	Monolithic Linear IC
	<b>LA7545</b>	
VTR/TV IF Signal Processor (VIF + SIF)		

The LA7545 is an IC that contains the VIF section and SIF section in a 16-pin DIP. The small-sized package makes it possible to make LA7545-applied sets compact.

**Functions**

- VIF section
  - VIF amp, video detector, IF AGC, RF AGC, AFT, B/W noise canceler
- SIF section
  - Limiter amp, FM quadrature detector
- Muting
  - Audio muting (pin 2), audio-video simultaneous muting (pin 9), AFT defeat (pin 10)

**Features**

- Small-sized (16-pin DIP), multifunction
- Less buzz-beat level
- High-gain VIF amp
- High-speed AGC available

**Maximum Ratings at Ta = 25°C**

Maximum Supply Voltage	V <sub>CC</sub> max	14	V	unit
External Flow-out Current	I <sub>14</sub> max	6	mA	
Allowable Power Dissipation	P <sub>d</sub> max	1000	mW	Ta ≤ 56°C
Operating Temperature	T <sub>opr</sub>	-20 to +70	°C	
Storage Temperature	T <sub>stg</sub>	-55 to +125	°C	

**Operating Conditions at Ta = 25°C**

Recommended Supply Voltage	V <sub>CC</sub>	12	V	unit
Operating Voltage Range	V <sub>CC</sub> op	8.5 to 13.2	V	

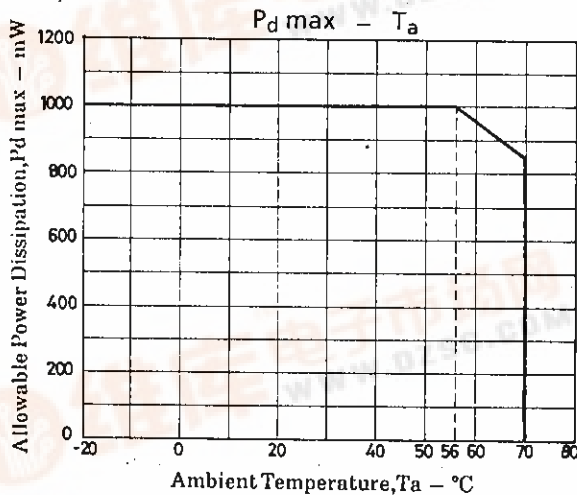

**Package Dimensions**

(unit: mm)

3006B

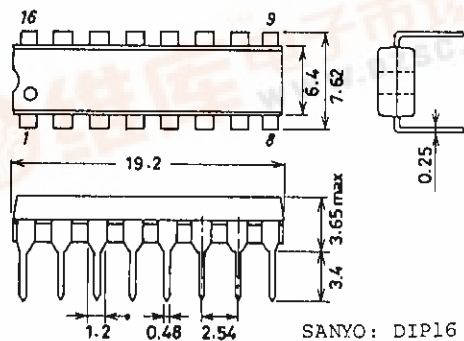

LA7545

Operating Characteristics at  $T_a = 25^\circ\text{C}$ ,  $V_{CC} = 12\text{V}$ ,  $f_p = 58.75\text{MHz}$ ,  $f_s = 54.25\text{MHz}$  (VIF),  
 $f_o = 4.5\text{MHz}$  (SIF)

			min	typ	max	unit
Circuit Current	$I_3$	DC	38	50	67	mA
Maximum RF AGC Voltage	$V_{15H}$	DC	10.5	11.0	11.4	V
Minimum RF AGC Voltage	$V_{15L}$	DC		0	0.5	V
Quiescent Video Output Voltage	$V_{14}$	DC	5.9	6.3	6.7	V
Quiescent AFT Output Voltage	$V_{11}$	DC	3.5	6.5	7.5	V
Input Sensitivity	$V_i$	$f_m = 400\text{Hz}$ , 40%AM, $V_o = 0.8\text{Vpp}$	38	44	50	dB $\mu$
AGC Range	GR	$f_m = 400\text{Hz}$ , 40%AM, $V_o = 0.8\text{Vpp}$	50	60		dB
Maximum Allowable Input	$V_{i\text{max}}$	$f_m = 15\text{kHz}$ , 78%AM, $V_o = \pm 1\text{dB}$	100	200		mVrms
Video Output Amplitude	$V_{o(\text{VIDEO})}$	$V_i = 10\text{mVrms}$ , $f_m = 15\text{kHz}$ , 78%AM	1.9	2.2	2.5	Vpp
Sync Signal Tip Level	$V_{14\text{tip}}$	$V_i = 10\text{mVrms}$ , CW	3.4	3.7	4.0	V
Output S/N	S/N	$V_i = 10\text{mVrms}$ , CW	46	52		dB
Maximum AFT Output Voltage	$V_{11H}$	$V_i = 10\text{mVrms}$ , SWEEP	11.0	11.5		V
Minimum AFT Output Voltage	$V_{11L}$	$V_i = 10\text{mVrms}$ , SWEEP		0.5	1.0	V
AFT Detection Sensitivity	Sf	$V_i = 10\text{mVrms}$ , SWEEP	50	80	120	mV/kHz
White Noise Threshold Level	$V_{\text{WTH}}$	$V_i = 10\text{mVrms}$ , SWEEP	6.5	6.9	7.3	V
White Noise Clamp Level	$V_{\text{WCL}}$	$V_i = 10\text{mVrms}$ , SWEEP	4.0	4.4	4.8	V
Black Noise Threshold Level	$V_{\text{BTH}}$	$V_i = 10\text{mVrms}$ , SWEEP	2.2	2.5	2.8	V
Black Noise Clamp Level	$V_{\text{BCL}}$	$V_i = 10\text{mVrms}$ , SWEEP	4.2	4.6	5.0	V
SIF Output Signal Voltage	$V_{o(\text{SIF})}$	P/S = 20dB	110	180	260	mVrms
Frequency Characteristic	$f_c$	-3dB	5	7		MHz
Differential Gain	DG	$V_i = 10\text{mVrms}$ , 87.5% VIDEO MOD		4		%
Differential Phase	DP	$V_i = 10\text{mVrms}$ , 87.5% VIDEO MOD		4		deg
VIF Input Resistance	VIF Ri			1.3		k $\Omega$
VIF Input Capacitance	VIF Ci			3.0		pF
SIF Limiting Voltage	$V_{i(\text{lim})}$	-3dB		250	500	$\mu\text{Vrms}$
FM Detection Output Voltage	$V_{o(\text{DET})}$	$V_i = 100\text{mVrms}$ , $f_m = 400\text{Hz}$ , $\Delta f = \pm 25\text{kHz}$	250	370	500	mVrms
FM Detection Output Distortion	THD <sub>(DET)</sub>	$V_i = 100\text{mVrms}$ , $f_m = 400\text{Hz}$ , $\Delta f = \pm 25\text{kHz}$		0.6	1.5	%
AM Rejection	AMR	$V_i = 31.6\text{mVrms}$ , $f_m = 400\text{Hz}$ , $\Delta f = \pm 25\text{kHz}$ , 30%AM	35	45		dB

# LA7545

## Sample Application Circuits

Unit (resistance:  $\Omega$ , capacitance: F)

JAPAN

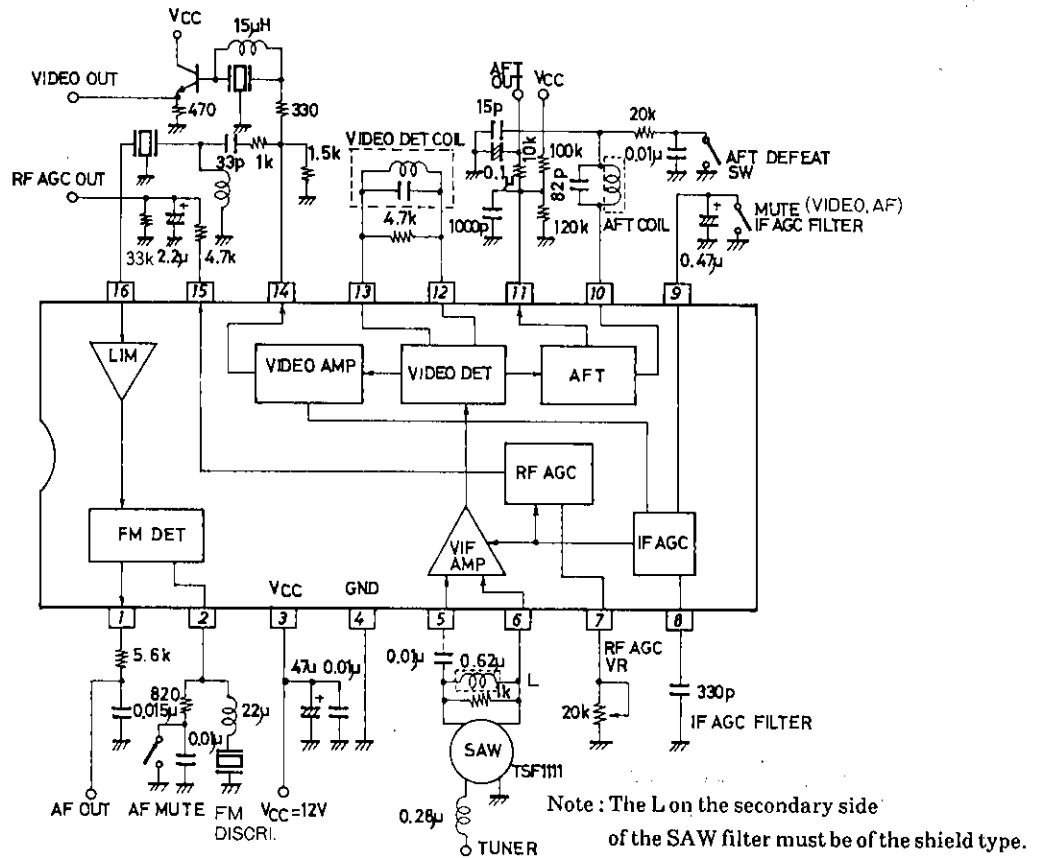

US

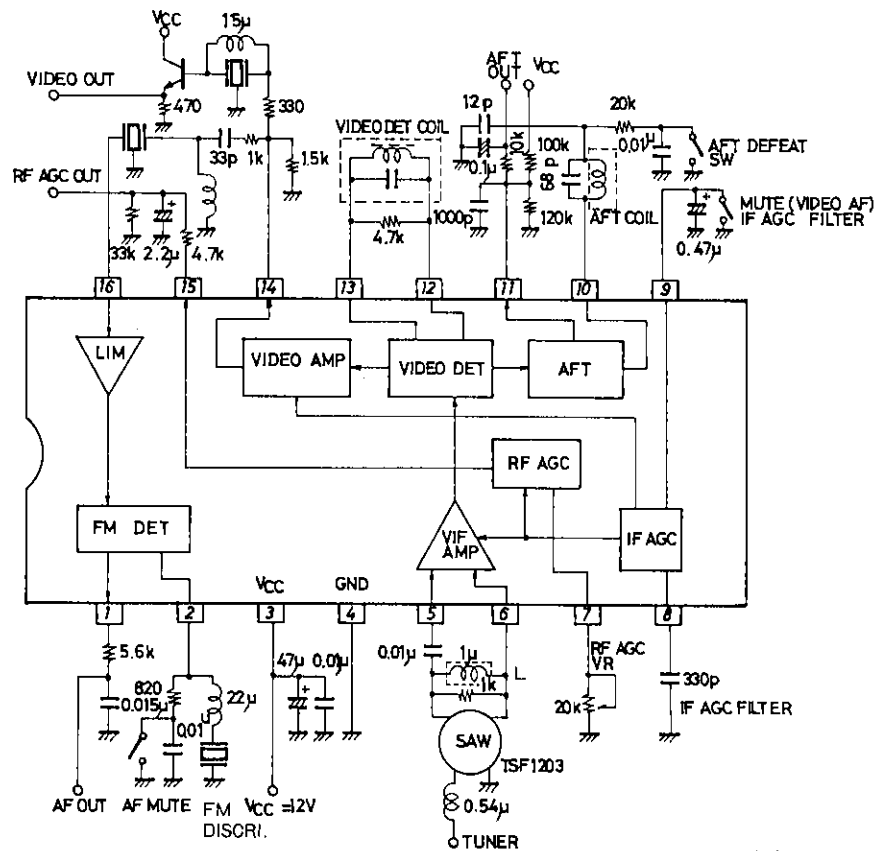

# LA7545

PAL

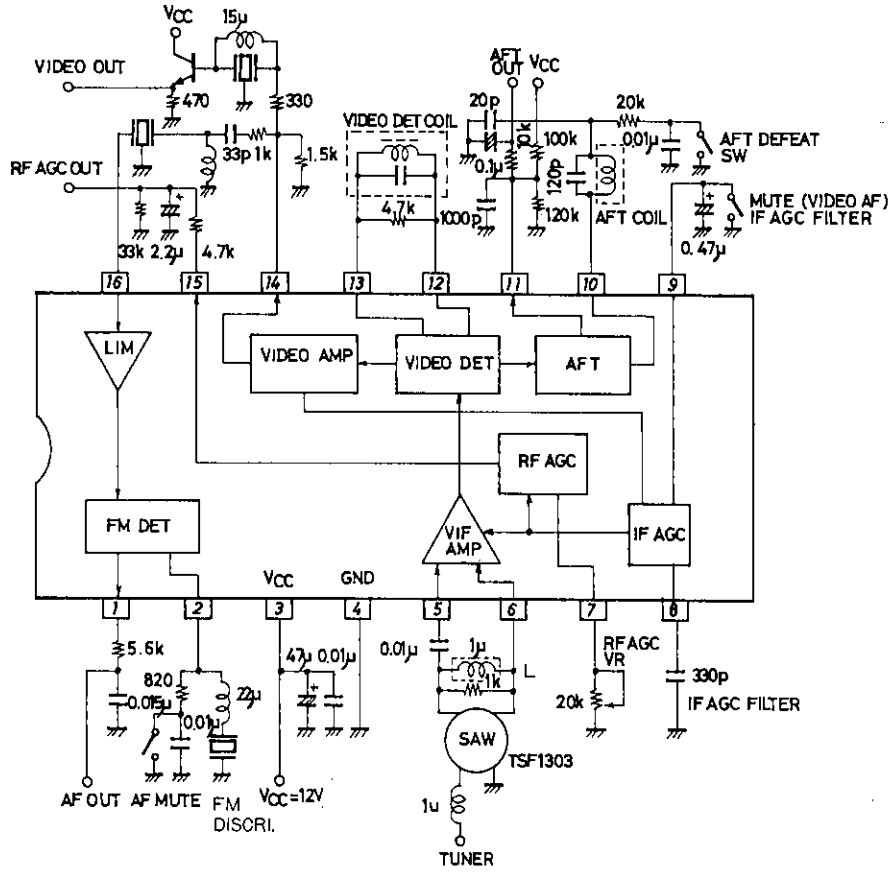

Unit (resistance:  $\Omega$ , capacitance: F)

	VIDEO DET	AFT Coil	FM DET Coil	FM DISCRI
JAPAN	<p>7mm-square 0.12<math>\varnothing</math> 5t Co = 39pF</p>	<p>7mm-square 0.2<math>\varnothing</math> 1 1/2t - 1 1/2t External C = 82pF RH</p>	<p>7mm-square 0.08<math>\varnothing</math> 19t - 19t Co = 100pF</p>	CDA4.5ME21 Murata Products
US	<p>7mm-square 0.1<math>\varnothing</math> 6t Co = 47pF</p>	<p>7mm-square 0.2<math>\varnothing</math> 2 1/2t - 2 1/2t External C = 68pF RH</p>	<p>7mm-square 0.08<math>\varnothing</math> 19t - 19t Co = 100pF</p>	CDA4.5ME21 Murata Products
PAL	<p>7mm-square 0.12<math>\varnothing</math> 7t Co = 33pF</p>	<p>7mm-square 0.2<math>\varnothing</math> 2 1/2t - 2 1/2t External C = 130pF RH</p>		CDA5.5ME21 Murata Products

# LA7545

## Proper Cares in Using the LA7545

Unit (resistance: Ω, capacitance: F)

Pin No.	Equivalent Circuit	Cares to be Taken in Applications
1		<p><b>Pin ①</b>... AF output</p> <ol style="list-style-type: none"> <li>(1) The quadrature detection output is output at pin ① through the emitter follower.</li> <li>(2) De-emphasis is provided externally as shown below.</li> </ol> <div style="text-align: right;"> </div>
2		<p><b>Pin ②</b>... FM detector</p> <ol style="list-style-type: none"> <li>(1) Phase shifter for quadrature detector</li> <li>(2) When a ceramic discriminator is used, the output level bandwidth depends on the damping resistor.</li> <li>(3) When muting is provided, DC-ground pin ② through the damping resistor.</li> </ol> <div style="display: flex; justify-content: space-around;"> <div style="text-align: center;"> </div> <div style="text-align: center;"> </div> </div>
3		<p><b>Pin ③</b>... Power supply</p> <ol style="list-style-type: none"> <li>(1) Connect the ceramic capacitor and chemical capacitor to GND near pin ③.</li> </ol>
4		<p><b>Pin ④</b>... GND</p> <ol style="list-style-type: none"> <li>(1) Connect GND of the IC and GND of the SAW with the distance between them as short as possible. Pass the connecting line through the center of the IC and surround the IC with GND.</li> </ol>
5 6		<p><b>Pin ⑤, ⑥</b>... VIF input</p> <ol style="list-style-type: none"> <li>(1) Input pins of VIF amp. Used with the input at pins ⑤, ⑥ balanced.</li> <li>(2) Use C3 for wiring of the input pins of the IC and cause a crossing on the printed circuit board. (Improvement in weak field characteristics)</li> </ol> <div style="text-align: center;"> <p style="text-align: right;">L : Shield type</p> </div>

Continued on next page.

LA7545

Continued from preceding page.

Unit (resistance:  $\Omega$ , capacitance: F)

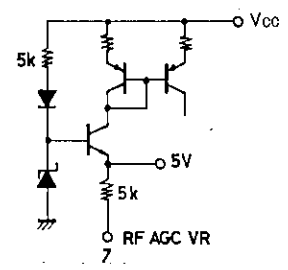
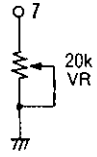
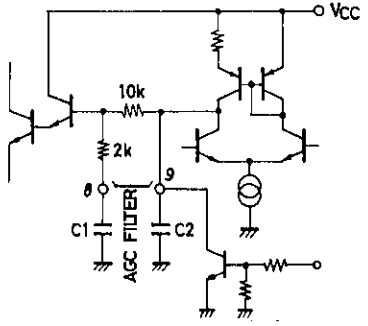
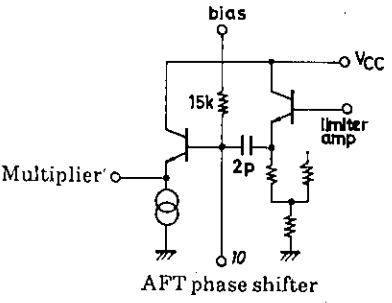
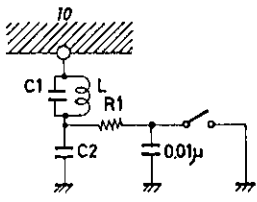
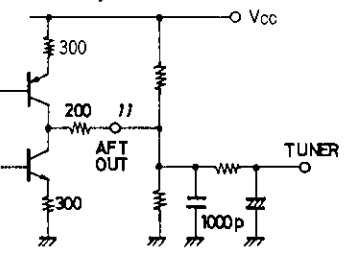
Pin No.	Equivalent Circuit	Cares to be Taken in Applications
7		<p>Pin ⑦... RF AGC VR</p> <p>(1) Use a VR of 20k<math>\Omega</math>.</p> 
8 9		<p>Pin ⑧,⑨... IF AGC filter</p> <p>(1) <math>C1 = 330\text{pF}</math>, <math>C2 = 0.47\mu\text{F}</math>            For <math>C2</math>, use a capacitor with good temperature characteristics.            (Example : OS capacitor, tantalum electrolytic capacitor)            To make the AGC speed higher, use the following constants.  <math>C1 = 0.47\mu\text{F}</math>, <math>C2 = 0.068\mu\text{F}</math>            For <math>C2</math>, use a polyester film capacitor.</p> <p>(2) When providing audio-video simultaneous muting, connect pin 9 to GND through a transistor as shown left.</p>
10		<p>Pin ⑩ ... AFT coil</p> <p>(1) The AFT slope becomes steeper and the bandwidth becomes narrower with increasing <math>C1</math>. A recommended value of <math>C1</math> is approximately 100pF.</p> <p>(2) The AFT slope becomes steeper with increasing <math>Q</math>. A recommended value of <math>Q</math> is approximately 100.</p> <p><math>C2</math> provides a sound trap to prevent malfunction. Normally, <math>C1:C2 = 5:1</math> is selected. <math>R1</math> is used to DC-ground pin 10 with an AFT defeat SW. The value of <math>R1</math> must not exceed 20k<math>\Omega</math>. When no defeat is provided, <math>R1</math> is not required.</p> 
11		<p>Pin ⑪ ... AFT output</p> <p>(1) Open collector type to which a load resistor is connected externally. The DC potential depends on the resistance ratio and the AFT sensitivity depends on the parallel resistor value. The slope becomes steeper with increasing resistor value. It is recommended to use with 200k<math>\Omega</math>//200k<math>\Omega</math> or less. (100k<math>\Omega</math>//120k<math>\Omega</math> recommended)</p>

Continued on next page.

Continued from preceding page.

Unit (resistance:  $\Omega$ , capacitance: F)

Pin No.	Equivalent Circuit	Cares to be Taken in Applications
12 13		<p>Pin ⑫, ⑬ ... Video det. coil</p> <p>(1) Q of coil is approximately 60. When the value of the damping resistor is increased, the 920kHz beat characteristic is improved, but the disturbance of video output occurs earlier at the detuning mode. A recommended value of the damping resistor is 3 to 7.5k<math>\Omega</math>.</p>
14		<p>Pin ⑭ ... Video output</p> <p>(1) Emitter follower output. When pin ⑭ is connected to GND through a resistor, the emitter current increases and the output impedance decreases. The 920kHz beat characteristic is improved with decreasing resistor value. However, the resistor value must be kept at 1k<math>\Omega</math> and must not be less than 1k<math>\Omega</math>.</p> <p style="text-align: center;"><math>V_{CC}=12V \dots 1.5k\Omega</math> <math>V_{CC}=9V \dots 1k\Omega</math></p>
15		<p>Pin ⑮ ... RF AGC output</p> <p>(1) Emitter follower output to which R,C are connected externally to provide a time constant. The maximum output voltage at <math>V_{CC}=12V</math> is 8V. If a voltage less than 8V is required, use bleeder resistors.</p>
16		<p>Pin ⑯ ... SIF input</p> <p>(1) The input impedance is approximately 1k<math>\Omega</math>. The signal is applied from pin ⑭ to pin ⑯ through H.P.F. and ceramic B.P.F. There are various types of H.P.F. as shown below. The steeper the H.P.F. slope becomes, the more the buzz characteristic is improved. In particular, when the P/S is made deep, the 1/2IF (NTSC 2.25MHz, video modulation) buzz characteristic is improved.</p> <div style="display: flex; flex-direction: column; align-items: center;"> <ol style="list-style-type: none"> <li>1) </li> <li>2) </li> <li>3) </li> <li>4) </li> </ol> </div>

# LA7545

## Description of LA7545 Operation (Outline)

### 1. IF amp (Intermediate frequency amplifier)

As shown in Fig.1-1, the IF amp consists of three amplifiers directly connected with balanced input. Amps 1,2,3 and the gain are controlled by the AGC (Automatic Gain Control).

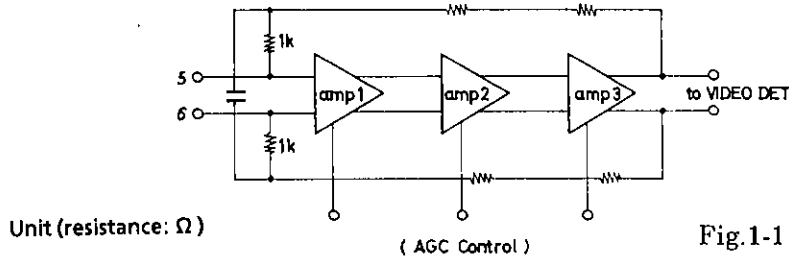

Fig.1-1

### 2. Video detector

As shown in Fig.2-1, the video detector is of pseudo sync detection type. Detection is performed by multiplying the IF signal by the switching signal passed through the limiter amp.

Since the signal level of the tank circuit is relatively low, spurious radiation causes less problem.

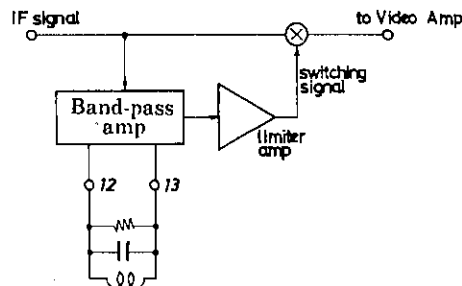

Fig.2-1

### 3. Video amp B/W noise inverter

As shown in Fig.3-1, the video amp amplifies the detection output voltage to a desired voltage ( $\approx 2.2V_{p-p}$ ) over a wide band range. The amplified video signal passes through the B/W noise inverter and is output at pin 14.

**White noise inverter :** When a noise whose level exceeds the white level of the video signal as shown in Fig.3-2 arises, the noise is noticeable on the screen and the noise inverter operates as shown in Fig.3-3.

**Black noise inverter :** When a noise whose level exceeds the sync signal tip as shown in Fig.3-2 arises, the noise inverter operates as shown in Fig.3-3 so that the sync separation circuit at the next stage is hard to malfunction.

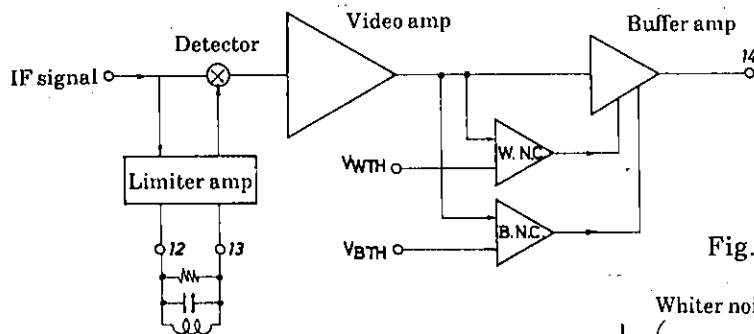

Fig.3-1

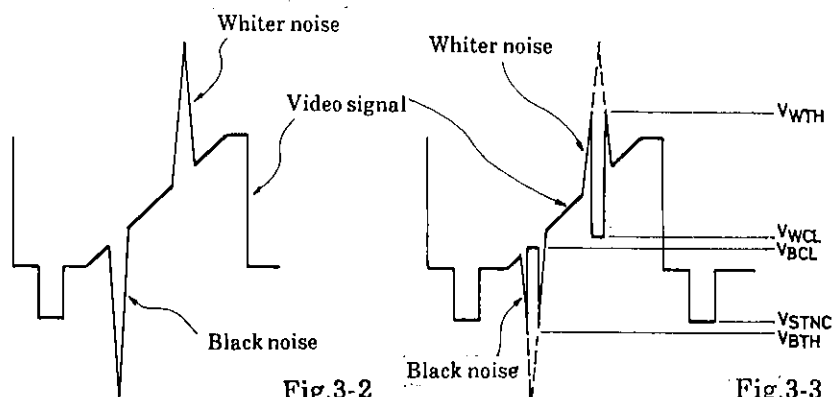

Fig.3-2

Fig.3-3



## LA7545

### 4. AGC detector

As shown in Fig.4-1, the AGC detector is a peak AGC detector equipped with a noise canceler function which prevents malfunction of the AGC system. The AGC detection output (pin 9) is also used for the video output, FM detection output, simultaneous muting.

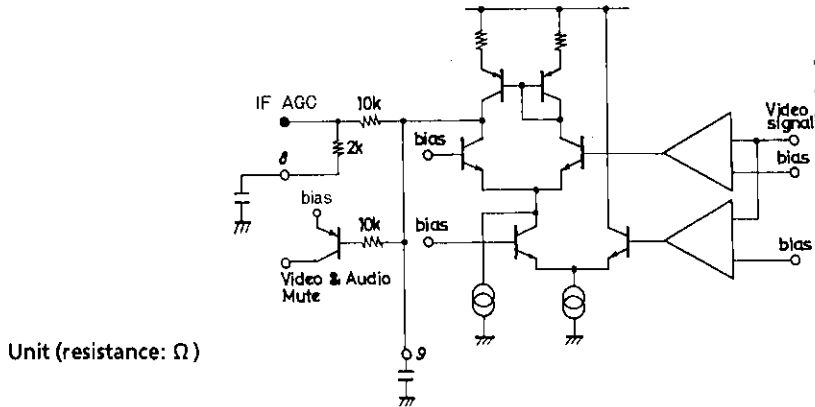

Fig.4-1

### 5. RF AGC

As shown in Fig.5-1, the RF AGC controls the gain of the tuner's RF amp. Measurement is made whether the region is a snow region (noise on the screen, poor S/N ratio) or a saturation region (contours can be clearly seen but look bad due to video signal distortion), and the RF AGC delay point is set as shown in Fig.5-2.

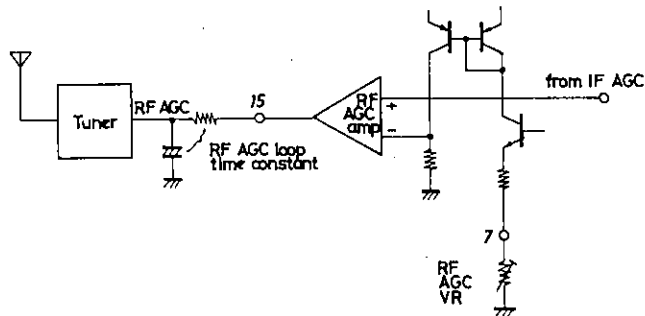

Fig.5-1

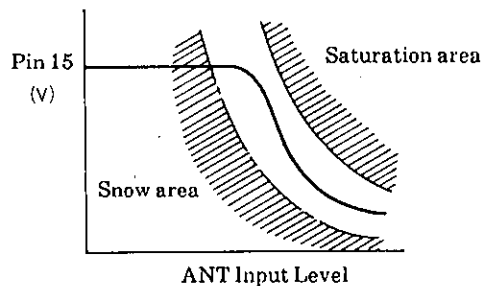

Fig.5-2

6. AFT (Automatic fine tuning)

As shown in Fig.6-1, the AFT is a balanced type using a quadrature detection circuit. The input signal is shifted 90° by the internal capacitor and external phase shifter, and quadrature-detected. Pin 10 is also used as the AFT defeat pin.

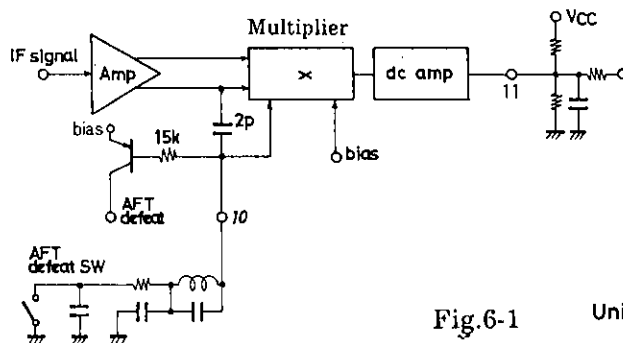

Fig.6-1 Unit (resistance: Ω, capacitance: F)

7. SIF limiting amp

As shown in Fig.7-1, the SIF limiting amp is an unbalanced limiting amp consisting of four stages directly connected. There is negative feedback within the IC to balance the differential amplifier.

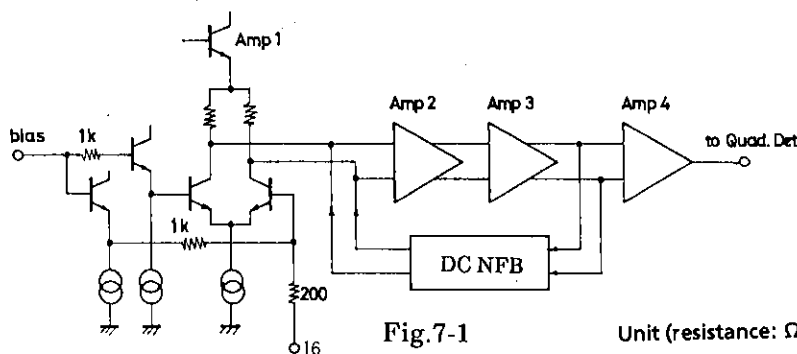

Fig.7-1 Unit (resistance: Ω)

8. Quadrature detection

SIF quadrature detection is performed by the single-pin detector with internal phase shift capacitor, as shown in Fig.8-1. FM detection is performed by shifting the SIF signal 90° and multiplying it. The characteristics of the phase shifting circuit are as follows:

1. Demodulation output ..... Mainly  $Q_L$
  2. Distortion ..... Linearity of phase shifting circuit, symmetry of S curve
- ◎ The linearity of the phase shifting circuit can be improved by lowering  $Q_L$  and increasing the band with a single-tuned circuit, but the FM detection output will drop.
  - ◎ Pin 2 is also used as the SIF muting pin.

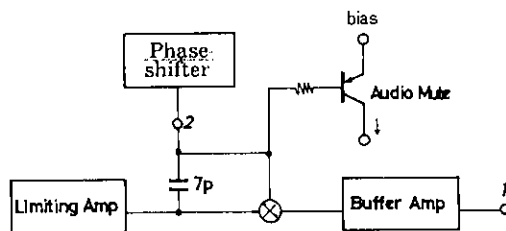

Fig.8-1

- No products described or contained herein are intended for use in surgical implants, life-support systems, aerospace equipment, nuclear power control systems, vehicles, disaster/crime-prevention equipment and the like, the failure of which may directly or indirectly cause injury, death or property loss.
- Anyone purchasing any products described or contained herein for an above-mentioned use shall:
  - ① Accept full responsibility and indemnify and defend SANYO ELECTRIC CO., LTD., its affiliates, subsidiaries and distributors and all their officers and employees, jointly and severally, against any and all claims and litigation and all damages, cost and expenses associated with such use:
  - ② Not impose any responsibility for any fault or negligence which may be cited in any such claim or litigation on SANYO ELECTRIC CO., LTD., its affiliates, subsidiaries and distributors or any of their officers and employees jointly or severally.
- Information (including circuit diagrams and circuit parameters) herein is for example only; it is not guaranteed for volume production. SANYO believes information herein is accurate and reliable, but no guarantees are made or implied regarding its use or any infringements of intellectual property rights or other rights of third parties.