

<b>SANYO</b>	No.4616	Monolithic Linear IC
		<b>LA7945N</b>
<b>Closed Caption Signal (US specifications) Extraction IC</b>		

### Overview

The LA7945N extracts the closed caption signal overlapped in the video signal vertical retrace period and transfers the data and clock signal to a decoder IC. This IC requires the use of either an add-on type decoder, such as the LC7458B or 7457A (for I<sup>2</sup>C), or a microcontroller type decoder, such as the LC8640XX.

### Functions

- Synchronization separation
- VCO
- Vertical countdown
- Horizontal countdown
- Data slicing
- Dual loop AFC
- Field discrimination
- Lock detection
- Vertical/horizontal pulse output

### Features

- Adoption of a dual loop AFC allows the LA7945N to stably extract the caption signal.
- Provides the pulse outputs required by caption decoder ICs.

### Specifications

#### Maximum Ratings at Ta = 25°C

Parameter	Symbol	Condition	Rating	Unit
Maximum power supply voltage	V <sub>CC</sub> max		7	V
Allowable power dissipation	P <sub>d</sub> max	Ta ≤ 70°C	250	mW
Operating temperature	T <sub>opr</sub>		-10 to +70	°C
Storage temperature	T <sub>stg</sub>		-55 to +150	°C

#### Operating Conditions at Ta = 25°C

Parameter	Symbol	Rating	Unit
Recommended power supply voltage	V <sub>CC</sub>	5	V
Operating power supply voltage range	V <sub>CC</sub> op	4.5 to 5.5	V

### Package Dimensions

unit: mm

#### 3059-DIP22S

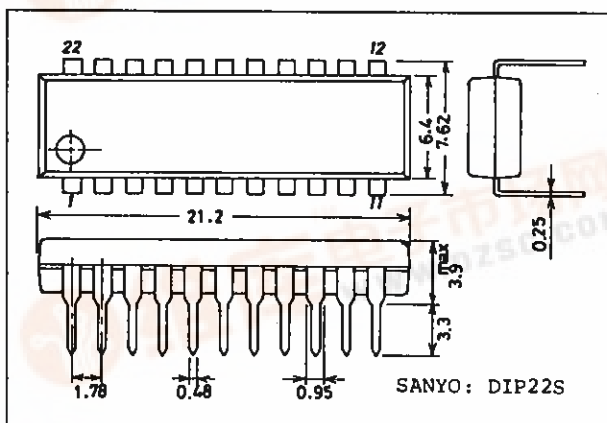

LA7945N

Electrical and Operating Characteristics at Ta = 25°C, V<sub>CC</sub> = 5.0 V, Input signal: sync-white 1.0 V

Parameter	Symbol	Rating			Unit	
		min	typ	max		
Horizontal pull-in range	f <sub>HPULL</sub>	±1.5			kHz	
Horizontal free-running frequency	f <sub>HFREE</sub>	15.3	15.7	16.3	kHz	
Input clamping voltage	V <sub>CLMP</sub>	2.3	2.5	2.7	V	
H LOCK filter threshold level	V <sub>LOCKTH</sub>	2.3	2.5	2.7	V	
Synchronization separation output	High level	V <sub>SYNCH</sub>	4.0	4.2	5.0	V
	Low level	V <sub>SYNCL</sub>	0	0.8	1.0	V
H LOCK filter	High level	V <sub>LOCKH</sub>	4.0	4.2	5.0	V
	Low level	V <sub>LOCKL</sub>	0	0.8	1.0	V
Data output	High level	V <sub>DATAH</sub>	4.0	4.2	5.0	V
	Low level	V <sub>DATAL</sub>	0	0.8	1.0	V
Clock output	High level	V <sub>CLKH</sub>	4.0	4.2	5.0	V
	Low level	V <sub>CLKL</sub>	0	0.8	1.0	V
21H output	High level	V <sub>21HH</sub>	4.0	4.2	5.0	V
	Low level	V <sub>21HL</sub>	0	0.8	1.0	V
	Pulse width	V <sub>21HW</sub>	60	65	70	μs
O/E output	High level	V <sub>OEH</sub>	4.0	4.2	5.0	V
	Low level	V <sub>OEL</sub>	0	0.8	1.0	V
	Pulse width	V <sub>OEW</sub>	16.4	16.7	17.0	ms
Horizontal pulse output	High level	V <sub>HSH</sub>	4.0	4.2	5.0	V
	Low level	V <sub>HSL</sub>	0	0.8	1.0	V
	Pulse width	V <sub>HSW</sub>	7.4	7.7	8.0	μs
Vertical pulse output	High level	V <sub>RSTH</sub>	4.0	4.2	5.0	V
	Low level	V <sub>RSTL</sub>	0	0.8	1.0	V
	Pulse width	V <sub>RSTW</sub>	30.8	31.8	32.8	μs
Input signal level	V <sub>IN</sub>	-6	0	+3	dB	
CLK-RUN-IN start time	T <sub>ST</sub>	6.6	7.6	8.6	μs	
Current dissipation	ICC	14.0	18.0	22.0	mA	

Note: Must not be pulled in to any frequency other than f<sub>H</sub>.  
 The pin 11 capacitor should be 100 pF ±5%.  
 The pin 12 resistor should be 15 kΩ ±1%.

## LA7945N

### Test Conditions

Parameter	Symbol	Test point	Test method
Horizontal pull-in range	$f_{HPULL}$	Pins 2 and 10	Vary the frequency $f_H$ of the input signal and measure the point where the phase of pins 2 and 10 locks using an oscilloscope.
Horizontal free-running frequency	$f_{HFREE}$	Pin 10	Use a frequency counter to measure the frequency when there is no signal.
Input clamping voltage	$V_{CLMP}$	Pin 17	Measure the pedestal level with an oscilloscope.
H LOCK filter threshold level	$V_{LOCKTH}$	Pin 7	Measure the voltage at which pin 7 goes high by applying a DC voltage to pin 8 and varying that voltage.
Synchronization separation output	High level $V_{SYNCH}$	Pin 2*1	Measure the pin 2 high and low levels with an oscilloscope.
	Low level $V_{SYNCL}$		
H LOCK filter	High level $V_{LOCKH}$	Pin 7*1	Measure the pin 7 high and low levels with an oscilloscope.
	Low level $V_{LOCKL}$		
Data output	High level $V_{DATAH}$	Pin 3*1,2	Measure the pin 3 high and low levels with an oscilloscope.
	Low level $V_{DATA L}$		
Clock output	High level $V_{CLKH}$	Pin 5*1,2	Measure the pin 5 high and low levels with an oscilloscope.
	Low level $V_{CLKL}$		
21H output	High level $V_{21HH}$	Pin 1*1	Measure the pin 1 high and low levels and the length of the high level period with an oscilloscope.
	Low level $V_{21HL}$		
	Pulse width $V_{21HW}$		
O/E output	High level $V_{OE H}$	Pin 6*1	Measure the pin 6 high and low levels and the length of the high level period with an oscilloscope.
	Low level $V_{OE L}$		
	Pulse width $V_{OE W}$		
Horizontal pulse output	High level $V_{HEH}$	Pin 10*1	Measure the pin 10 high and low levels and the length of the high level period with an oscilloscope.
	Low level $V_{HSL}$		
	Pulse width $V_{HSW}$		
Vertical pulse output	High level $V_{RSTH}$	Pin 9*1	Measure the pin 9 high and low levels and the length of the high level period with an oscilloscope.
	Low level $V_{RSTL}$		
	Pulse width $V_{RSTW}$		
Input signal level	$V_{IN}$	Each of pins 1, 3, 5, and 6*2	Vary the signal level input to pin 17, and confirm that the pin 1, 3, 5, and 6 outputs are operating correctly.
CLK-RUN-IN start time	TST	Each of pins 1, 3, 5, and 6*2,3	Vary the time between SYNC and CLK-RUN-IN, and confirm that the pin 1, 3, 5, and 6 outputs are operating correctly.
Current dissipation	ICC	Pin 16*2	Connect a current meter to pin 16, and measure the current during decoding.

- Notes: 1. Connect a 20 k $\Omega$  resistor between the pin being measured and  $V_{CC}$ , and also connect a 20 k $\Omega$  from that measurement pin to GND.  
 2. During measurement, this pin carries the closed caption encoded signal.  
 3. Time TST is shown in the figure below.

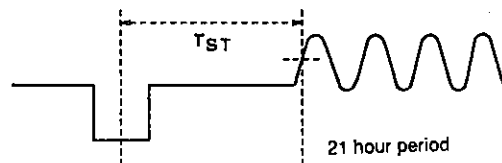



Pin Descriptions

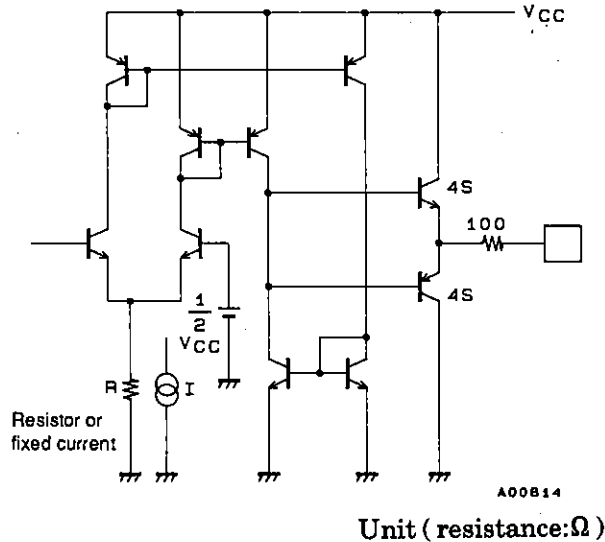

Figure 1

- The peripheral circuit for the pins described below is shown in figure 1. Either a resistor or a fixed current supply is connected to the lower side (the side away from the pin) of the differential amplifier.
- Pin 1 (21H OUT):  $R = 18\text{ k}\Omega$ . This signal goes high during the 21H and 284H periods. The fall of this signal is taken as the completion of data transfer.
- Pin 2 (sync SEP):  $R = 9\text{ k}\Omega$ . Synchronization separation output, see pin 19.
- Pin 3 (DATA OUT):  $I = 280\text{ }\mu\text{A}$ . Outputs the data overlapped with the vertical retrace period.
- Pin 5 (CLOCK OUT):  $R = 9\text{ k}\Omega$ . A clock output whose phase matches that of DATA OUT.
- Pin 6 (O/E OUT):  $R = 18\text{ k}\Omega$ . Field discrimination signal. High on odd fields.
- Pin 7 (H LOCK OUT):  $I = 50\text{ }\mu\text{A}$ . A resistor and capacitor are connected to pin 8, and this pin goes high when the internal VCO and the input signal are synchronized.
- Pin 9 (V PULSE OUT):  $R = 18\text{ k}\Omega$ . Set low during the 0.5H period synchronized with the vertical synchronization signal.
- Pin 10 (H PULSE OUT):  $R = 18\text{ k}\Omega$ . Outputs a low signal synchronized with the horizontal synchronization signal.

- Pin 8 (H LOCK FILTER): The H LOCK detection filter is connected to this pin.

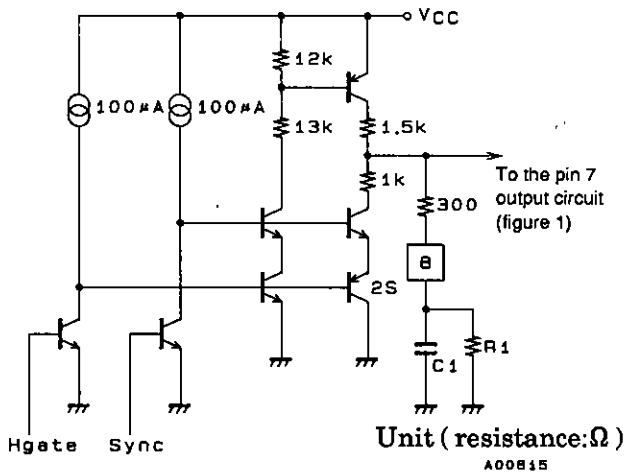

Figure 2: Pin 8 (H LOCK FILTER) Peripheral Circuit

Pin 8 is charged when the H gate and Sync phases match, and this voltage is compared and output to pin 7. The resistor R1 is used for discharge. The time from internal VCO locking until pin 7 goes high, and the time from lock release to the pin going low can be adjusted by changing the values of C1 and R1. If the pin 7 H LOCK OUT output is not used, C1 and R1 will be unnecessary.

- Pin 11 (VCO C): The capacitor for the  $32\text{f}_H$  VCO is connected to this pin. (Error: 5%)

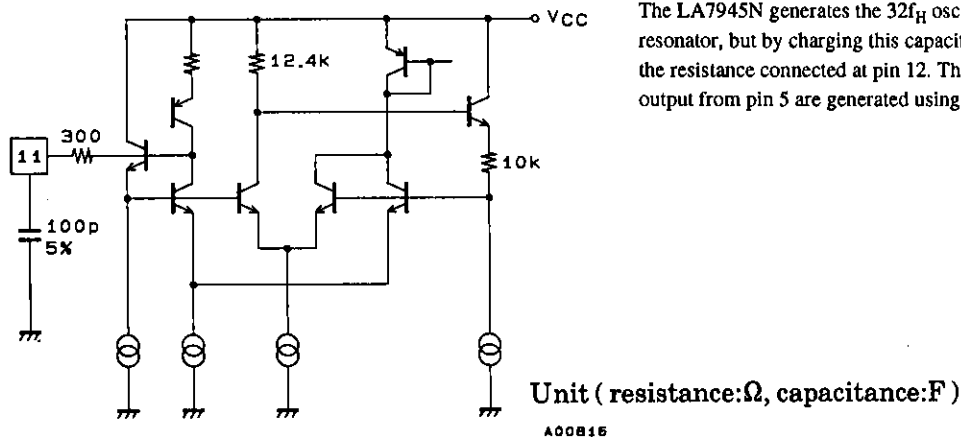

Figure 3: Pin 11 (VCO C) Peripheral Circuit

The LA7945N generates the  $32\text{f}_H$  oscillation not by using a ceramic resonator, but by charging this capacitor with the fixed current defined by the resistance connected at pin 12. The horizontal pulses and the clock output from pin 5 are generated using this oscillator as a reference.

## LA7945N

- Pin 12 (VCO R): The resistor for the  $32f_H$  VCO is connected to this pin. (Error: 1%)

This resistor defines the current that charges the pin 11 capacitor. A DC voltage of  $2/3$  that of  $V_{CC}$  is output from pin 12.

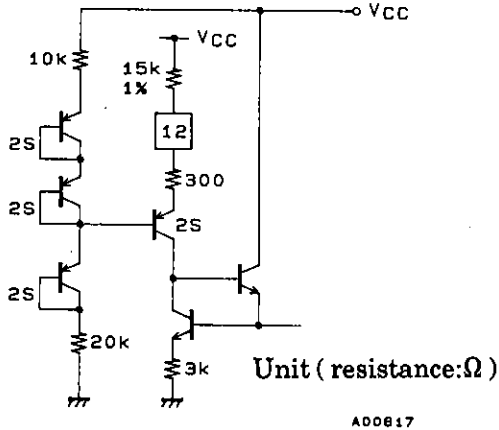

**Figure 4: Pin 12 (VCO R) Peripheral Circuit**

- Pin 13 (AFC1): The horizontal AFC filter is connected to this pin.

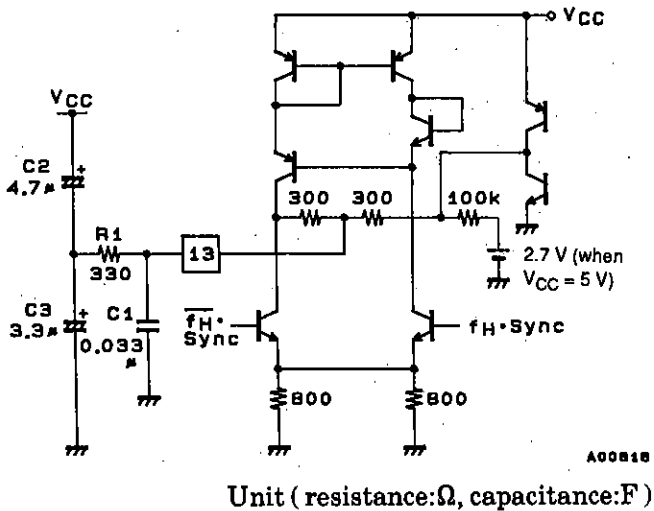

Unit (resistance:Ω, capacitance:F)

**Figure 5: Pin 13 (AFC1) Peripheral Circuit**

Although the ability to follow horizontal fluctuations improves as  $R_1$  increases, the holding power is reduced. Select this value according to the application circuit. Since the closed caption signal is overlapped with 21H, the VCO in this IC is influenced by signals such as the vertical synchronization signal and the copy guard signal. The values of  $C_2$  and  $C_3$  should be determined so that the VCO is stable with respect to these signals. To stabilize pin 13 at a voltage of about 2.7 V (when  $V_{CC} = 5$  V) with no input, the ratio of  $C_2$  and  $C_3$  should be set so that this voltage takes on a value close to that of pin 13 when power is first applied.

## LA7945N

- Pin 14 (AFC2): Used for phase adjustment of the internal VCO CLOCK and CLK-RUN-IN.

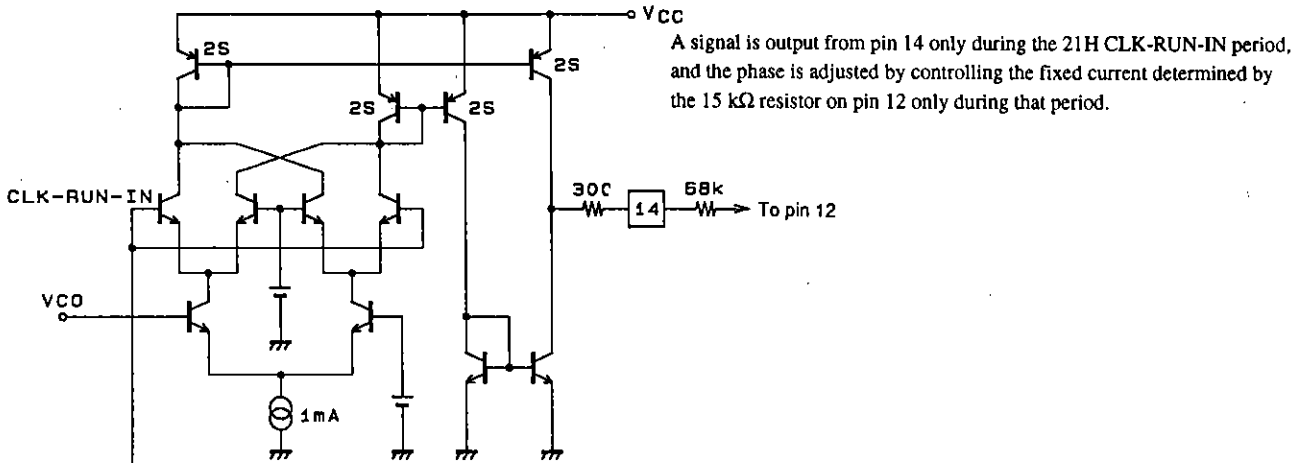

- Pin 15 (CLOCK PHASE): CLOCK-RUN-IN phase compensation pin.

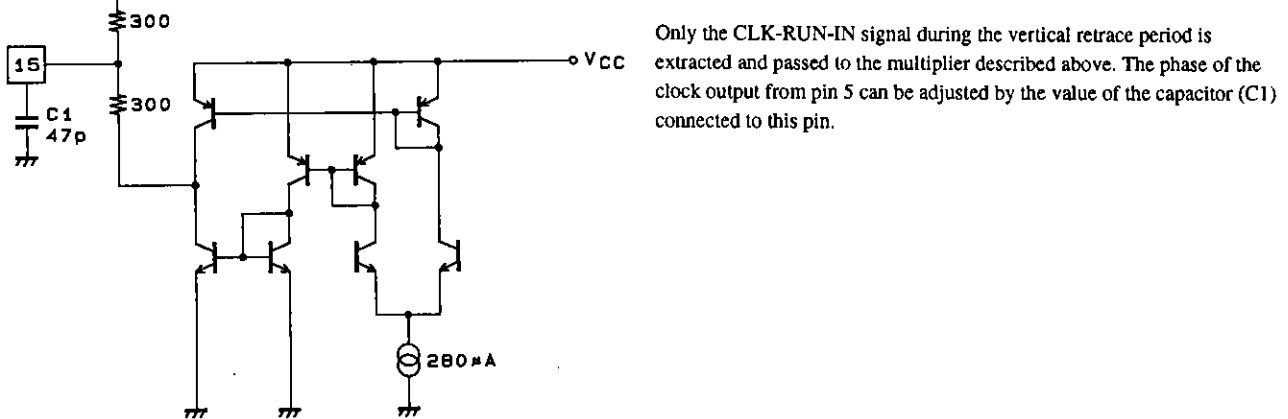

Unit ( resistance:Ω, capacitance:F) A00870

**Figure 6: Pin 14 (AFC2) and Pin 15 (CLOCK PHASE) Peripheral Circuits**

- Pin 17 (VIDEO IN): The video input pin. (sync-white 1 Vp-p)

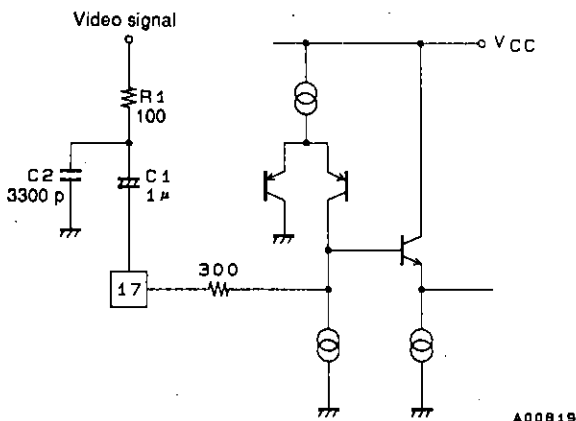

Unit ( resistance:Ω, capacitance:F) A00819

**Figure 7: Pin 17 (VIDEO IN) Peripheral Circuit**

## LA7945N

- Pin 18 (DATA LPF): The data slice LPF is connected to this pin.

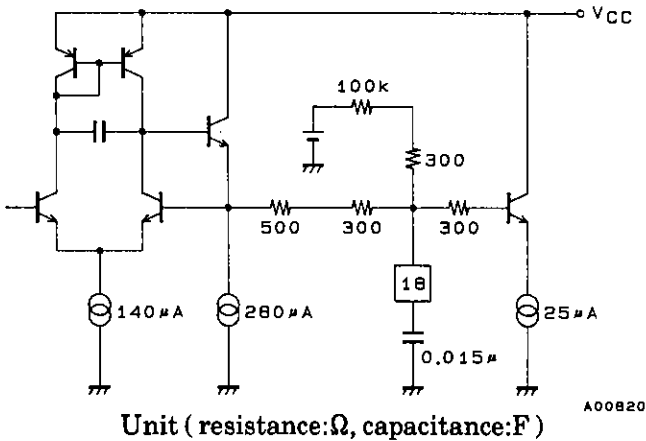

A signal is output from pin 18 during the vertical retrace period CLK-RUN-IN period, and an LPF, which is used to detect the average value of CLK-RUN-IN (to be used as the slice level), is connected to this pin.

**Figure 8: Pin 18 (DATA LPF) Peripheral Circuit**

- Pin 19 (PEAK HOLD): The synchronization separator peak hold capacitor is connected to this pin.

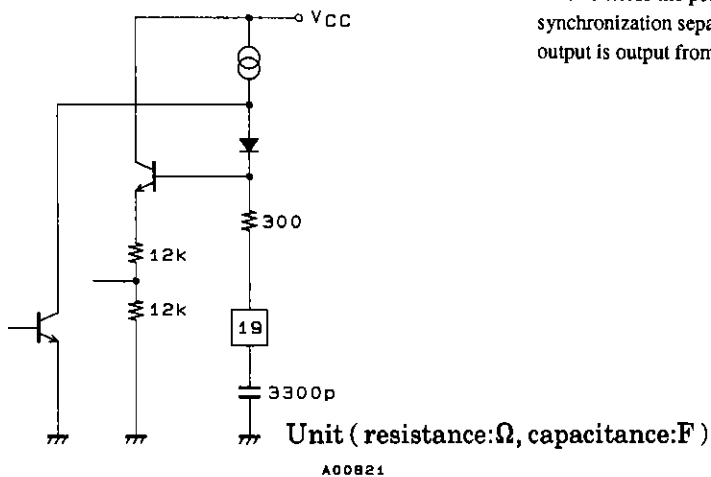

This IC holds the peak value of sync on pin 19, and performs synchronization separation using 1/2 this level as the reference. This output is output from pin 2.

**Figure 9: Pin 19 (PEAK HOLD) Peripheral Circuit**

- Pin 20 (V SEP R): The resistor that determines the vertical synchronization separation is connected to this pin.

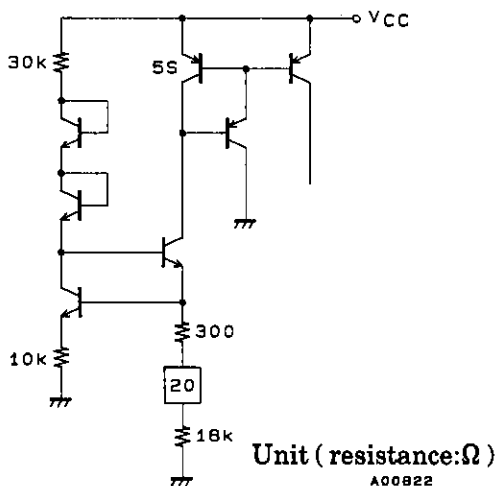

The LA7945N performs vertical synchronization separation by charging an internal capacitor using the fixed current determined by the resistor connected to this pin as the reference. The pin 20 DC voltage is 1/4 V<sub>CC</sub>.

**Figure 10: Pin 20 (V SEP R) Peripheral Circuit**



## LA7945N

- Pin 21: The vertical synchronization separation output pin.

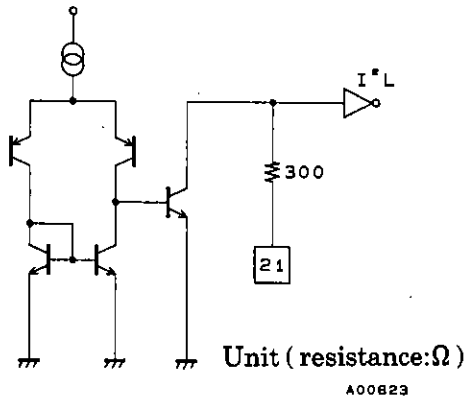

The signal passed to the vertical C/D from vertical synchronization separation is output from pin 21. Since vertical C/D is I<sup>2</sup>L, a signal of between 0 and 0.7 V is output. This pin is normally left open. The vertical C/D start position can be changed by an external override input.

**Figure 11: Pin 21 Peripheral Circuit**

- Pin 22: This pin determines whether or not the horizontal count for vertical C/D is changed every frame when the start bit is not detected.

When this pin is grounded, 21H is fixed, and it functions when open. Ground this pin when captions are used.

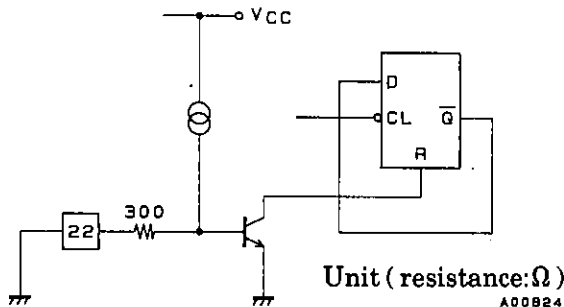

**Figure 12: Pin 22 Peripheral Circuit**

- No products described or contained herein are intended for use in surgical implants, life-support systems, aerospace equipment, nuclear power control systems, vehicles, disaster/crime-prevention equipment and the like, the failure of which may directly or indirectly cause injury, death or property loss.
- Anyone purchasing any products described or contained herein for an above-mentioned use shall:
  - ① Accept full responsibility and indemnify and defend SANYO ELECTRIC CO., LTD., its affiliates, subsidiaries and distributors and all their officers and employees, jointly and severally, against any and all claims and litigation and all damages, cost and expenses associated with such use:
  - ② Not impose any responsibility for any fault or negligence which may be cited in any such claim or litigation on SANYO ELECTRIC CO., LTD., its affiliates, subsidiaries and distributors or any of their officers and employees jointly or severally.
- Information (including circuit diagrams and circuit parameters) herein is for example only; it is not guaranteed for volume production. SANYO believes information herein is accurate and reliable, but no guarantees are made or implied regarding its use or any infringements of intellectual property rights or other rights of third parties.