

Monolithic Linear IC



LA8608V

1.8 V Low-Voltage Narrowband FM-IF System

Overview

The LA8608V is a narrowband FM-IF system intended for communications equipment, operates at just 1.8 V, and is contained in an ultrasmall package with a 0.65 mm pitch. In addition to the various functions needed for reception, the LA8608V also offers other functions such as noise detection and electric field intensity detection, and is optimum for compact designs, such as for cordless phones.

Functions

- 2nd mixer, 2nd local oscillator, IF amplifier, limiter, quadrature detector, signal meter
- Noise detector, noise amplifier, noise detector, Schmitt trigger, comparator

Features

- Because this IC has three independent noise detection and amplification amplifiers, it can be used to form a secondary biquad bandpass filter; furthermore, because it is equipped with detector and Schmitt trigger functions, it can be easily used for carrier sense applications.
- Broad signal meter linearity (70 dB typ.)
- Low operating voltage: 1.8 V to 6 V
- Small package: SSOP-24 (0.65 mm pitch)

Package Dimensions

unit : mm

3175A-SSOP24

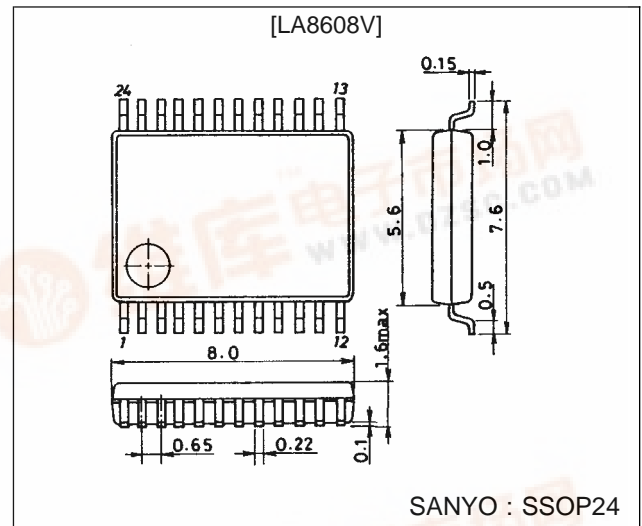

Specifications

Maximum Ratings at Ta = 25 °C

| Parameter | Symbol | Conditions | Ratings | Unit |
|-----------------------------|---------------------|------------|-------------|------|
| Maximum supply voltage | V _{CC} max | | 8.0 | V |
| Allowable power dissipation | Pd max | | 300 | mW |
| Operating temperature | Topr | | -20 to +75 | °C |
| Storage temperature | Tstg | | -40 to +125 | °C |

Operating Conditions at Ta = 25 °C

| Parameter | Symbol | Conditions | Ratings | Unit |
|--------------------------------|--------------------|------------|------------|------|
| Recommended supply voltage | V _{CC} | | 3.0 | V |
| Operating supply voltage range | V _{CC} op | | 1.8 to 6.0 | V |



LA8608V

Operating Characteristics at $T_a = 25\text{ }^\circ\text{C}$, $V_{CC} = 3\text{ V}$, $f_C = 21.7\text{ MHz}$, $f_{mod} = 1\text{ kHz}$, $dev = \pm 3\text{ kHz}$

| Parameter | Symbol | Output | min | typ | max | Unit |
|-------------------------------|---------------|--|-----|-----|-----|------------|
| Quiescent current | I_{CCO} | No input | | 2.8 | 3.8 | mA |
| -3 dB limiting sensitivity | -3dBLS. | -3 dB | | 5 | 11 | dB μ |
| Demodulation output | V_O | $V_{in} = 80\text{ dB}\mu$ | 115 | 170 | 230 | mVrms |
| S/N ratio | S/N(1) | $V_{in} = 80\text{ dB}\mu$, Non-modulation | 54 | 60 | | dB |
| | S/N(2) | $V_{in} = 20\text{ dB}\mu$, Non-modulation | 20 | 25 | | dB |
| AM rejection ratio | AMR | $V_{in} = 80\text{ dB}\mu$, AM 30% modulation | 30 | 40 | | dB |
| Total harmonic distortion | THD | $V_{in} = 80\text{ dB}\mu$ | | 0.7 | 2.0 | % |
| Noise detection output | $V_{ND}(1)$ | $V_{in} = 10\text{ dB}\mu$, $V_{CC} = 2.1\text{ V}$ | | 1.9 | | V |
| | $V_{ND}(2)$ | $V_{in} = 10\text{ dB}\mu$, $V_{CC} = 3.0\text{ V}$ | 1.6 | 2.2 | 2.8 | V |
| | $V_{ND}(3)$ | $V_{in} = 10\text{ dB}\mu$, $V_{CC} = 5.0\text{ V}$ | | 2.3 | | V |
| | $V_{ND}(4)$ | $V_{in} = 30\text{ dB}\mu$ | | 0 | 0.1 | V |
| Schmitt trigger level | SH | | 12 | 20 | 27 | dB μ |
| Schmitt hysteresis | SHhy | | | 1 | | dB |
| Schmitt output level | $V_{SH}(1)$ | $V_{in} = 13\text{ dB}\mu$ | | | 0.5 | V |
| | $V_{SH}(2)$ | $V_{in} = 26\text{ dB}\mu$ | 2.8 | | | V |
| Signal meter output | $V_{SM}(1)$ | $V_{in} = 5\text{ dB}\mu$ | | 0.1 | 0.3 | V |
| | $V_{SM}(2)$ | $V_{in} = 50\text{ dB}\mu$ | 0.8 | 1.1 | 1.4 | V |
| | $V_{SM}(3)$ | $V_{in} = 80\text{ dB}\mu$ | 1.3 | 1.6 | 2.0 | V |
| Comparator output | $V_{COMP}(1)$ | $V_g = 1.5\text{ V}$ | 2.8 | | | V |
| | $V_{COMP}(2)$ | $V_g = 0.9\text{ V}$ | | | 0.5 | V |
| Mixer conversion gain | G_M | | | 20 | | dB |
| Mixer input frequency | | | | | 90 | MHz |
| Mixer input resistance | | | | 3.6 | | k Ω |
| Mixer output resistance | | | | 1.8 | | k Ω |
| IF input resistance | | | | 1.8 | | k Ω |
| FM detection output impedance | | | | 2.4 | | k Ω |

LA8608V

Block Diagram and Pin Assignment

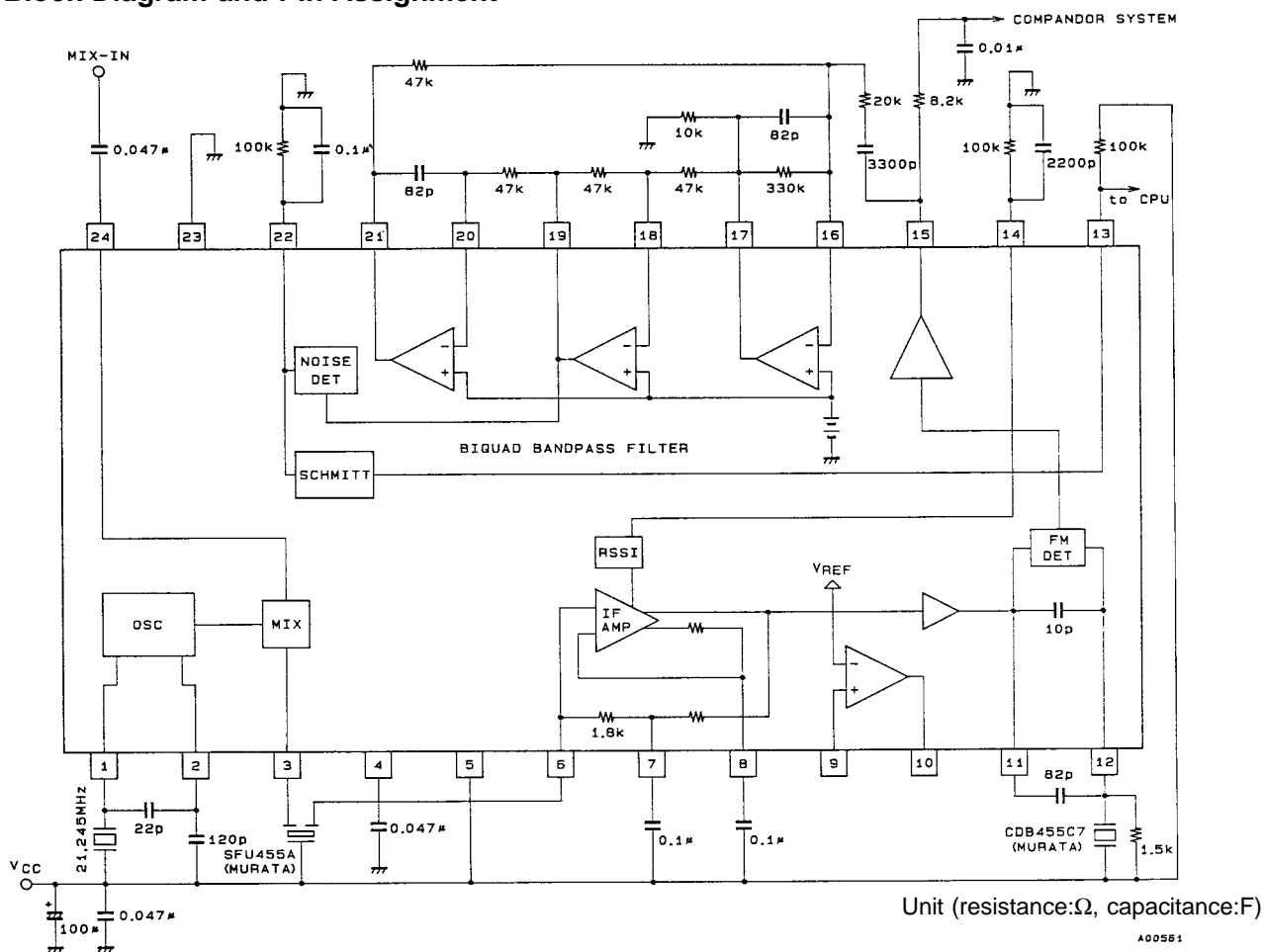

Pins

- | | | |
|---------------------|-----------------|----------------|
| 1. CRYSTAL | 9. COMP(+) | 17. OUT1 |
| 2. OSC | 10. COMP-OUT | 18. IN(-)2 |
| 3. MIX-OUT | 11. LIMIT.OUT | 19. OUT2 |
| 4. V _{REF} | 12. QUAD-COIL | 20. IN(-)3 |
| 5. V _{CC} | 13. SCHMITT-OUT | 21. OUT3 |
| 6. IF-IN | 14. S.DET. | 22. NOISE-DET. |
| 7. D.C1 | 15. DET-OUT | 23. GND |
| 8. D.C2 | 16. IN(-)1 | 24. MIX-IN |

LA8608V

AC Test Circuit

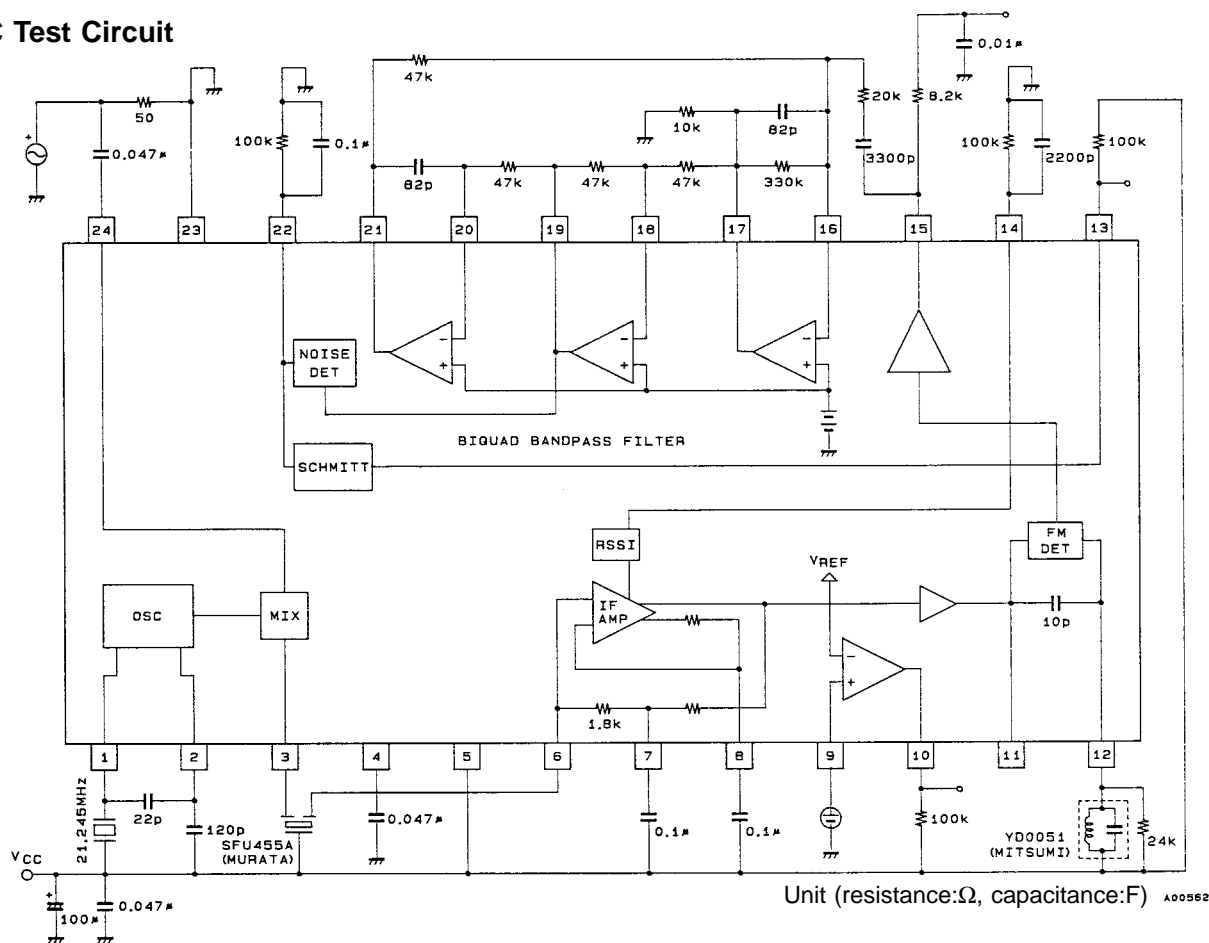

Sample Application Circuit (1)

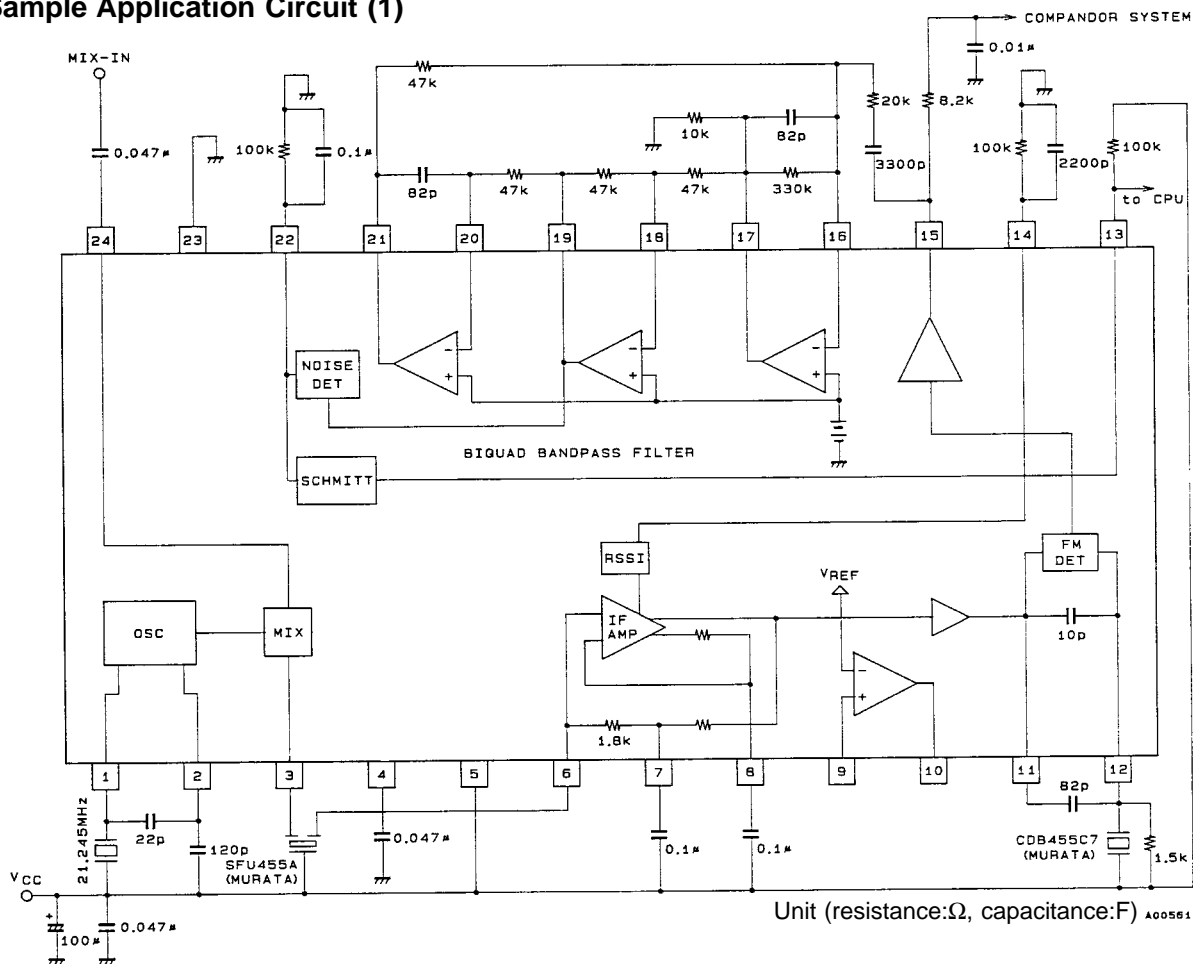

LA8608V

Sample Application Circuit (2)

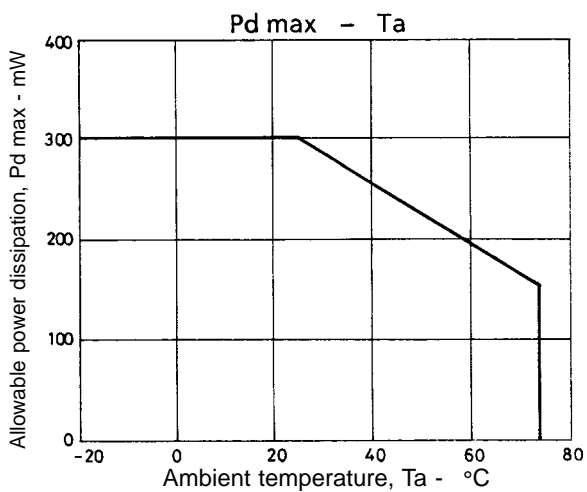
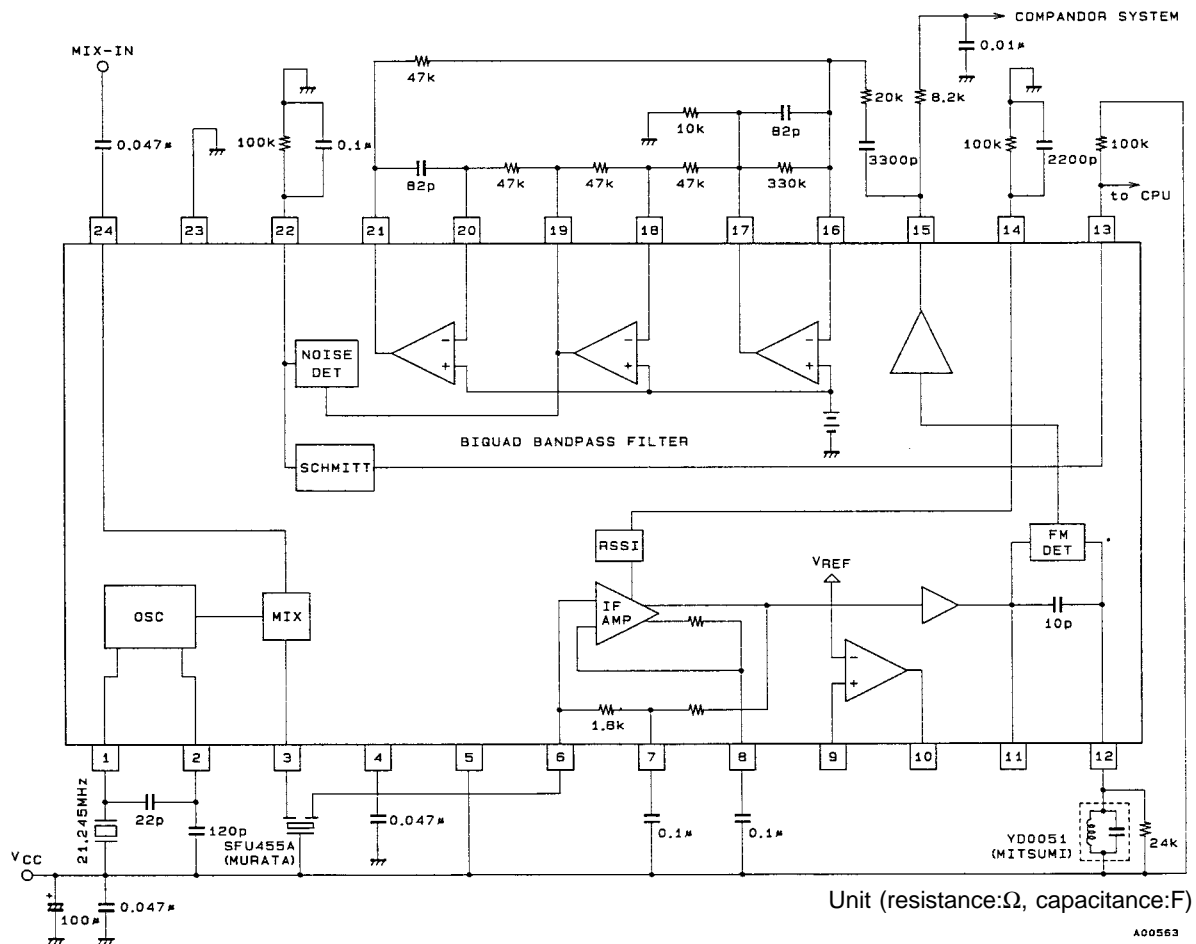

LA8608V

Pin Description

Unit (resistance:Ω)

| Pin No. | Pin Name | Pin Voltage [V] | Internal equivalent circuit | Remarks |
|---------|-------------|-----------------|-----------------------------|--|
| 1 | CRYSTAL | V_{CC} | | Forms a Colpitts oscillator. |
| 2 | OSC | $V_{CC}-0.7$ | | |
| 3 | MIX-OUT | $V_{CC}-0.3$ | | MIX buffer output |
| 4 | VREF | 1.2V | | Regulated voltage output |
| 5 | V_{CC} | V_{CC} | | Power supply |
| 6 | IF-IN | $V_{CC}-0.9$ | | IF amp input |
| 7 | D.C1 | $V_{CC}-0.9$ | | IF amp DC feedback |
| 8 | D.C2 | $V_{CC}-0.9$ | | |
| 9 | COMP (+) | | | Comparator threshold setting pin; set by external resistance |
| 10 | COMP-OUT | | | Comparator output; open collector |
| 11 | LIM.OUT | 0.2 | | Limiter amp output |
| 12 | QUAD-COIL | V_{CC} | | Discriminator connection |
| 13 | SCHMITT-OUT | | | Noise Schmitt output; open collector |

Continued on next page.

LA8608V

Continued from preceding page.

Unit (resistance:Ω)

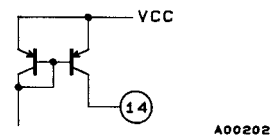
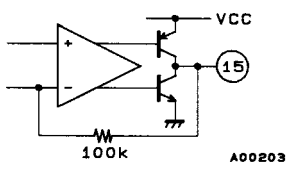
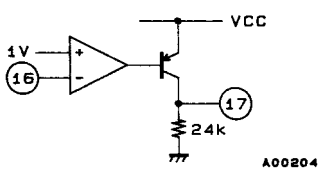
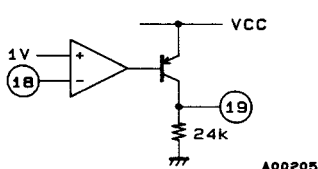
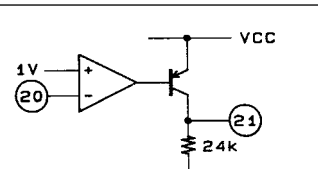
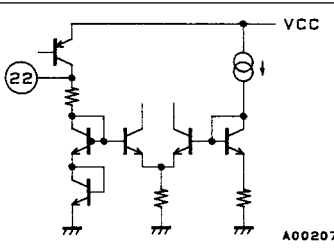
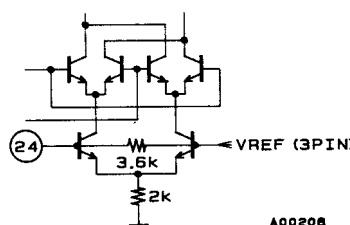
| Pin No. | Pin Name | Pin Voltage [V] | Internal equivalent circuit | Remarks |
|---------|-----------|-----------------|--|--|
| 14 | S.DET | 0.1 to 1.5 |  | Electric field intensity signal output |
| 15 | DET-OUT | 1.2 |  | FM detection output |
| 16 | IN (-)1 | 1.0 |  | Operational amplifier negative input |
| 17 | OUT1 | 1.0 | | Operational amplifier output |
| 18 | IN (-)2 | 1.0 |  | Operational amplifier negative input |
| 19 | OUT2 | 1.0 | | Operational amplifier output |
| 20 | IN (-)3 | 1.0 |  | Operational amplifier negative input |
| 21 | OUT3 | 1.0 | | Operational amplifier output |
| 22 | NOISE-DET | 0 to 1.4 |  | Noise wave detection output |
| 23 | GND | 0 | | GND |
| 24 | MIX-IN | 1.2 |  | Mixer input |

IC Usage Notes

1. About the local oscillator

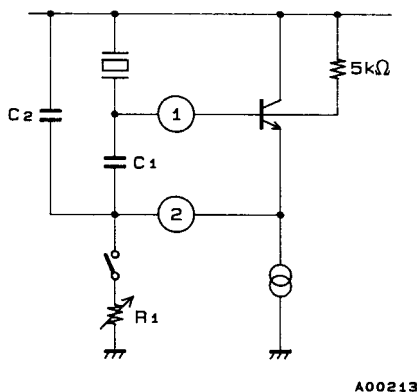

A00213

Fig. 1

Fig. 1 shows the equivalent circuit for the local oscillator.

In this circuit, when $C_1 = 22$ pF, the change in the negative resistance versus C_2 is shown in Fig. 2, the change in the operational load capacitance is shown in Fig. 3, and the frequency deviation is shown in Fig. 4. In the application circuit, $C_2 = 120$ pF, and in this case the negative resistance according to Fig. 2 is -58Ω . In order to increase the negative resistance, it is necessary to decrease the value of C_2 . To increase the oscillation level, it is possible to add external resistor R_1 and raise the local oscillator current. However, the oscillation level on pin 1 must be set to 110 dB or less. If set to a greater level, distortion will occur in the oscillation waveform.

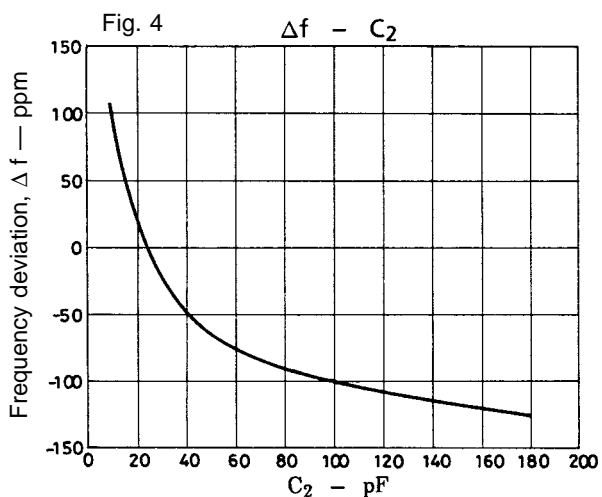
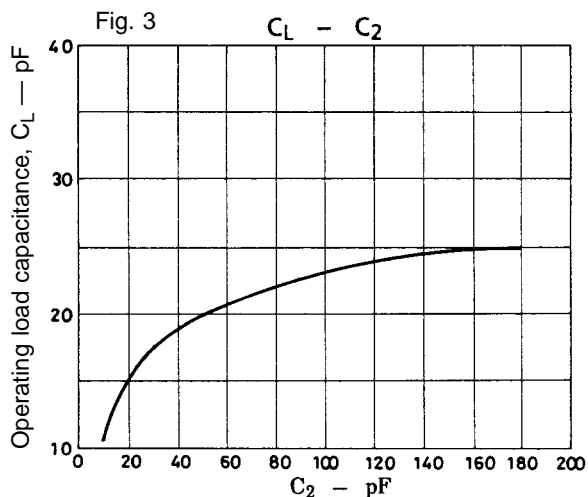
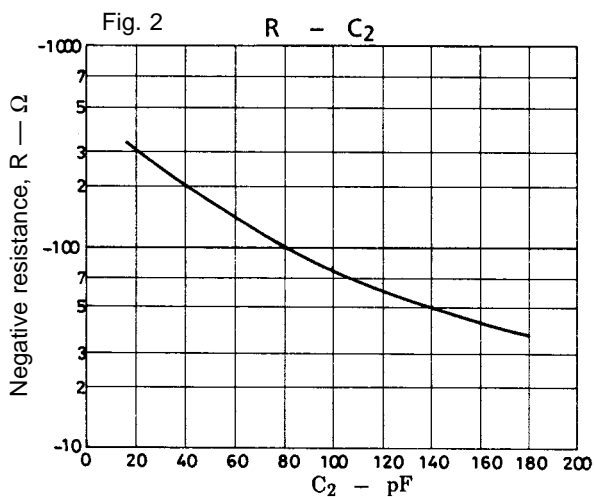

(Note)
 Fig 2 to 4: $C_1 = 22$ pF
 Figs. 3, 4: Reference to operating load capacitance 16 pF

LA8608V

2. About the built-in operational amplifiers

The LA8608V has three independent operational amplifiers on chip that can be used as needed. If they are not to be used, short the I/O pins.

Sample application 1: Noise amplifier

Using the three operational amplifiers, it is possible to form a secondary biquad bandpass filter. (For details on the filter response characteristics, refer to the data provided later.)

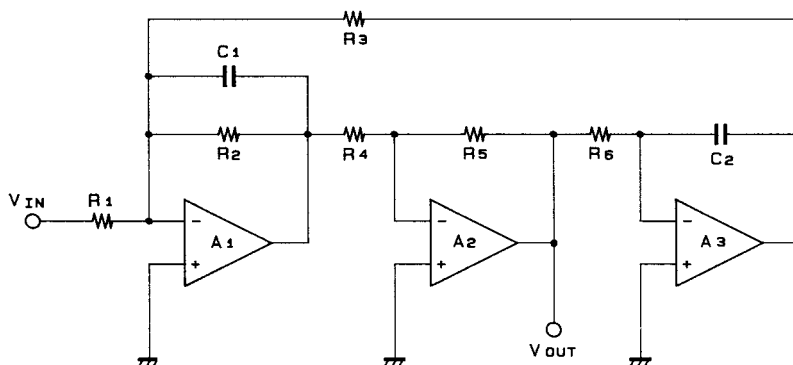

Fig. 5

A00215

The calculation of the transfer function for the above diagram is as shown below.

$$\omega_0^2 = \frac{R_5}{C_1 C_2 R_3 R_4 R_6}$$

$$\frac{\omega_0}{Q} = \frac{1}{C_1 R_2}$$

$$H = \frac{R_2 R_5}{R_1 R_4}$$

In normal use, $R_3 = R_4 = R_5 = R_6 = R_f$, and $C_1 = C_2 = C_f$:
Therefore,

$$\omega_0 = \frac{1}{C_f R_f} \quad Q = C_f R_2 \times \omega_0 \quad H = \frac{R_2 R_f}{R_1 R_f}$$

$$f_0 = \frac{1}{2\pi C_f R_f} \quad = \frac{R_2}{R_f} \quad = \frac{R_2}{R_1}$$

f_0 = center frequency, H = pass band gain, Q = selectivity

LA8608V

Noise amplified by this amp passes through the noise detector, and is detected by R and C connected to pin 22. The Schmitt circuit operates on the basis of this DC, and the Schmitt output appears on pin 13. Because the pass band gain is determined by R_2/R_1 , changing these resistances makes it possible to vary the Schmitt circuit level to some extent. By varying the level, it is possible to continue operating Schmitt circuit up to a signal-to-noise ratio of approximately 30 dB on the No. 2 mixer input. To continue operating Schmitt circuit at a higher S/N ratio, add a resistor between pin 17 and GND. This makes it possible to increase the signal-to-noise ratio of the input level at which the Schmitt circuit continue operating by approximately 10 dB. (Refer to Fig. 6.)

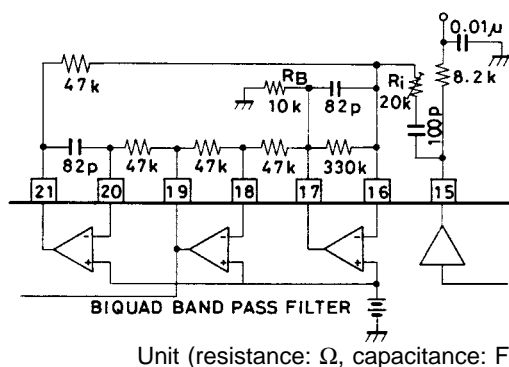
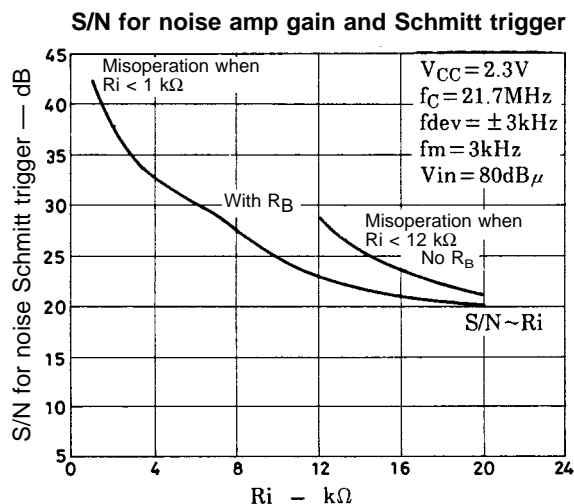

Fig. 6

Sample application 2:

- (1) When an operational amplifier is used in a signal system amplifier, etc., connect a capacitor of about 1000 pF between the output (pins 17, 19, 21) and GND. This capacitor prevents local oscillation when the signal is clipped on the negative side.

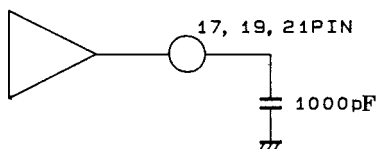

Fig. 7 A00216

- (2) When used in the signal system amplifier, etc. and the dynamic range of the output must be expanded, use the scheme described below.

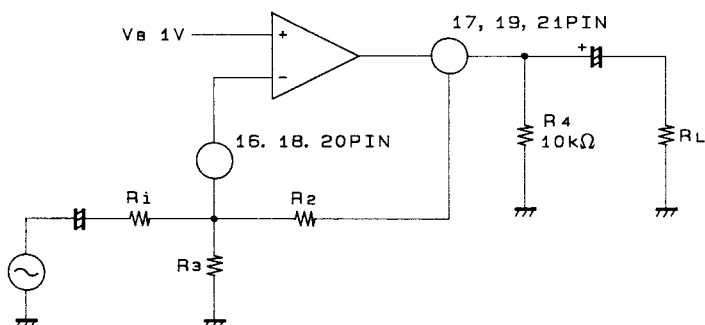

Fig. 8 A00217

- 1) Use R_{B1} to set the output DC voltage to approximately $1/2V_{CC}$.
Output DC voltage

$$V_{ODC} = V_B \left(1 + \frac{R_2}{R_3} \right)$$

$$V_B = 1 \text{ V}$$

- 2) Add 10 kΩ between the output pin and GND.

LA8608V

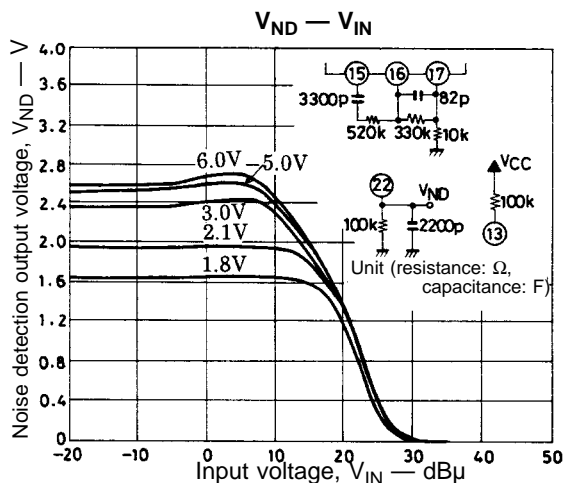
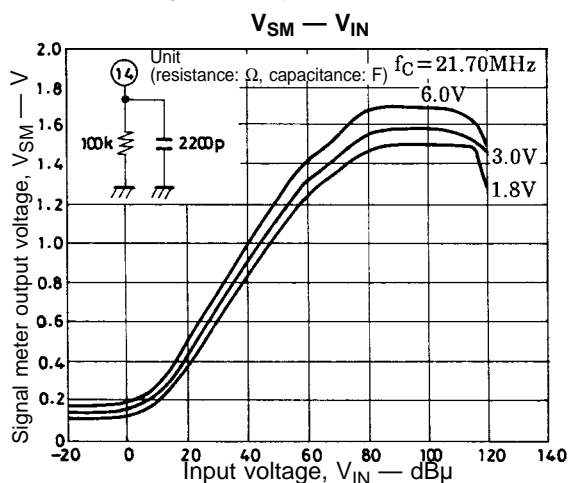
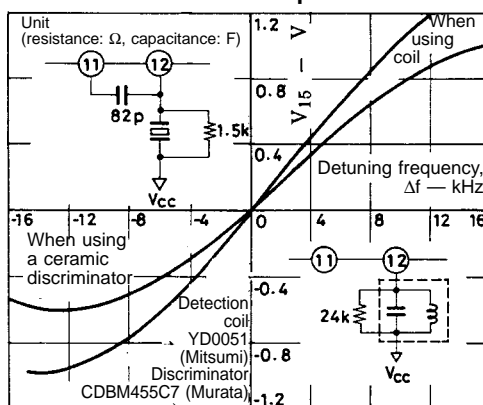
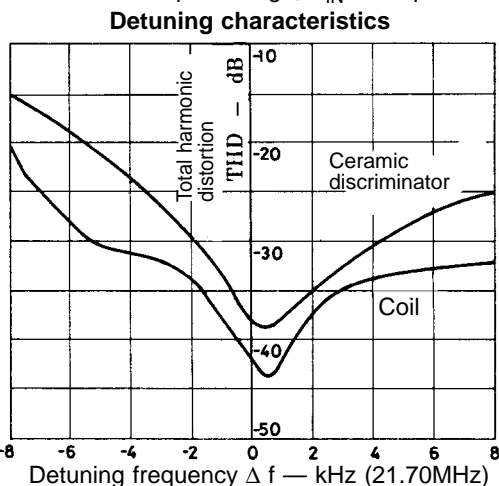
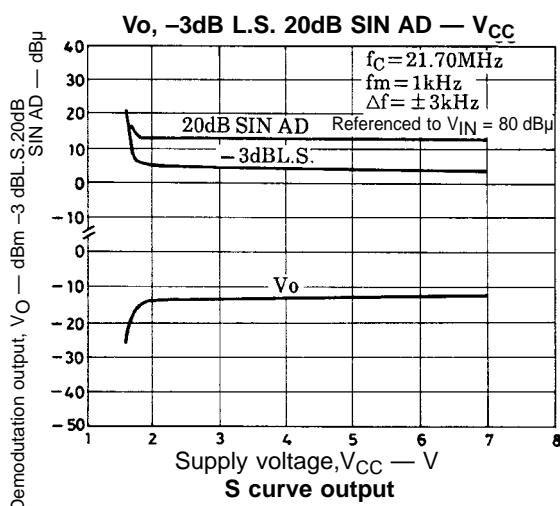
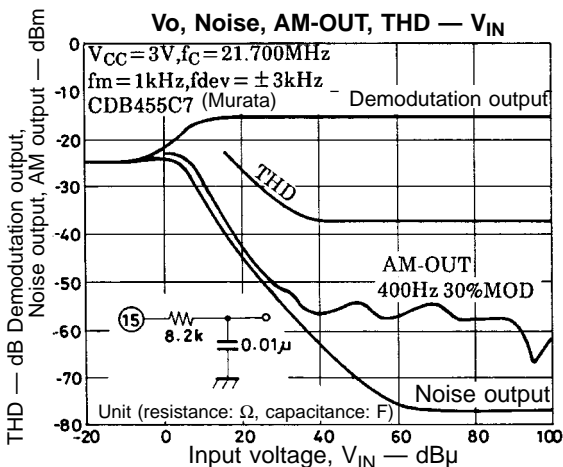
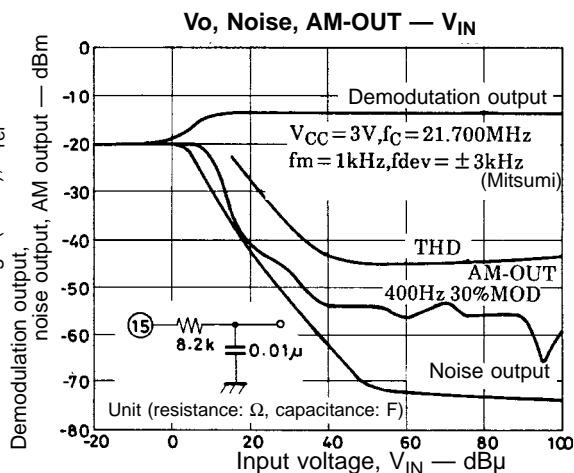
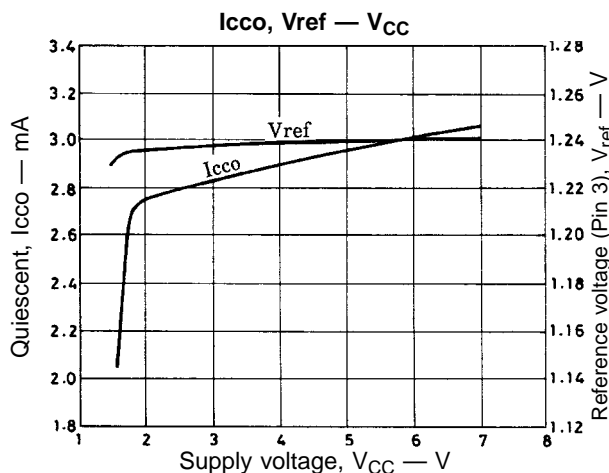

LA8608V

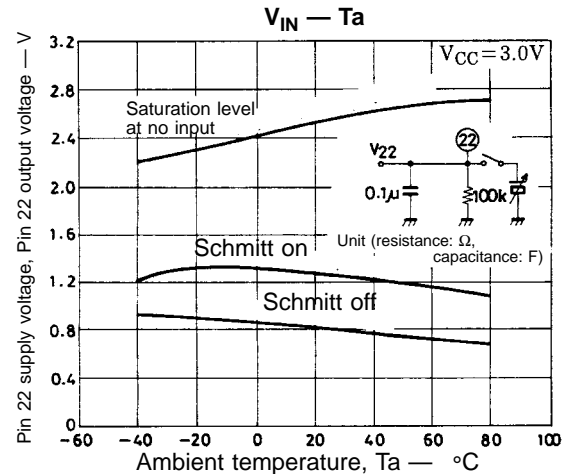
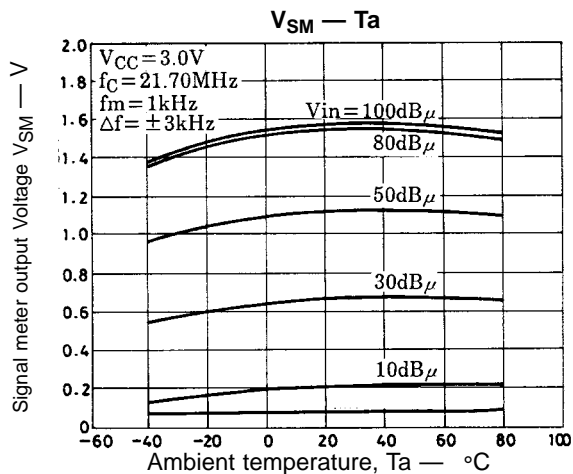
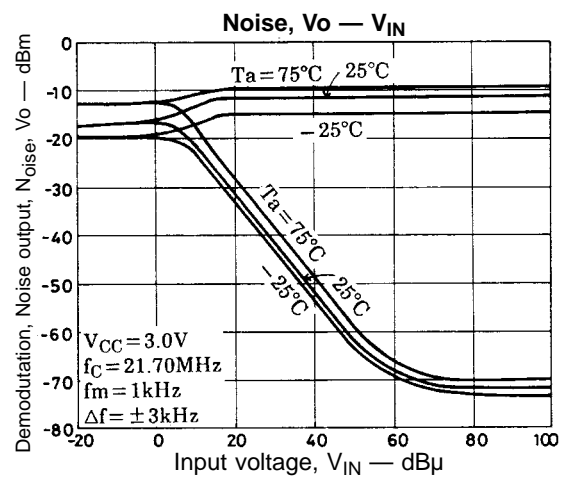
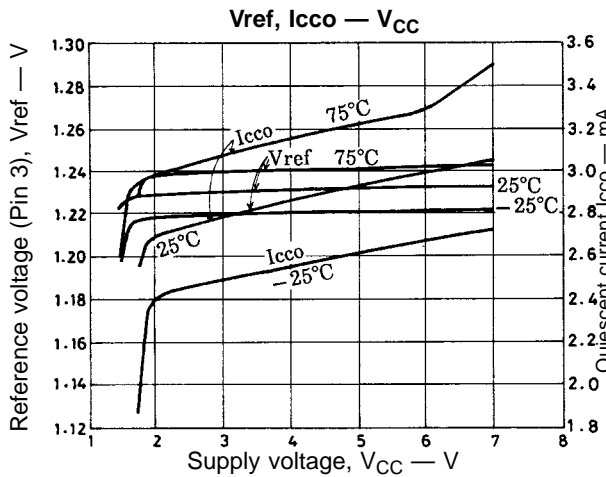
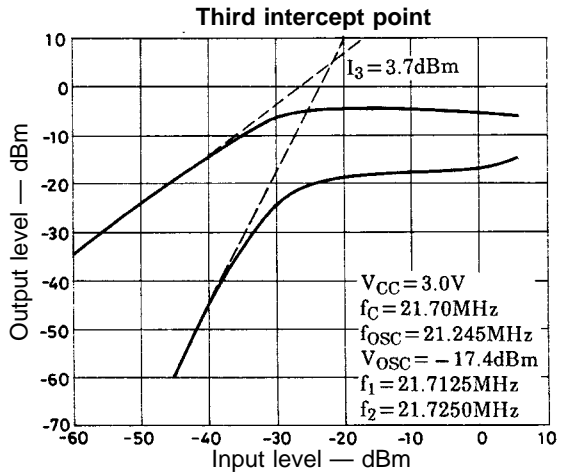
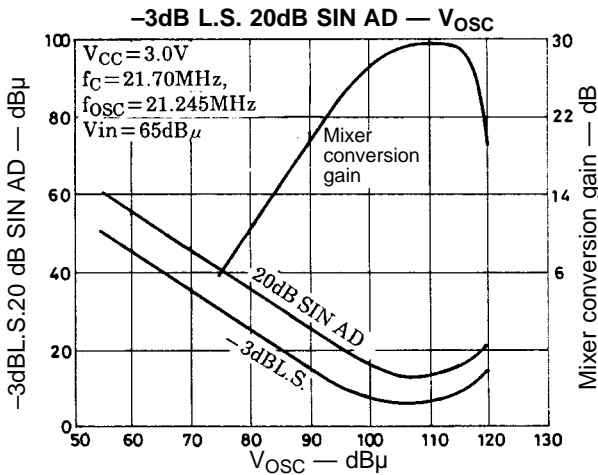
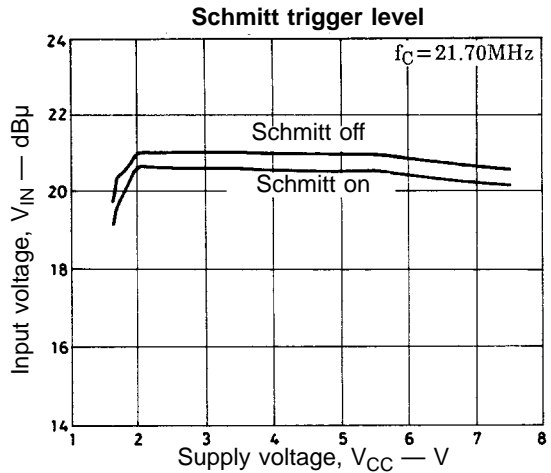
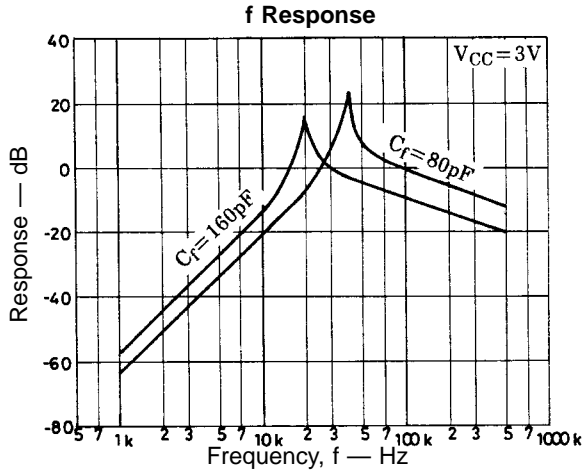

LA8608V

S curve output temperature characteristics (1)

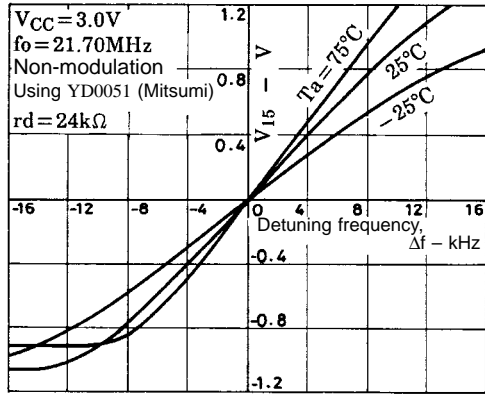

S curve output temperature characteristics (2)

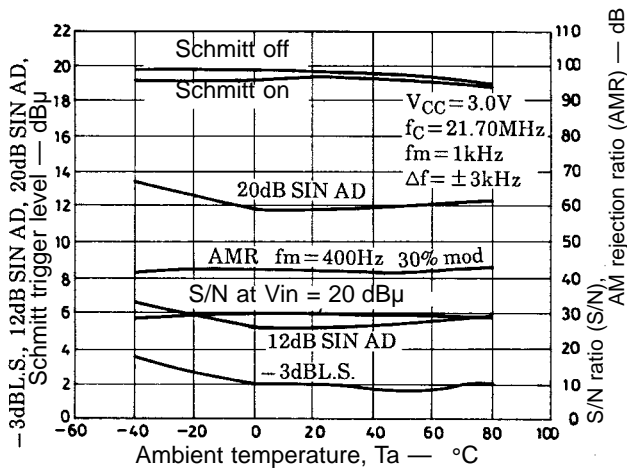
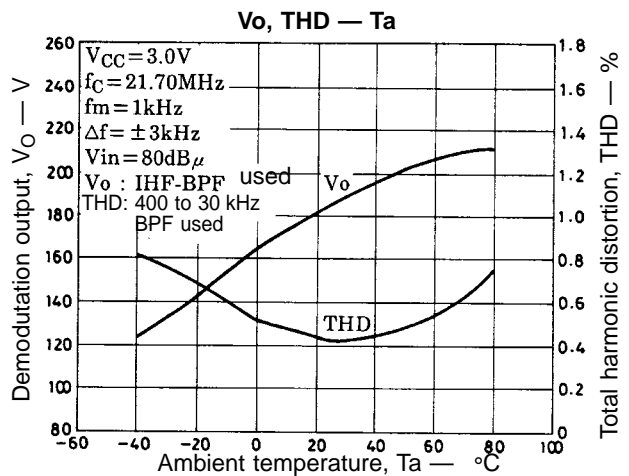
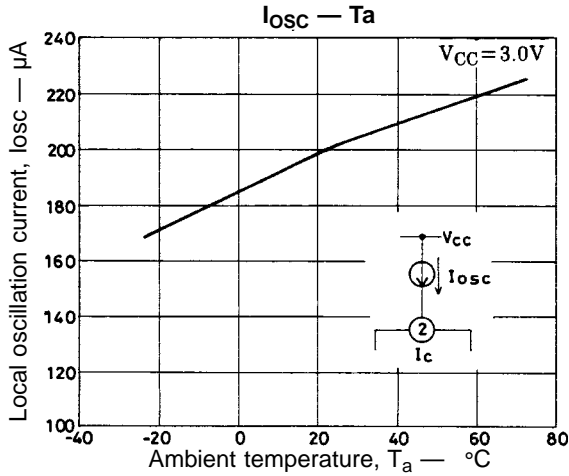
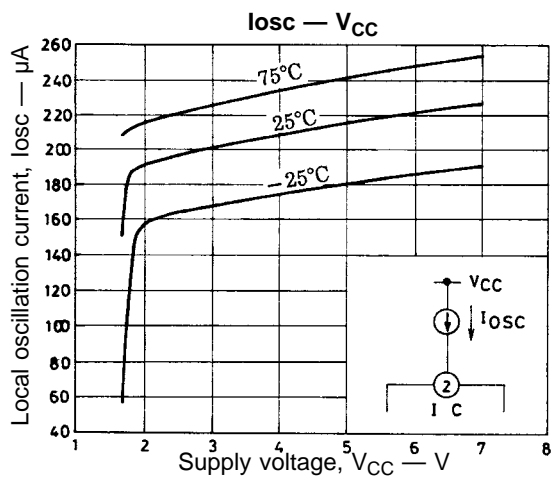
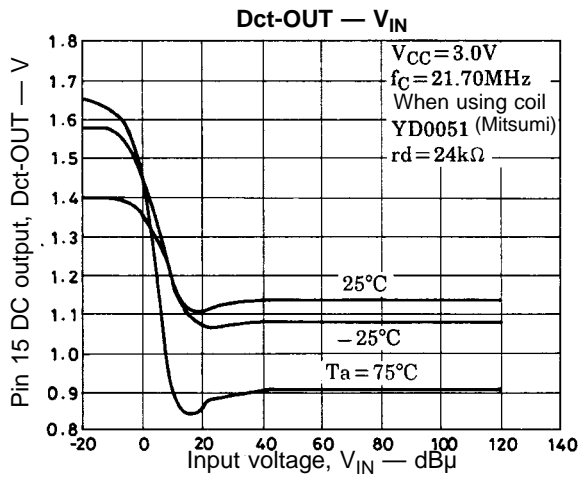
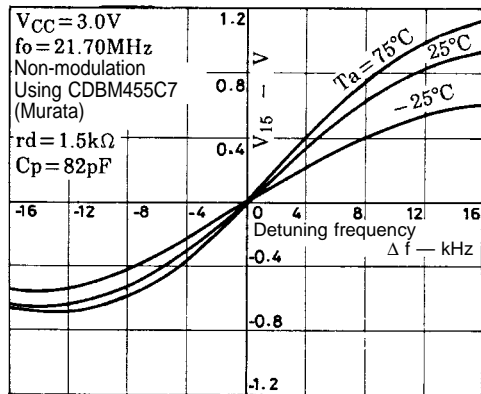

LA8608V

- No products described or contained herein are intended for use in surgical implants, life-support systems, aerospace equipment, nuclear power control systems, vehicles, disaster/crime-prevention equipment and the like, the failure of which may directly or indirectly cause injury, death or property loss.
- Anyone purchasing any products described or contained herein for an above-mentioned use shall:
 - ① Accept full responsibility and indemnify and defend SANYO ELECTRIC CO., LTD., its affiliates, subsidiaries and distributors and all their officers and employees, jointly and severally, against any and all claims and litigation and all damages, cost and expenses associated with such use:
 - ② Not impose any responsibility for any fault or negligence which may be cited in any such claim or litigation on SANYO ELECTRIC CO., LTD., its affiliates, subsidiaries and distributors or any of their officers and employees jointly or severally.
- Information (including circuit diagrams and circuit parameters) herein is for example only; it is not guaranteed for volume production. SANYO believes information herein is accurate and reliable, but no guarantees are made or implied regarding its use or any infringements of intellectual property rights or other rights of third parties.