



LB11999, 11999H

Three-Phase Brushless Motor Drivers for CD-ROM Spindle Motor Driver (supports 44×, 48×, 50×)

Features

- Current linear drive
- Control V type amplifier
- Separate power supply for output upper side bias circuit allows low output saturation by boosting this power supply only (useful for 5V power supply types).
- Upper side current detection technique loses loss voltage of current detection resistor. Voltage drop caused by this resistor reduces internal power dissipation of IC.
- Built-in short braking circuit
- Built-in reverse blocking circuit
- Hall FG output
- Built-in S/S function
- Built-in current limiter circuit (selectable, 2 steps)
- Built-in Hall power supply
- Built-in thermal shutdown circuit
- Supports 3.3V DSP

Package Dimensions

unit: mm

3227-HSOP24

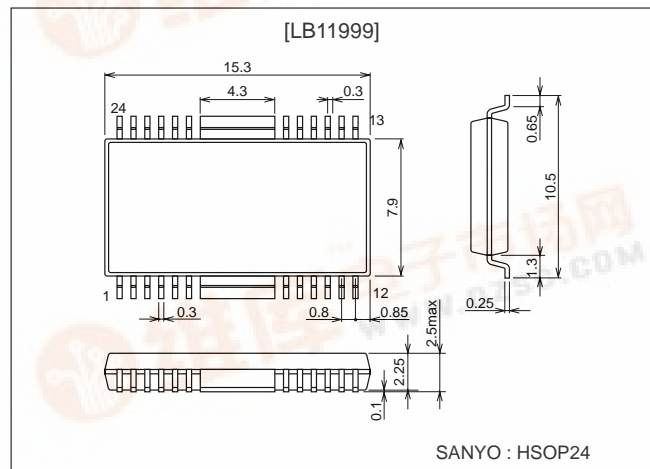

3234-HSOP28HC

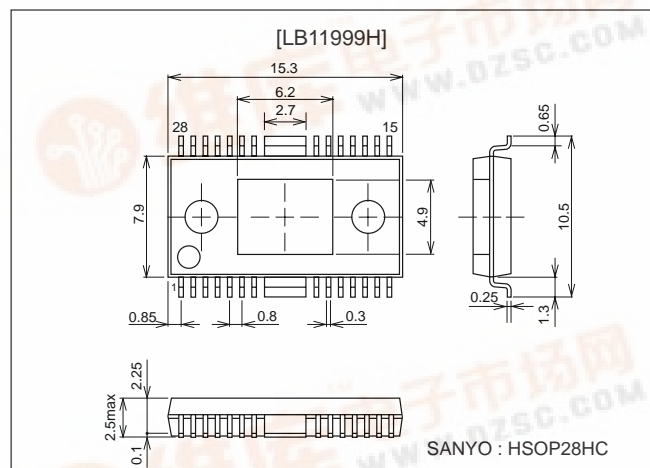

■ Any and all SANYO products described or contained herein do not have specifications that can handle applications that require extremely high levels of reliability, such as life-support systems, aircraft's control systems, or other applications whose failure can be reasonably expected to result in serious physical and/or material damage. Consult with your SANYO representative nearest you before using any SANYO products described or contained herein in such applications.

■ SANYO assumes no responsibility for equipment failures that result from using products at values that exceed, even momentarily, rated values (such as maximum ratings, operating condition ranges, or other parameters) listed in products specifications of any and all SANYO products described or contained herein.



LB11999,11999H

Specifications

Absolute Maximum Ratings at Ta = 25°C

Parameter	Symbol	Conditions	Ratings	Unit
Maximum power supply voltage 1	VCC1max		7.0	V
Maximum power supply voltage 2	VCC2max		14.4	V
Maximum power supply voltage 3	VCC3max		14.4	V
Maximum applied output voltage	Vomax		14.4	V
Maximum applied input voltage	Vimax		VCC1	V
Maximum output current	Iomax		1.3	A
Allowable power dissipation	Pdmax	*With specified substrate	0.8 (*1.9)	W
Operating temperature	Topr		-20 to +75	°C
Storage temperature	Tstr		-55 to +150	°C

Allowable Operating Ranges at Ta = 25°C

Parameter	Symbol	Conditions	Ratings	Unit
Power supply voltage 1	VCC1		4 to 6	V
Power supply voltage 2	VCC2	≥VCC1	4 to 13.6	V
Power supply voltage 3	VCC3		4 to 13.6	V

Application Example at Ta = 25°C

(1) 12V type

Power supply pin	Conditions	Ratings	Unit
VCC1	Regulated voltage	4 to 6	V
VCC2 = VCC3	Unregulated voltage	4 to 13.6	V

(2) 5V type

Power supply pin	Conditions	Ratings	Unit
VCC1 = VCC3	Regulated voltage	4 to 6	V
VCC2	Boost-up voltage or regulated voltage (Note)	4 to 13.6	V

Note: When boost-up voltage is used at VCC2, output can be set to low-saturation.

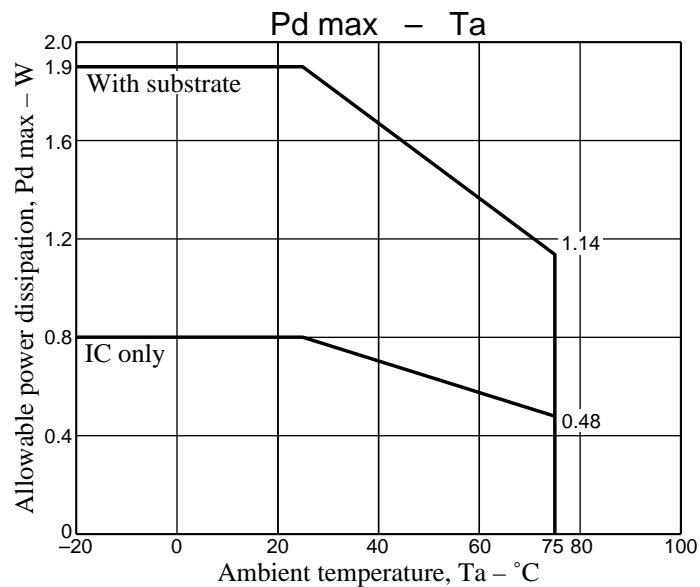

LB11999,11999H

Electrical Characteristics at Ta = 25°C, Vcc1 = 5V, Vcc2 = Vcc3 = 12V (unless otherwise specified)

Parameter	Symbol	Conditions	Ratings			Unit	
			min	typ	max		
[Power supply current]							
Power supply current 1	ICC1	VC = VCREF		8		mA	1
Power supply current 2	ICC2	VC = VCREF		0		mA	2
Power supply current 3	ICC3	VC = VCREF		150	250	μA	3
Output idle current 1	ICC1OQ	VS/S = 0V			200	μA	4
Output idle current 2	ICC2OQ	VS/S = 0V			30	μA	5
Output idle current 3	ICC3OQ	VS/S = 0V			30	μA	6
[Output]							
Saturation voltage, upper side 1	VOU1	IO = -0.5A, VCC1 = 5V, VCC2 = VCC3 = 12V		1.0		V	7
Saturation voltage, lower side 1	VOD1	IO = 0.5A, VCC1 = 5V, VCC2 = VCC3 = 12V		0.3		V	8
Saturation voltage, upper side 2	VOU2	IO = -0.5A, VCC1 = VCC3 = 5V, VCC2 = 12V		0.3		V	9
Saturation voltage, lower side 2	VOD2	IO = 0.5A, VCC1 = VCC3 = 5V, VCC2 = 12V		0.3		V	10
Current limiter setting voltage	VCL1	RRF = 0.33Ω, LMC: OPEN		0.24		V	11
	VCL2	RRF = 0.33Ω, LMC: GND		0.37		V	11
[Hall amplifier]							
Common mode input voltage range	VHCOM		1.2		VCC1-1.0	V	12
Input bias current	VHIB			1		μA	13
Minimum Hall input level	VHIN		60			mVp-p	14
[S/S pin]							
High level voltage	VS/SH		2.0		VCC1	V	15
Low level voltage	VS/SL				0.7	V	16
Input current	IS/SI	VS/S = 5V			200	μA	17
Leak current	IS/SL	VS/S = 0V	-30			μA	18
[Control]							
VC pin input current	IVC	VC = VCREF = 1.65V			1	μA	19
VCREF pin input current	IVCREF	VC = VCREF = 1.65V			1	μA	20
Voltage gain	GVCO	ΔVRE/ΔVC		0.35		times	21
Startup voltage	VCTH	VCREF = 1.65V	1.5		1.8	V	22
Startup voltage width	ΔVCTH	VCREF = 1.65V	50		150	mV	23
[Hall power supply]							
Hall power supply voltage	VH	IH = 5 mA		0.8		V	24
Allowable current	IH		20			mA	25
[Thermal shutdown]							
Operating temperature	TTSD		150	180	210	°C	Target
Hysteresis	ΔTTSD			15		°C	Target
[Short braking]							
Brake pin at High level	VBRH		4		5	V	26
Brake pin at Low level	VBRL		0		1	V	26

Note:

- During S/S OFF (standby), the Hall comparator is at High.
- Items shown to be "Target" are not measured.

Truth Table

	Source Sink	Input			Control
		U	V	W	VC
1	Phase W → Phase V	H	H	L	H
	Phase V → Phase W				L
2	Phase W → Phase U	H	L	L	H
	Phase U → Phase W				L
3	Phase V → Phase W	L	L	H	H
	Phase W → Phase V				L
4	Phase U → Phase V	L	H	L	H
	Phase V → Phase U				L
5	Phase V → Phase U	H	L	H	H
	Phase U → Phase V				L
6	Phase U → Phase W	L	H	H	H
	Phase W → Phase U				L

Input:

H: Input 1 is higher in potential than input 2 by at least 0.2V.

L: Input 1 is lower in potential than input 2 by at least 0.2V.

Block Diagram

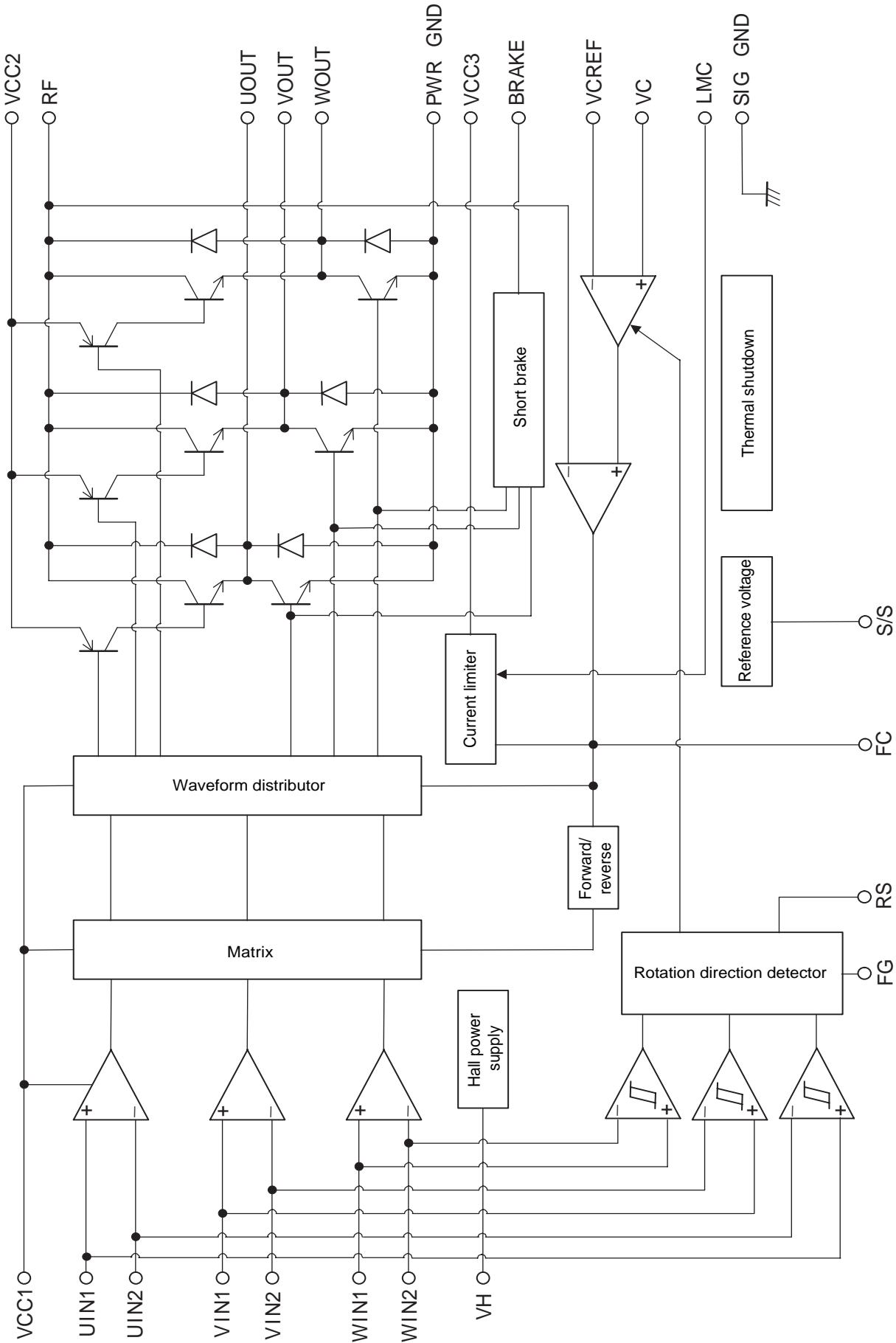

LB11999,11999H

Pin Assignment

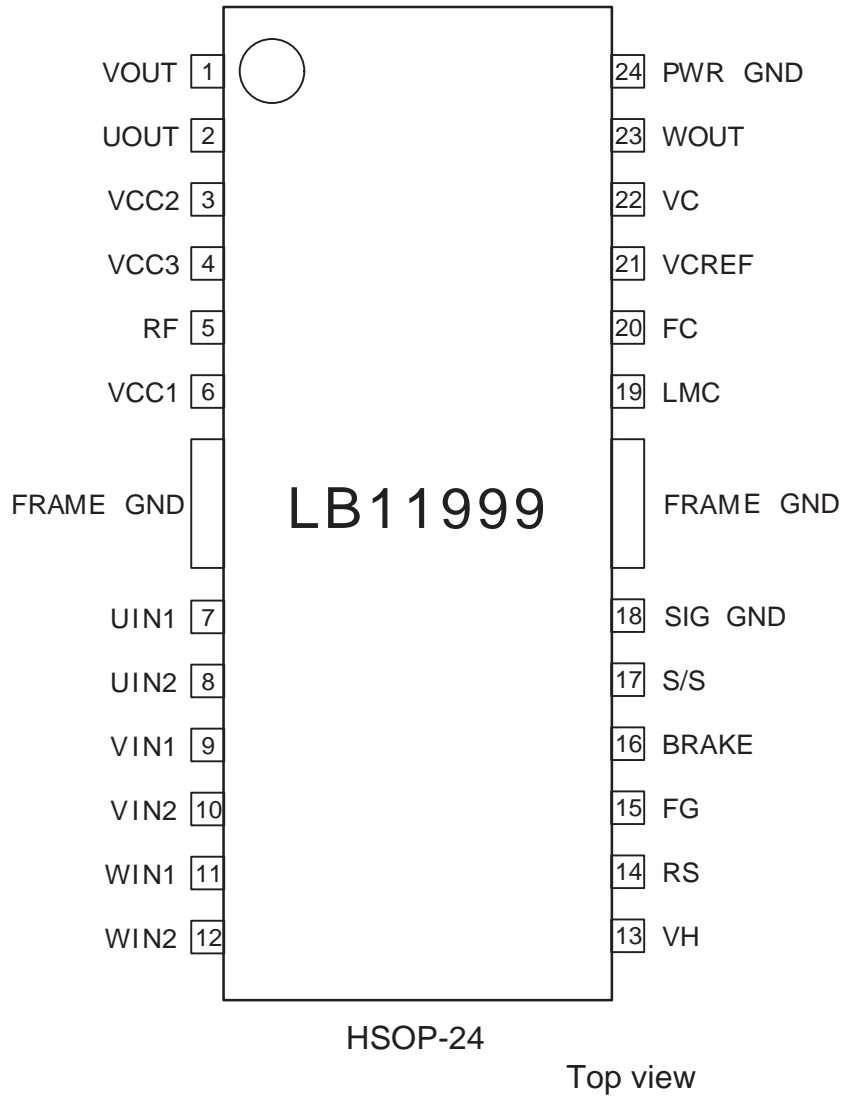

LB11999,11999H

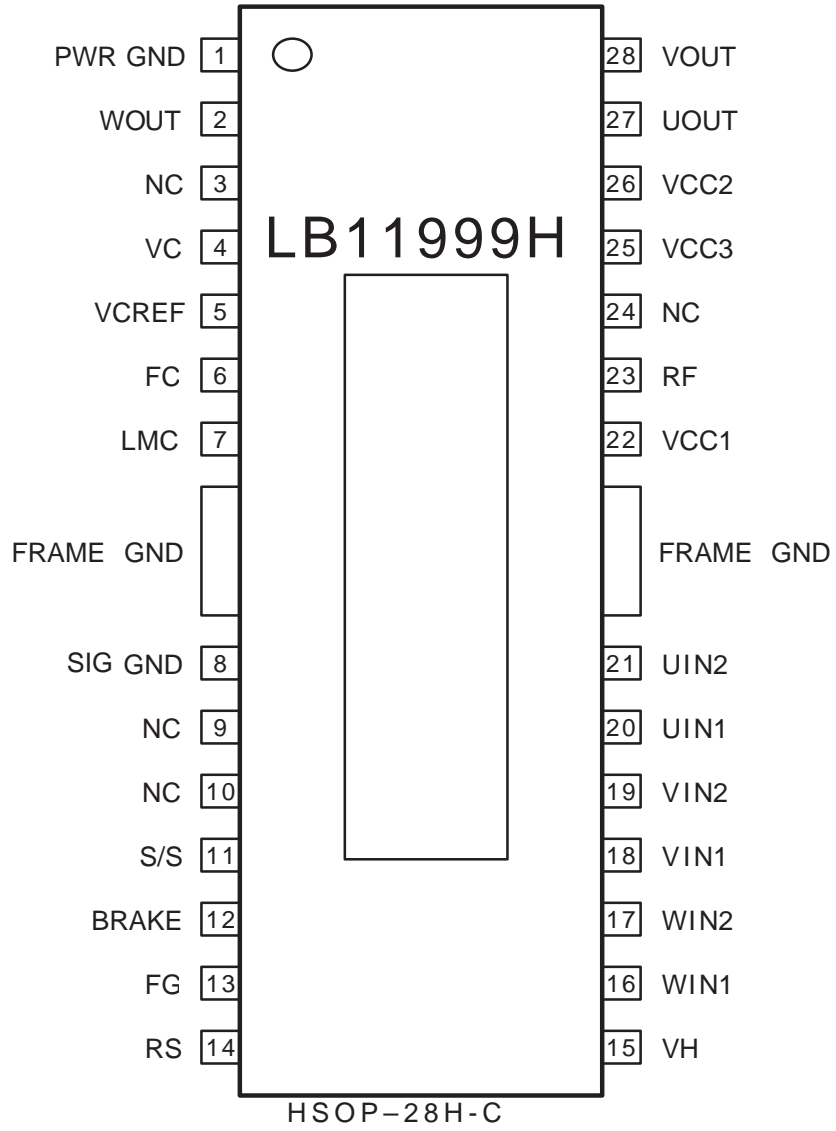

Top view

LB11999,11999H

Sample Application Circuit (LB11999)

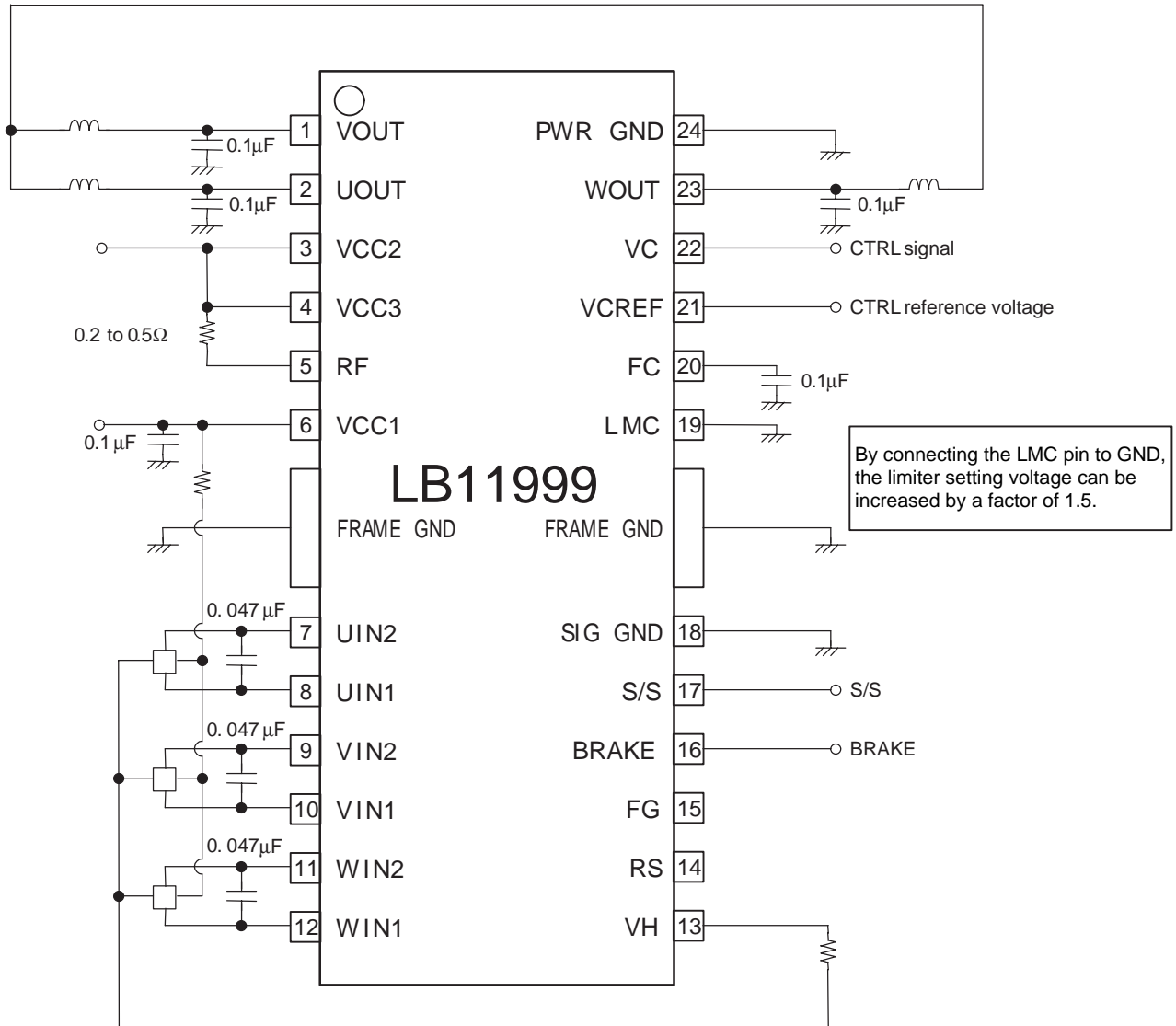

LB11999,11999H

Sample Application Circuit (LB11999H)

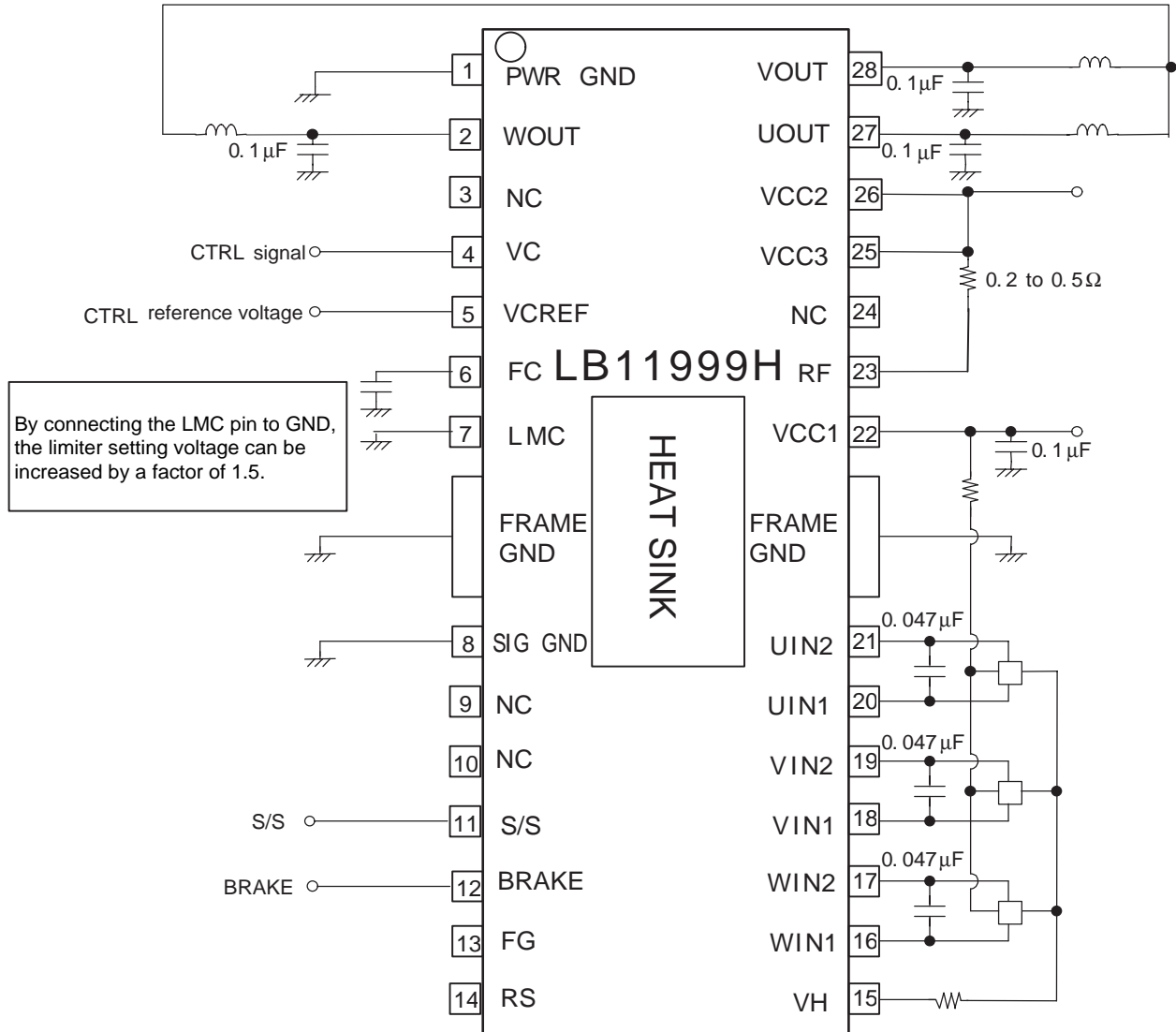

LB11999,11999H

Pin Description

* (): LB11999H

Unit (Resistance: Ω, capacitance: F)

Pin number	Pin name	Pin voltage	Equivalent circuit	Pin function
3 (26)	VCC2	4V to 13.6V		Source side predrive voltage supply pin.
4 (25)	VCC3	4V to 13.6V		Constant current control amplifier voltage supply pin.
6 (22)	VCC1	4V to 6V		Power supply pin for all voltage except output transistors, source predrive, and low current control amplifier.
14 (14)	RS			Reverse detector pin Forward rotation: High Reverse rotation: Low
15 (13)	FG			1 Hall element waveform Schmitt comparator composite output
8 (20)	UIN1	1.2V to VCC1-1V		U phase Hall element input and reverse detector U phase Schmitt comparator input pin. Logic High indicates UIN1 > UIN2.
7 (21)	UIN2			V phase Hall element input and reverse detector V phase Schmitt comparator input pin. Logic High indicates VIN1 > VIN2.
10 (18)	VIN1			W phase Hall element input and reverse detector W phase Schmitt comparator input pin. Logic High indicates WIN1 > WIN2.
9 (19)	VIN2			
12 (16)	WIN1			
11 (17)	WIN2			
13 (15)	VH			Hall element lower side bias voltage supply pin.
17 (11)	S/S	0V to VCC1		When this pin is at 0.7V or lower, or when it is open, all circuits are inactive. When driving motor, set this pin to 2V or higher.

Continued on next page

LB11999,11999H

Continued from preceding page

Unit (Resistance: Ω , capacitance: F)

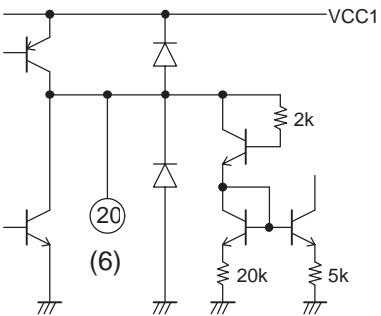
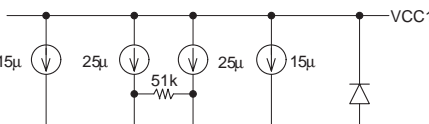
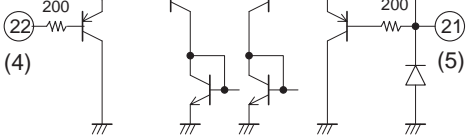
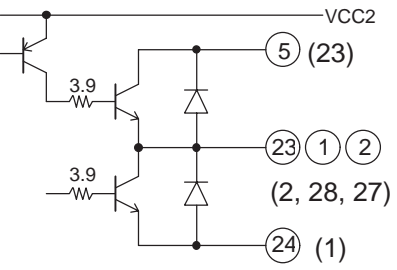
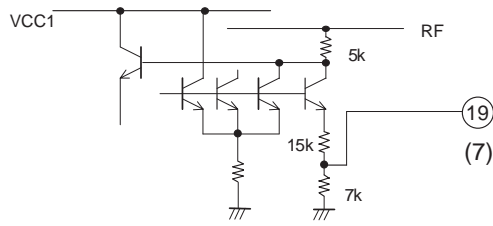
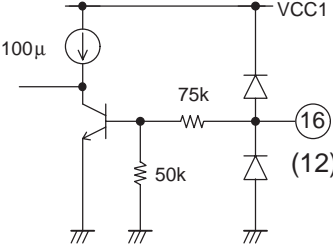
Pin number	Pin name	Pin voltage	Equivalent circuit	Pin function
18 (8)	SIG GND			GND pin for all circuits except output.
20 (6)	FC			Control loop frequency compensator pin. Connecting a capacitor between this pin and GND prevents closed loop oscillation in current limiting circuitry.
21 (5)	VCREF	1.3V to 2V		Control reference voltage applied pin. Determines control start voltage.
22 (4)	VC	0V to VCC1		Speed control voltage applied pin. V type control technique VC > VCREF : Forward VC < VCREF : Slowdown (Reverse-blocking circuit prevents reverse rotation.)
23 (2)	WOUT			W-phase output.
24 (1)	PWR GND			Output transistor GND.
1 (28)	VOUT			V-phase output.
2 (27)	UOUT			U-phase output.
5 (23)	RF			Upper side output NPN transistor collector pin (common for all 3 phases). For current detection, connect resistor between VCC3 pin and RF pin. Constant current control and current limiter works by detecting this voltage.
19 (7)	LMC			
16 (12)	BRAKE			Short brake pin. BRAKE: High -> Brake Low/Open -> Drive

- Specifications of any and all SANYO products described or contained herein stipulate the performance, characteristics, and functions of the described products in the independent state, and are not guarantees of the performance, characteristics, and functions of the described products as mounted in the customer's products or equipment. To verify symptoms and states that cannot be evaluated in an independent device, the customer should always evaluate and test devices mounted in the customer's products or equipment.
- SANYO Electric Co., Ltd. strives to supply high-quality high-reliability products. However, any and all semiconductor products fail with some probability. It is possible that these probabilistic failures could give rise to accidents or events that could endanger human lives, that could give rise to smoke or fire, or that could cause damage to other property. When designing equipment, adopt safety measures so that these kinds of accidents or events cannot occur. Such measures include but are not limited to protective circuits and error prevention circuits for safe design, redundant design, and structural design.
- In the event that any or all SANYO products(including technical data, services) described or contained herein are controlled under any of applicable local export control laws and regulations, such products must not be exported without obtaining the export license from the authorities concerned in accordance with the above law.
- No part of this publication may be reproduced or transmitted in any form or by any means, electronic or mechanical, including photocopying and recording, or any information storage or retrieval system, or otherwise, without the prior written permission of SANYO Electric Co., Ltd.
- Any and all information described or contained herein are subject to change without notice due to product/technology improvement, etc. When designing equipment, refer to the "Delivery Specification" for the SANYO product that you intend to use.
- Information (including circuit diagrams and circuit parameters) herein is for example only ; it is not guaranteed for volume production. SANYO believes information herein is accurate and reliable, but no guarantees are made or implied regarding its use or any infringements of intellectual property rights or other rights of third parties.