

SANYO	No. 4528A	Monolithic Digital IC
		LB1643
Forward/Reverse Motor Driver with Brake		

OVERVIEW

The LB1643 is a forward/reverse motor driver IC. The direction and brake functions are controlled from a single input, and the output voltages can be set by resistors. Further, the output voltage has 3 modes, full, HIGH-level and LOW-level voltage modes. The output voltage can be controlled from a single input and a microcontroller interface.

FEATURES

- Single-input forward, reverse and brake functions
- Output voltage can be set using resistors
- Single-input full-drive, HIGH-level drive and LOW-level drive select function
- Microcontroller interface
- Built-in surge-current absorption components
- Built-in reference voltage circuit
- Built-in thermal protection circuit

PIN ASSIGNMENT

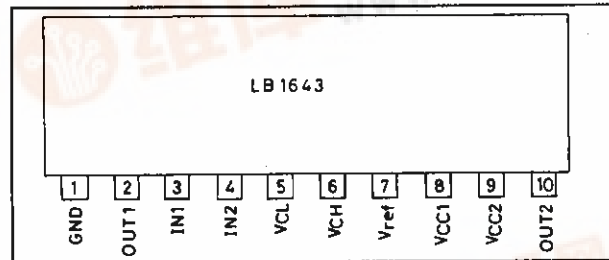

PACKAGE DIMENSIONS

Unit: mm

3043A

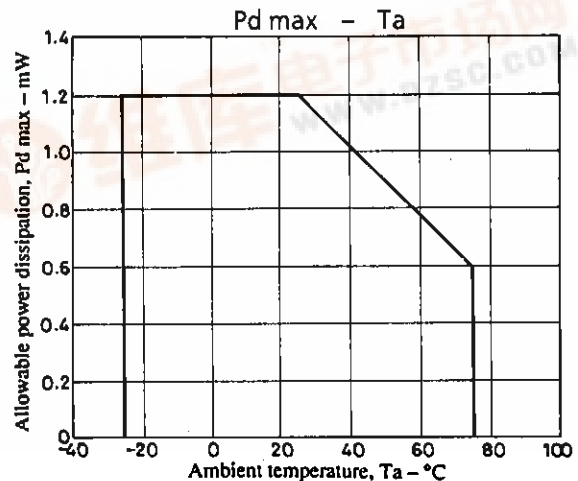
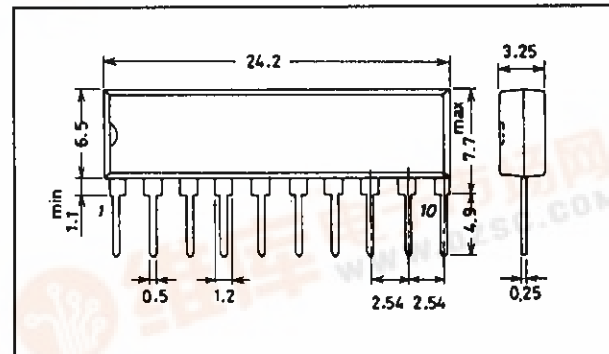

BLOCK DIAGRAM

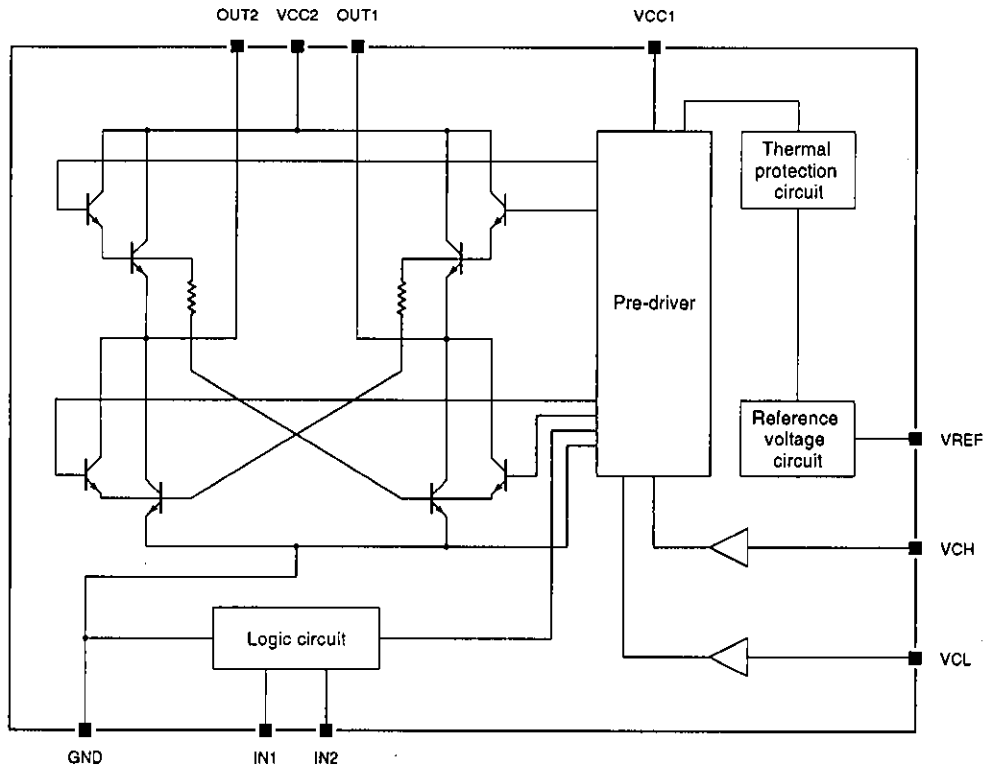

PIN DESCRIPTION

Number	Name	Equivalent circuit	Description
1	GND		Power and signal ground
3	IN1		Output voltage control input terminal $V_M \cong 2.5\text{ V}$ when input is open.
4	IN2		Forward, reverse and brake control input terminal $V_M \cong 2.5\text{ V}$ when input is open.
5	VCL		Output voltage set terminal

Unit (resistance: Ω)

LB1643

Number	Name	Equivalent circuit	Description
6	V_{CH}		Output voltage set terminal
7	V_{ref}		Reference voltage output. $V_{ref} = 6.35\text{ V}$
8	V_{CC1}		Signal voltage supply
9	V_{CC2}		Power voltage supply
2	OUT1		Motor coil connection terminals
10	OUT2		

Unit (resistance: Ω)

SPECIFICATIONS

Absolute Maximum Ratings

$T_a = 25\text{ }^\circ\text{C}$

Parameter	Symbol	Condition	Rating	Unit
Supply voltage	$V_{CC\text{ max}}$		18	V
Input voltage range	V_{IN}	$V_{CC} > V_{IN}$	-0.3 to +6	V
Output current	I_{OUT}		± 1.6	A
Power dissipation	$P_d\text{ max}$		1.2	W
Operating temperature range	T_{opr}		-25 to +75	$^\circ\text{C}$
Storage temperature range	T_{stg}		-55 to +125	$^\circ\text{C}$

Recommended Operating Conditions

$T_a = 25\text{ }^\circ\text{C}$

Parameter	Symbol	Condition	Rating	Unit
Supply voltage ranges	V_{CC1}		8.0 to 18	V
	V_{CC2}	$V_{CC1} \geq V_{CC2}$	5 to 18	V
Forward-reverse direction prohibit time	t_{OFF}		≥ 20	μs

LB1643

Electrical Characteristics

$T_a = 25\text{ }^\circ\text{C}$, $V_{CC} = 12\text{ V}$

Parameter	Symbol	Condition	Rating			Unit
			min	typ	max	
LOW-level input voltage	V_{INL}		0	–	1.0	V
HIGH-level input voltage	V_{INH}		4.2	–	6.0	V
MID-level input voltage	V_{INM}		2.0	–	3.0	V
Input impedance	Z_{IN}		–	75	–	k Ω
Current consumption	I_{CC}		–	5.5	10	mA
Output voltages	V_{OUT1}	$R_L = 60\ \Omega$, $V_{CH} = 2.5\text{ V}$, $V_{IN1} = 2.5\text{ V}$, $V_{IN2} = 0\text{ V}$	4.4	4.95	5.4	V
	V_{OUT2}	$R_L = 60\ \Omega$, $V_{CH} = 2.5\text{ V}$, $V_{IN1} = 2.5\text{ V}$, $V_{IN2} = 5.0\text{ V}$	4.4	4.95	5.4	V
Output leakage current	I_{OL}	$R_L = \infty$	–	0.01	1.0	mA
Saturation voltages (upper)	V_{sat11}	$V_{CC} = 12\text{ V}$, $I_{OUT} = 300\text{ mA}$	–	1.9	2.2	V
	V_{sat12}	$V_{CC} = 12\text{ V}$, $I_{OUT} = 500\text{ mA}$	–	1.9	2.3	V
Saturation voltages (lower)	V_{sat21}	$V_{CC} = 12\text{ V}$, $I_{OUT} = 300\text{ mA}$	–	0.25	0.5	V
	V_{sat22}	$V_{CC} = 12\text{ V}$, $I_{OUT} = 500\text{ mA}$	–	0.4	0.65	V
Reference voltage	V_{ref}		6.0	6.35	6.8	V
Reference voltage load characteristics	$\frac{\Delta V_{ref}}{\Delta I_{ref}}$	$I_{ref} = -2.0\text{ to }0\text{ mA}$	–	0.05	0.1	V/mA
Control to output gain	$\frac{V_{OUT}/V_{CH}}{V_{OUT}/V_{CL}}$	$V_{CH} = 2.5\text{ V}$, $V_{CL} = 2.5\text{ V}$, $R_L = 60\ \Omega$	1.5	1.90	2.4	–
Thermal shutdown temperature	T_{SD}	See note.	150	180	–	$^\circ\text{C}$

Note

Design value only (not measured).

TYPICAL APPLICATION

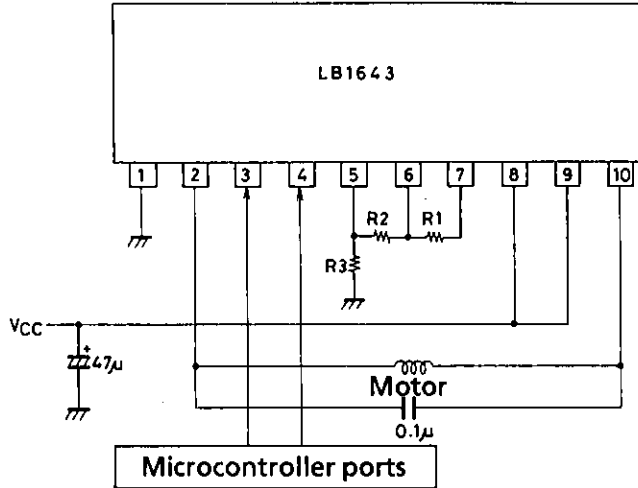

Unit (Capacitance : F)

Notes

1. Use a microcontroller with CMOS output ports for HIGH-level, LOW-level and open-circuit conditions.
2. It is recommended that R1, R2 and R3 total approximately 60 kΩ.
3. The input voltage for IN1 and IN2 should be 0 to 6 V to ensure the output voltage does not cause incorrect operation. Furthermore, IN1 and IN2 voltages should not be applied if the V_{CC} supply is not applied.
4. To avoid occurrences where both the upper and lower transistors are ON simultaneously, make sure IN1 or IN2 is open for a period of tens of ms before switching control to the opposite device.
5. Connect a 20 µF or larger capacitor between V_{CC} and GND.
6. A large current of several hundred mA flows in the motor circuits when the motor is being driven. Accordingly, the output current line and the input circuit should be wired so that they do not have a common impedance.

LOGIC TABLE

Input		Output voltage		Operation
IN1	IN2	OUT1	OUT2	
HIGH	HIGH	LOW	FULL	Forward (reverse)
MID	HIGH	LOW	2V _{CH}	
LOW	HIGH	LOW	2V _{CL}	
HIGH	MID	OFF	OFF	Brake
MID	MID	OFF	OFF	
LOW	MID	OFF	OFF	
HIGH	LOW	FULL	LOW	Reverse (forward)
MID	LOW	2V _{CH}	LOW	
LOW	LOW	2V _{CL}	LOW	

Input levels are

- V_H ≥ 4.2 V
- V_M = 2.0 to 3.0 V
- V_L ≤ 1.0 V

When IN1 and IN2 are open, they take on a voltage of 2.5 V.

- No products described or contained herein are intended for use in surgical implants, life-support systems, aerospace equipment, nuclear power control systems, vehicles, disaster/crime-prevention equipment and the like, the failure of which may directly or indirectly cause injury, death or property loss.
- Anyone purchasing any products described or contained herein for an above-mentioned use shall:
 - ① Accept full responsibility and indemnify and defend SANYO ELECTRIC CO., LTD., its affiliates, subsidiaries and distributors and all their officers and employees, jointly and severally, against any and all claims and litigation and all damages, cost and expenses associated with such use:
 - ② Not impose any responsibility for any fault or negligence which may be cited in any such claim or litigation on SANYO ELECTRIC CO., LTD., its affiliates, subsidiaries and distributors or any of their officers and employees jointly or severally.
- Information (including circuit diagrams and circuit parameters) herein is for example only; it is not guaranteed for volume production. SANYO believes information herein is accurate and reliable, but no guarantees are made or implied regarding its use or any infringements of intellectual property rights or other rights of third parties.