

SANYO

Dual Bidirectional Motor Driver

Overview

The LB1651 is a dual bidirectional motor driver that is designed to drive motors directly by TTL outputs. It provides the functions of bidirectional motor drive, brake that are determined by two inputs and the inhibit function that brings the output to a high impedance state.

Applications

- Multi DC motor driver
- Bidirectional motor driver
- Bipolar stepping motor driver

Features

- High output current (1 A/ch)
- Wide operating voltage range (4.5 to 36 V)
- Inhibit function
- Direct drive made possible by TTL, CMOS IC
- High noise margin

Specifications

Absolute Maximum Ratings at Ta = 25°C

Parameter	Symbol	Conditions	Ratings	Unit
Maximum supply voltage	V _{CC1}		36	V
Logic supply voltage	V _{CC2}		36	V
Input voltage	V _{IN}		7	V
Inhibit voltage	V _{INH}		7	V
Peak output current	I _{OUT}	1 ms non-repetitive	2	A
Allowable power dissipation	P _{d max}		3	W
Operating temperature	T _{opr}		-20 to +80	°C
Storage temperature	T _{stg}		-40 to +150	°C

Allowable Operating Conditions at Ta = 25°C

Parameter	Symbol	Conditions	Rating	Unit
Supply voltage	V _{CC1}		4.5 to 36	V
Logic supply voltage	V _{CC2}		4.5 to 36	V

Package Dimensions

unit : mm

3037A-DIP20H

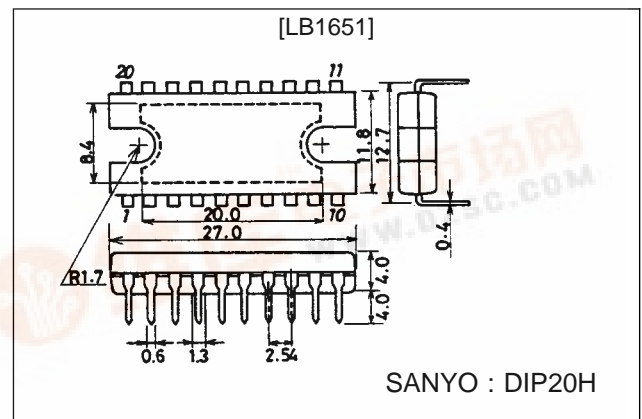

LB1651

Electrical Characteristics at $T_a = 25^\circ\text{C}$, $V_{CC1} = 24\text{ V}$, $V_{CC2} = 5\text{ V}$

Parameter	Symbol	Conditions	min	typ	max	Unit
Supply current (Per channel)	I_{CC1}	$V_{IN} = L, I_O = 0, V_{inh} = H$			1.5	mA
		$V_{IN} = H, I_O = 0, V_{inh} = H$			6	mA
		$V_{inh} = L$			1	mA
Logic supply current	I_{CC2}	$V_{IN} = L, I_O = 0, V_{inh} = H$		44	60	mA
		$V_{IN} = H, I_O = 0, V_{inh} = H$			22	mA
		$V_{inh} = L$			24	mA
Low-level input voltage	V_{IL}		-0.3		+1.5	V
High-level Input Voltage	V_{IH}	$V_{CC2} \leq 7\text{ V}$	2.3		V_{CC2}	V
		$V_{CC2} > 7\text{ V}$	2.3		7	V
Low-level input current	I_{IL}	$V_{IN} = L$			± 10	μA
High-level input current	I_{IH}	$V_{IN} = H - 0.3\text{ V}$		30	100	μA
Low-level inhibit voltage	V_{inhL}		-0.3		+1.5	V
High-level inhibit voltage	V_{inhH}	$V_{CC2} \leq 7\text{ V}$	2.3		V_{CC2}	V
		$V_{CC2} > 7\text{ V}$	2.3		7	V
Low-level inhibit current	I_{inhL}		-100	-30		μA
High-level inhibit current	I_{inhH}				± 10	μA
Saturation voltage	$V_{CE(sat)H}$	$I_O = -1\text{ A}$		1.4	1.8	V
	$V_{CE(sat)L}$	$I_O = 1\text{ A}$		1.2	1.8	V
Sensing voltage	V_{SENS}				2	V

Pin Assignment

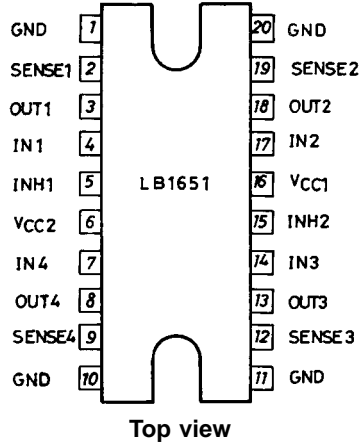

Truth Table

V_{IN} (per CH)	V_{inh}	V_O
H	H	H
L	H	L
H	L	Open*
L	L	Open*

*: High impedance

LB1651

Sample Application Circuit

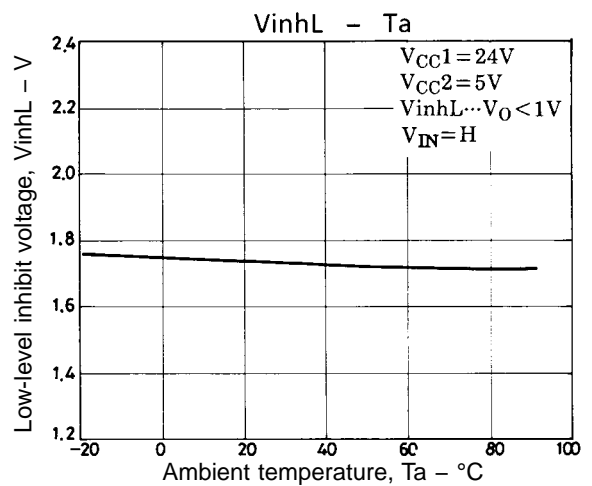
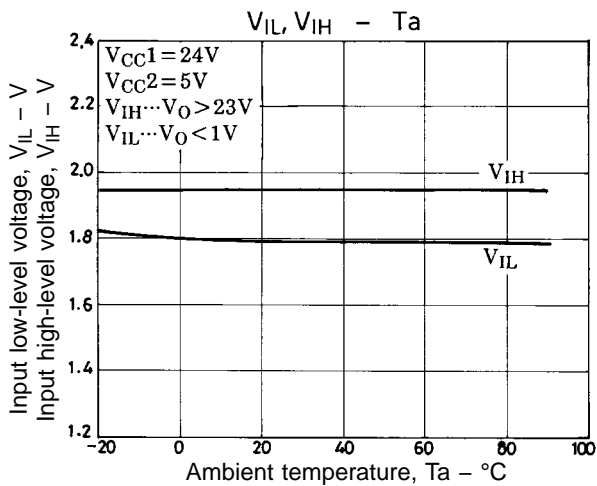
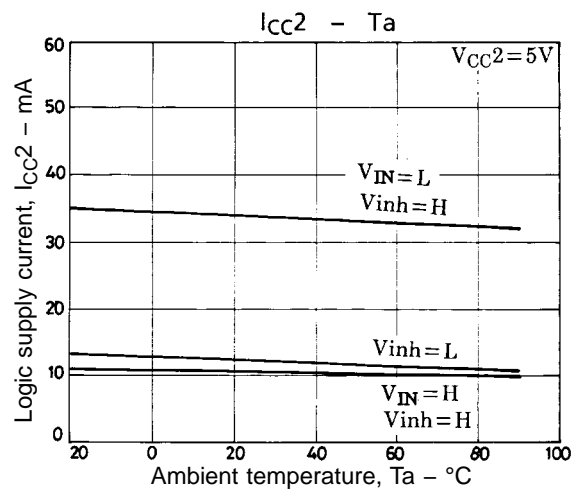
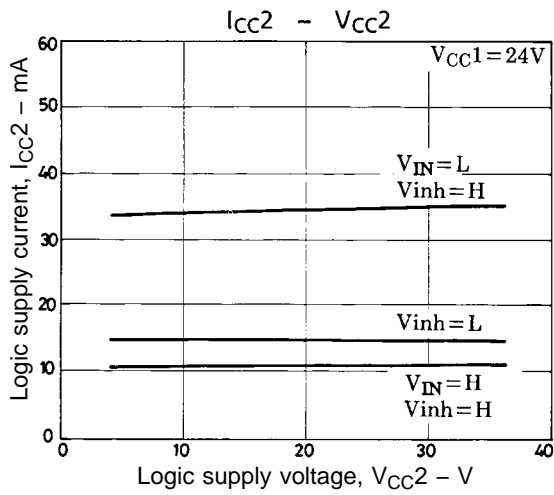
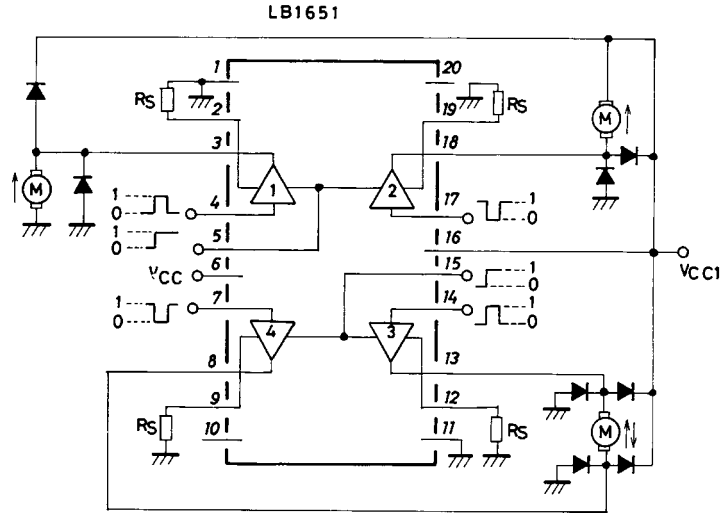

LB1651

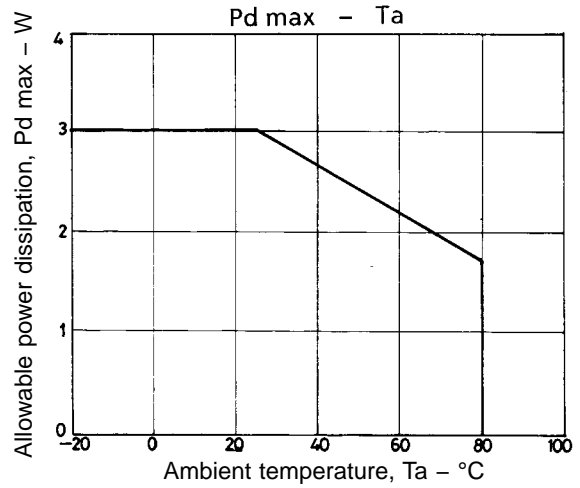
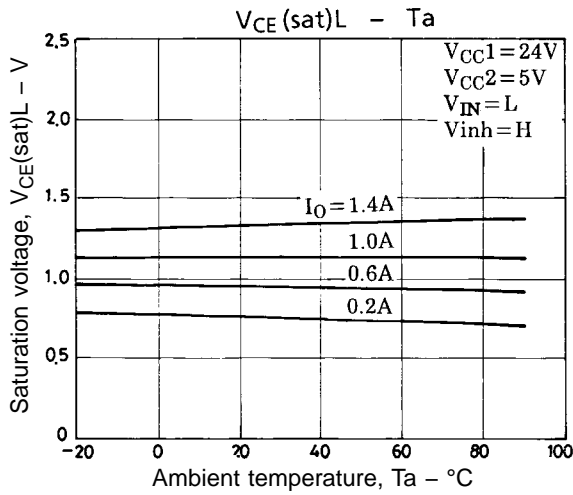
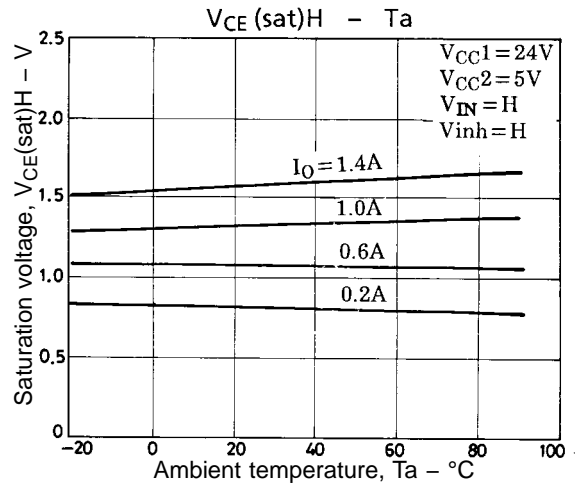
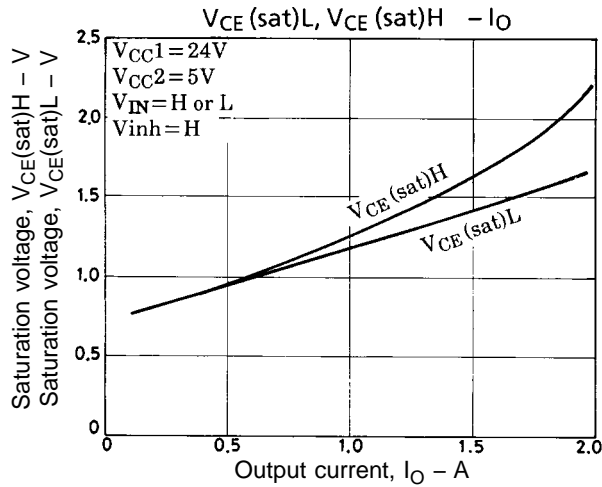

- No products described or contained herein are intended for use in surgical implants, life-support systems, aerospace equipment, nuclear power control systems, vehicles, disaster/crime-prevention equipment and the like, the failure of which may directly or indirectly cause injury, death or property loss.
- Anyone purchasing any products described or contained herein for an above-mentioned use shall:
 - ① Accept full responsibility and indemnify and defend SANYO ELECTRIC CO., LTD., its affiliates, subsidiaries and distributors and all their officers and employees, jointly and severally, against any and all claims and litigation and all damages, cost and expenses associated with such use:
 - ② Not impose any responsibility for any fault or negligence which may be cited in any such claim or litigation on SANYO ELECTRIC CO., LTD., its affiliates, subsidiaries and distributors or any of their officers and employees jointly or severally.
- Information (including circuit diagrams and circuit parameters) herein is for example only; it is not guaranteed for volume production. SANYO believes information herein is accurate and reliable, but no guarantees are made or implied regarding its use or any infringements of intellectual property rights or other rights of third parties.