

SANYO

2-Phase Unipolar Brushless Motor Driver

Overview

The LB1669, 1669M are 2-phase unipolar brushless motor drivers. They make it possible to configure motor lock protection and automatic recovery circuits with few external components.

Features and Functions

- Hall element direct connection possible
- Output transistor with 1.5 A output current built in
- Rotation detect function (Drive mode: "L", Stop mode: "H") built in
- Motor lock protection and automatic recovery functions built in
- Thermal shutdown circuit built in
- DIP-10S and MFP-10S packages mean small mounting surfaces.
- Pin compatible with LB1663, so can replace 12 V types.

Package Dimensions

unit : mm

3098A-DIP10S

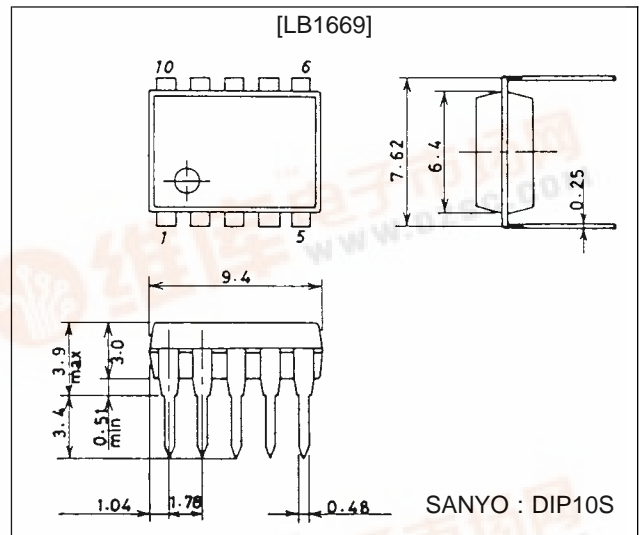

unit : mm

3086A-MFP10S

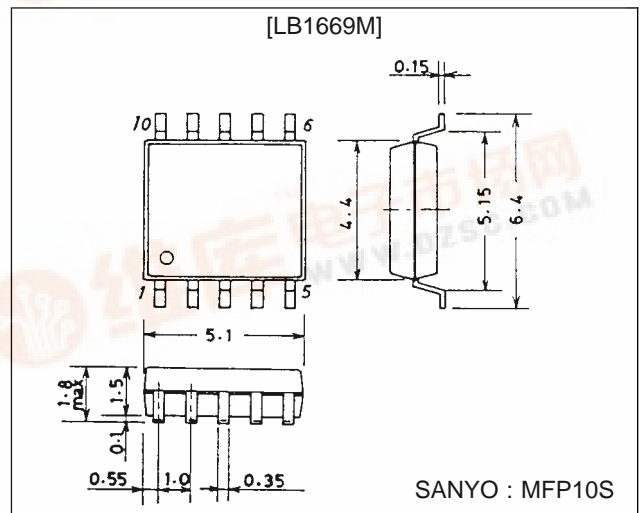

LB1669, 1669M

Specifications

Absolute Maximum Ratings at $T_a = 25\text{ }^\circ\text{C}$

Parameter	Symbol	Conditions	Ratings	Unit
Maximum input current	$I_{CC\text{ max}}$	$t \leq 20\text{ ms}$	200	mA
Output applied voltage	V_{OUT}		-0.3 to +60	V
Output current	I_{OUT}		1.5	A
RD flow-in current	I_{RD}		10	mA
RD applied voltage	V_{RD}		30	V
Allowable power dissipation	$P_d\text{ max}$	LB1669: Independent IC	1.2	W
		LB 1669M: Mounted on $20 \times 15 \times 1.5\text{ mm}^3$ glass epoxy board	800	mW
Operating temperature	T_{opr}		-30 to +80	$^\circ\text{C}$
Storage temperature	T_{stg}		-55 to +125	$^\circ\text{C}$

Allowable Operating Conditions at $T_a = 25\text{ }^\circ\text{C}$

Parameter	Symbol	Conditions	Ratings	Unit
Input current range	I_{CC}		6.0 to 50	mA
Common-mode input voltage range	V_{ICM}		0 to $V_{IN}-1.5$	V

Electrical Characteristics at $T_a = 25\text{ }^\circ\text{C}$, $I_{CC} = 10\text{ mA}$

Parameter	Symbol	Conditions	min	typ	max	Unit
Output withstand voltage 1	V_{OR}		60			V
Output withstand voltage 2	$V_{O(sus)}$	$I_O = 0.1\text{ A}$	40			V
Output saturation voltage	$V_{O\text{ sat}1}$	$I_O = 0.5\text{ A}$		0.95	1.2	V
	$V_{O\text{ sat}2}$	$I_O = 1.0\text{ A}$		1.15	1.5	V
V_{IN} voltage	V_{IN}	$I_{CC} = 7.0\text{ mA}$	6.4	6.7	7.0	V
Amp input offset voltage	V_{OFF}		-7	0	7.0	mV
Amp input bias current	I_{BA}		-250			nA
RD output saturation voltage	$V_{RD(sat)}$	$I_{RD} = 5\text{ mA}$		0.1	0.2	V
C flow-out current	I_{C1}		2.1	3	3.9	μA
C discharge current	I_{C2}		0.31	0.44	0.59	μA
Comparator input threshold voltage	V_{TH1}		0.77	$0.8V_{IN}$	0.83	V
	V_{TH2}		0.42	$0.45V_{IN}$	0.48	V

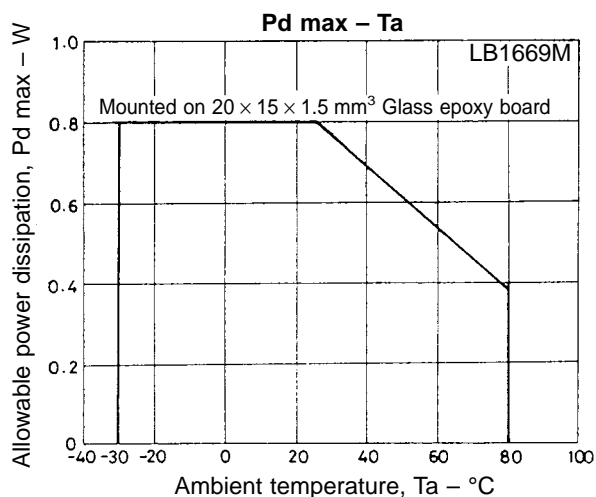
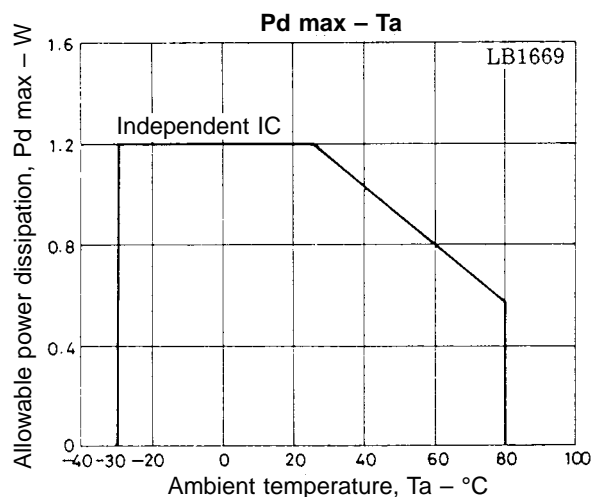

LB1669, 1669M

Pin Assignments

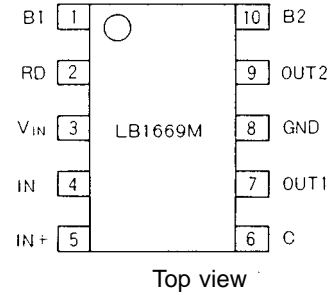
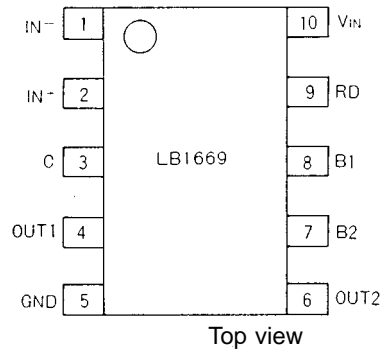

Equivalent Circuit Block Diagram and Sample Application Circuit 1

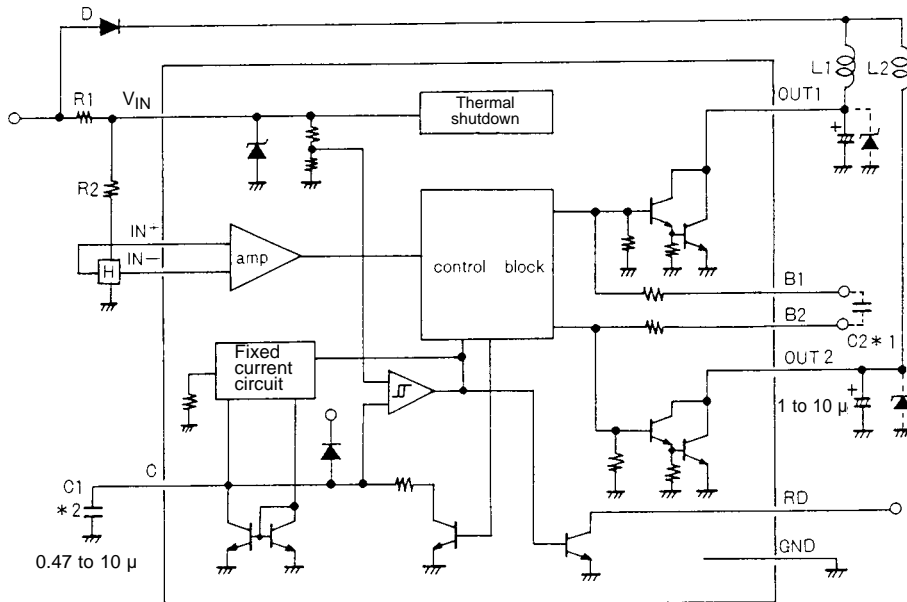

Note * 1: If radio noise is a problem, 0.01 to 0.1 μ F
 * 2: Use a low-leak capacitor.

Unit (capacitance: F)

Sample Application Circuit 2

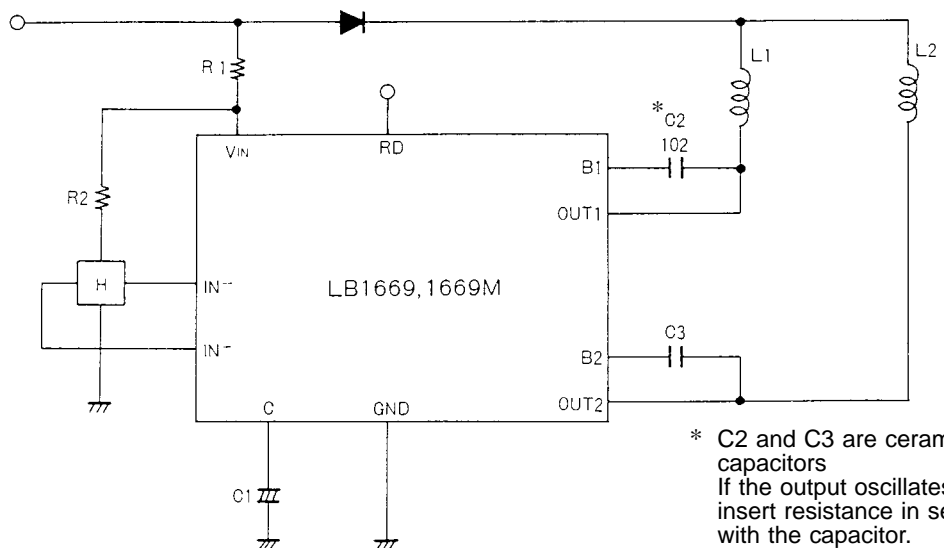

* C2 and C3 are ceramic capacitors
 If the output oscillates, insert resistance in series with the capacitor.

LB1669, 1669M

Sample Application Circuit 2 Output Waveform Diagram

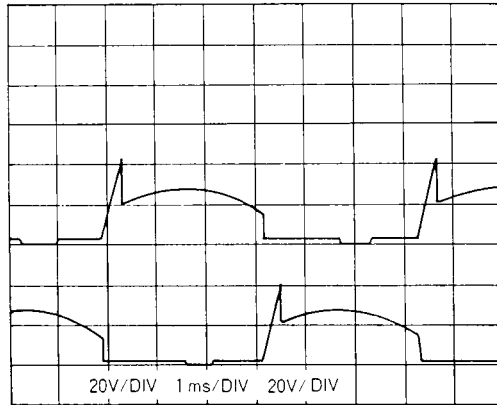

Truth Table

IN+	IN-	C	OUT1	OUT2
H	L	L	H	L
L	H	L	L	H
H	L	H	H	H
L	H	H	H	H

Design Notes (See Sample Application Circuits.)

(1) Supply Voltage (V_{IN} pin)

The LB1669 series have the internal parallel regulator which supplies power to the Hall amplifier circuit and the control block. Therefore, the driver ICs are not affected by power source fluctuations and kickbacks from the motor. They maintain the stable operations even if noise signals such as surge are generated.

Set the resistance R1 between V_{CC} and V_{IN} so that the I_{CC} current of 6 mA to 50 mA can flow into the V_{IN} pin within the supply voltage range of a fan motor.

V_{IN} is 6.7 V typ at $I_{CC} = 7$ mA.

The current flowing into V_{IN} is calculated using the equation shown below.

$$I_{CC} = \frac{V_{CC} - V_{IN}}{R1} \dots \dots \dots (1)$$

- Consideration given to surge voltage

The maximum allowable current at V_{IN} pin is 200 mA, so the withstand voltage level is designed as follows.

$$V_{surge} = V_{IN} + R1 \times 200 \text{ mA} \dots \dots \dots (2)$$

(2) Hall input pin voltage (IN- and IN+ pins)

IN- and IN+ are input pins for the Hall element output. Set the Hall element output voltage to within the range of 0 V to $V_{IN} - 1.5$ V.

The gain between the Hall input pin and the output pin is 100 dB or greater. The offset voltage of the Hall input amplifier is ± 7 mV therefore, the Hall element output must be set with the offset voltage (± 7 mV) considered.

(3) Output transistors (OUT1 and OUT2 pins)

Output current $I_O = 1.5$ A max.

Output saturation voltage $V_O \text{ sat} = 1.15$ V/1.0 A (typ.)

The LB1669 requires one of the three types of output protection.

- ① When external capacitors are connected between OUT and GND, the capacitance should not exceed 10 μ F. Use capacitance that will hold kickback voltage and back voltage to 60 V or less.
- ② When external Zener diodes are connected, use one that will have a cutoff voltage of 40 V or less. If radio noise is a problem, insert a capacitor of 0.01 to 0.1 μ F between B1 and B2.
- ③ When external capacitors are connected between OUT and B, use one that will hold kickback voltage to 40 V or less. If it oscillates, insert resistance in series with the capacitor.

LB1669, 1669M

(4) Output protection function (C pin)

Capacitor pin used in forming an automatic recovery circuit. If rotation is stopped due to overload, the pin voltage level increases and then forces the output to become inactive. In this case, after proper load adjustment, the output returns to the 'drive' mode from the 'stop' mode automatically. By changing the capacitor value, the lock detect time period can be set.

For 1 μF lock detection time about 2 seconds
 lock protection time (output ON) about 1 second
 (output OFF) about 6 seconds

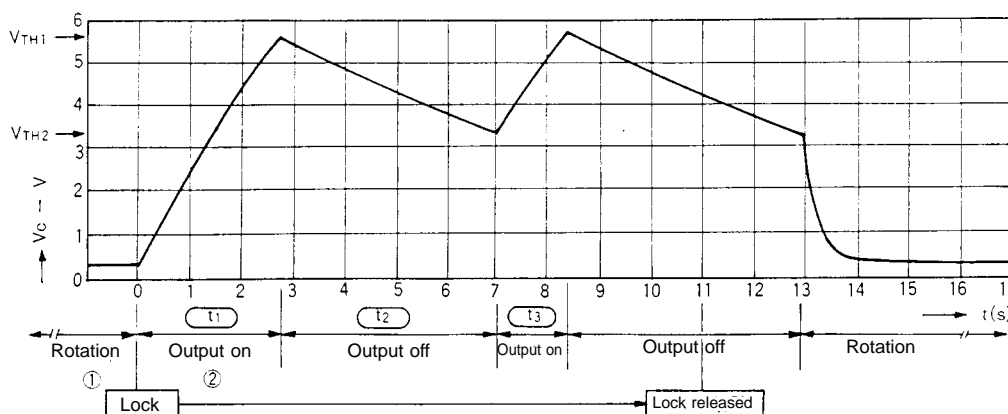

Automatic Recovery Circuit C Pin Voltage

- ① When a fan is rotating, the capacitor is charged at 3 μA (typ) and discharged through the C with pulses according to the rotational speed.
- ② When a fan is locked, no discharge occurs through the C and the C voltage rises, turning OFF the output at $0.8 \times V_{IN}$.
- ③ When the output is turned OFF, discharge occurs through the C at 0.44 μA (typ). If the lock is not released when the C voltage drops to V_{TH2} , the capacitor is charged to V_{TH1} again. (At this moment, the output is turned ON.) These operations ② and ③ are repeated at a cycle of approximately $t_{on} : t_{off} = 1 : 6$ to protect the motor.
- ④ If the lock is released when the C voltage drops to V_{TH2} , the output is turned ON, starting rotation.

(5) Rotation detect signal (RD pin)

Open collector output (Drive mode: "L", Stop mode: "H")

(6) Radio noise reducing (pins B1 and B2)

These are the base pins for Darlington connected output transistors.
 If radio noise is a problem, add a capacitor of 0.01 to 0.1 μF or less.

(7) Thermal shutdown function

Shutdown the driver output in case of coil short-circuiting and abnormal IC heating.

- No products described or contained herein are intended for use in surgical implants, life-support systems, aerospace equipment, nuclear power control systems, vehicles, disaster/crime-prevention equipment and the like, the failure of which may directly or indirectly cause injury, death or property loss.
- Anyone purchasing any products described or contained herein for an above-mentioned use shall:
 - ① Accept full responsibility and indemnify and defend SANYO ELECTRIC CO., LTD., its affiliates, subsidiaries and distributors and all their officers and employees, jointly and severally, against any and all claims and litigation and all damages, cost and expenses associated with such use;
 - ② Not impose any responsibility for any fault or negligence which may be cited in any such claim or litigation on SANYO ELECTRIC CO., LTD., its affiliates, subsidiaries and distributors or any of their officers and employees jointly or severally.
- Information (including circuit diagrams and circuit parameters) herein is for example only; it is not guaranteed for volume production. SANYO believes information herein is accurate and reliable, but no guarantees are made or implied regarding its use or any infringements of intellectual property rights or other rights of third parties.