

SANYO	No.3345	Monolithic Digital IC
		LB1687
3-Phase Brushless Motor Driver		

Applications

The LB1687 is a 3-phase brushless motor driver IC ideally suited for use in VTR capstan motor, drum motor drive applications.

Features and Functions

- (1) 120° voltage linear type
- (2) Soft switching type eliminating noises caused by current switching and making the values of external capacitors smaller (comparable to those of chip capacitors)
- (3) On-chip FG amplifier
- (4) On-chip thermal shutdown circuit
- (5) The FG signal can be used to detect the rotational speed of a motor so that the hall amp gain is changed in two steps, thus reducing torque ripple and noise.
- (6) Motor drivable at voltage down to motor supply voltage 5V

Absolute Maximum Ratings at Ta = 25°C

			unit
Maximum Supply Voltage	V _{CC} max1	20	V
	V _{CC} max2	7.0	V
Output Supply Voltage	V _{OUT.V.W.}	22	V
Output Current	I _{OUT}	1.5	A
Allowable Power Dissipation	P _d max	2.1	W
Operating Temperature	T _{opr}	-20 to +75	°C
Storage Temperature	T _{stg}	-55 to +125	°C

Allowable Operating Conditions at Ta = 25°C

			unit
Supply Voltage	V _{CC1}	5 to 18	V
	V _{CC2}	4.3 to 6.5	V

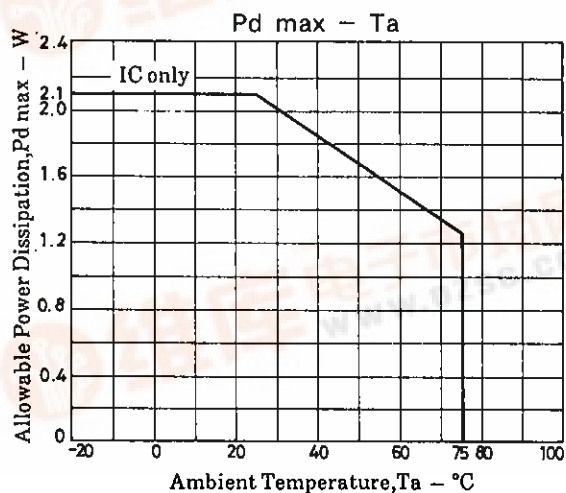

Package Dimensions 3061

(unit: mm)

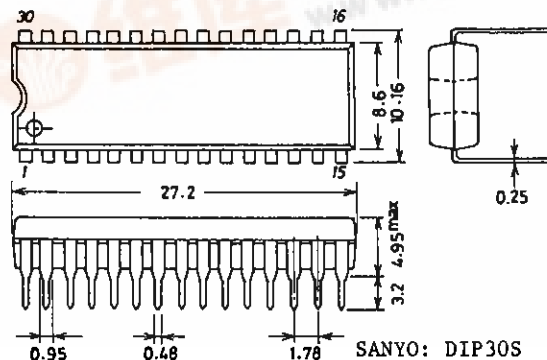

LB1687

Electrical Characteristics at Ta = 25°C, VCC1 = 12V, VCC2 = 5V				min	typ	max	unit
[Power Supply]							
Supply Current 1	ICC1	VC = 0, RL = ∞		17	30		mA
Supply Current 2	ICC2	VC = 0		6.5	9.5		mA
[Output]							
Output Saturation Voltage	VO(sat)1	IOUT = 0.5A, sink + source		1.6	2.2		V
	VO(sat)2	IOUT = 1.0A, sink + source		2.0	3.0		V
Output TRS Voltage	VO(sus)	IOUT = 20mA (See note.)	20				V
Output Quiescent Voltage	VOQ	VC = 0	5.8	6.1	6.4		V
[Hall Input-Output]							
Hall Amp Input Offset Voltage	VH offset		-5		+5		mV
Hall Amp Input Bias Current	IH bias			1	5		μA
Hall Amp Common-Mode	VH ch		1.3		3.7		V
Input Voltage Range							
Hall Input-Output Voltage Gain	GVHO1			56			dB
	GVHO2			43			dB
[Control-Output]							
Control-Output Drive Gain	GVCO		38	41	44		dB
Control-Output CH Difference	ΔGVCO		-2		+2		dB
[FG Amplifier]							
FG Amp Input Offset Voltage	VFG offset		-8		+8		mV
Open-Loop Voltage Gain	GvFG	f = 1kHz		60			dB
Source Output Saturation Voltage	VFG OU	IO = 2mA	3.7				V
Sink Output Saturation Voltage	VFG OD	IO = -2mA			1.3		V
Common-Mode Signal	CHR	(See note.)		80			dB
Rejection Ratio							
FG Amp Common-Mode	VFG CH		0		3.5		V
Input Voltage Range							
Phase Margin		(See note.)		20			deg.
[Motor Detection]							
Motor Detection Amp			35	50	65		mV
Hysteresis Width							
CR Pin Threshold Voltage		VCR changes from LOW to HIGH.	2.35	2.5	2.65		V
Thermal Shutdown Temperature	TSD	(See note.)	150	180	210		°C
Thermal Shutdown Hysteresis	ΔTSD	(See note.)		15			°C

Note : Values shown are design targets only. No measurements have been taken.

Pin Assignment

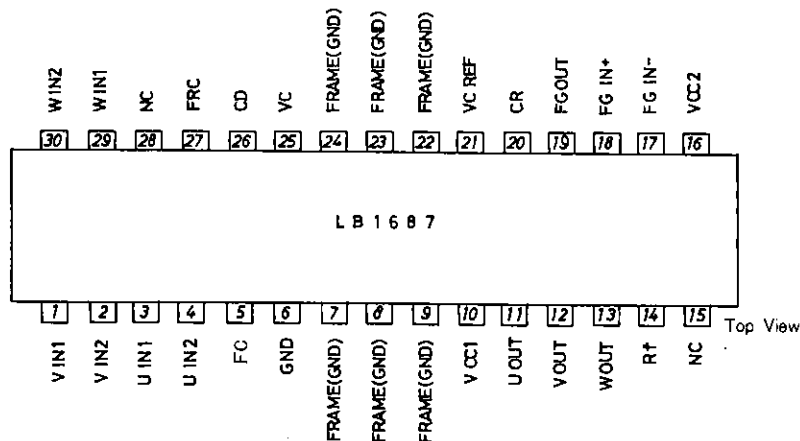

LB1687

Equivalent Circuit Block Diagram

Unit (resistance: Ω , capacitance: F)

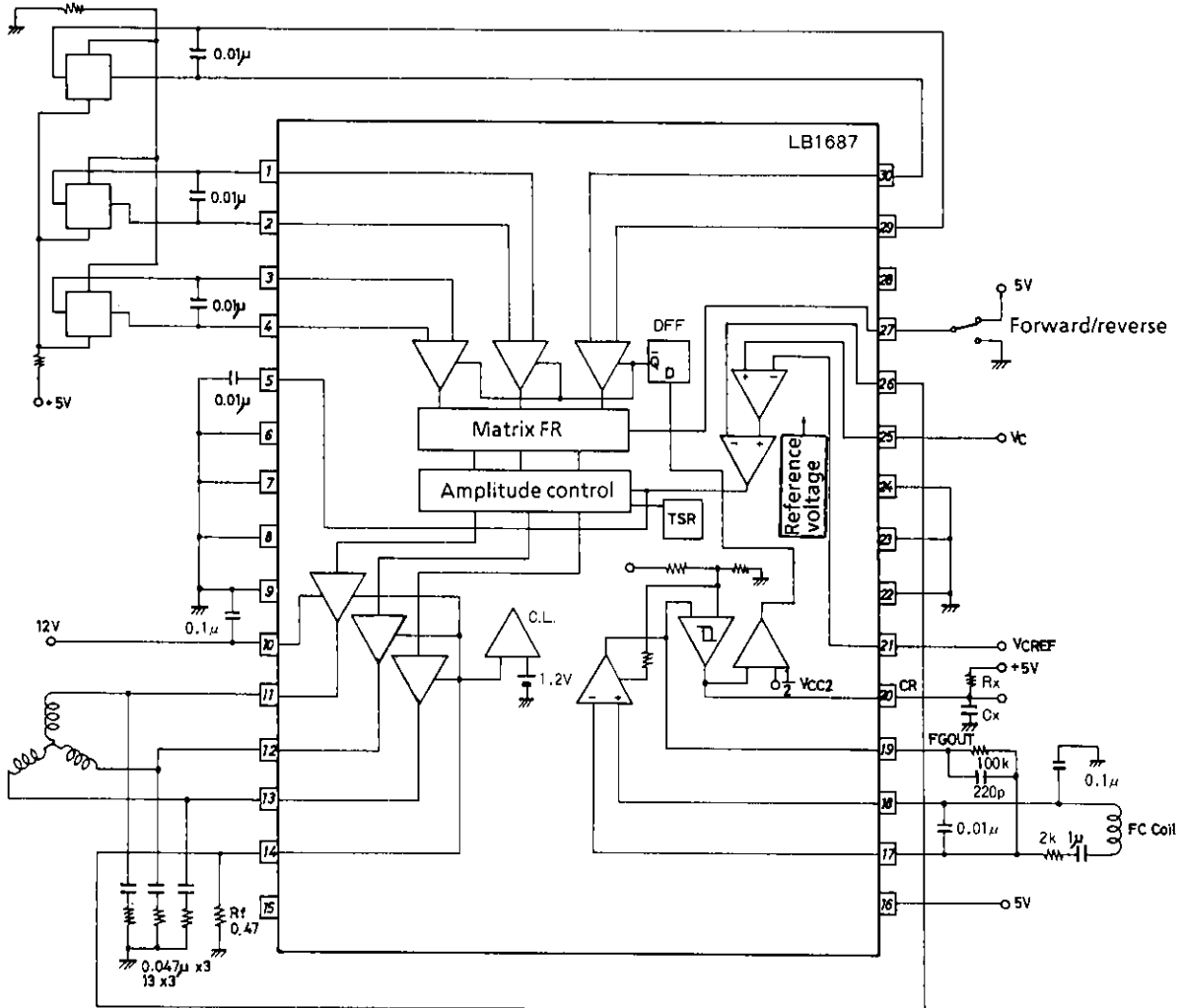

Truth Table

	Source	Sink	Input			Forward/Reverse Control
			U	V	W	F/R/C
1	W phase → V phase		H	H	L	L
	V phase → W phase		H	H	L	H
2	W phase → U phase		H	L	L	L
	U phase → W phase		H	L	L	H
3	V phase → W phase		L	L	H	L
	W phase → V phase		L	L	H	H
4	U phase → V phase		L	H	L	L
	V phase → U phase		L	H	L	H
5	V phase → U phase		H	L	H	L
	U phase → V phase		H	L	H	H
6	U phase → W phase		L	H	H	L
	W phase → U phase		L	H	H	H

Input:

H: High level. One of the inputs should have a potential at least 0.2V higher than the other.

L: Low level. One of the inputs should have a potential at least 0.2V lower than the other.

Forward/reverse control:

H: 2.0 to V_{CC2}

L: 0 to 0.3V

- No products described or contained herein are intended for use in surgical implants, life-support systems, aerospace equipment, nuclear power control systems, vehicles, disaster/crime-prevention equipment and the like, the failure of which may directly or indirectly cause injury, death or property loss.
- Anyone purchasing any products described or contained herein for an above-mentioned use shall:
 - ① Accept full responsibility and indemnify and defend SANYO ELECTRIC CO., LTD., its affiliates, subsidiaries and distributors and all their officers and employees, jointly and severally, against any and all claims and litigation and all damages, cost and expenses associated with such use:
 - ② Not impose any responsibility for any fault or negligence which may be cited in any such claim or litigation on SANYO ELECTRIC CO., LTD., its affiliates, subsidiaries and distributors or any of their officers and employees jointly or severally.
- Information (including circuit diagrams and circuit parameters) herein is for example only; it is not guaranteed for volume production. SANYO believes information herein is accurate and reliable, but no guarantees are made or implied regarding its use or any infringements of intellectual property rights or other rights of third parties.