

SANYO	No.3347	Monolithic Digital IC
	LB1689D	
3-Phase Brushless Motor Driver		

Applications

The LB1689D is a 3-phase brushless motor driver IC ideally suited for use in VTR capstan motor, drum motor drive applications.

Features and Functions

- (1) 120° voltage linear type
- (2) Soft switching type eliminating noises caused by current switching and making the values of external capacitors smaller (comparable to those of chip capacitors)
- (3) On-chip FG amplifier
- (4) On-chip thermal shutdown circuit
- (5) The FG signal can be used to detect the rotational speed of a motor so that the hall amp gain is changed in two steps, thus reducing torque ripple and noise.

Absolute Maximum Ratings at Ta = 25°C

Parameter	Symbol	Value	unit
Maximum Supply Voltage	V _{CC max1}	20	V
	V _{CC max2}	7.0	V
Output Supply Voltage	V _{OUT.v.w.}	22	V
Output Current	I _{OUT}	1.5	A
Allowable Power Dissipation	P _{d max}	2.1	W
Operating Temperature	T _{opr}	-20 to +75	°C
Storage Temperature	T _{stg}	-55 to +125	°C

Allowable Operating Conditions at Ta = 25°C

Parameter	Symbol	Value	unit
Supply Voltage	V _{CC1}	8.5 to 18	V
	V _{CC2}	4.3 to 6.5	V

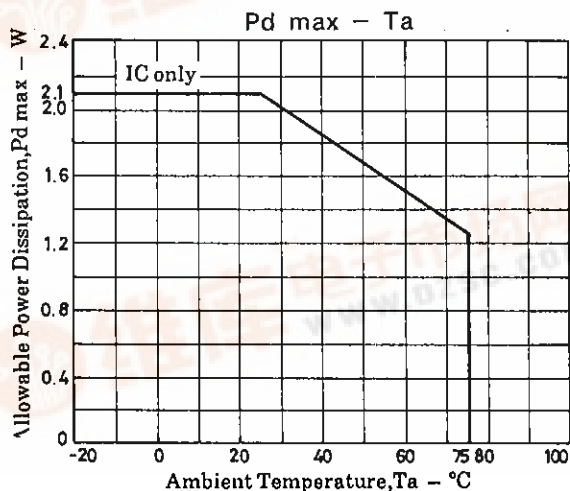

Package Dimensions 3061

(unit: mm)

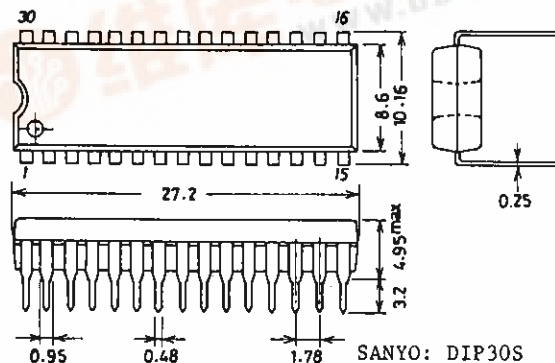

LB1689D

Electrical Characteristics at Ta = 25°C, V _{CC1} = 12V, V _{CC2} = 5V				min	typ	max	unit
[Power Supply]							
Supply Current 1	I _{CC1}	V _C = 0, R _L = ∞		17	30		mA
Supply Current 2	I _{CC2}	V _C = 0		6.5	9.5		mA
[Output]							
Output Saturation Voltage	V _{O(sat)1}	I _{OUT} = 0.5A, sink + source		1.6	2.2		V
	V _{O(sat)2}	I _{OUT} = 1.0A, sink + source		2.0	3.0		V
Output TRS Voltage	V _{O(sus)}	I _{OUT} = 20mA (See note.)	20				V
Output Quiescent Voltage	V _{OQ}	V _C = 0	5.8	6.1	6.4		V
[Hall Input-Output]							
Hall Amp Input Offset Voltage	V _H offset		-5		+5		mV
Hall Amp Input Bias Current	I _H bias			1	5		μA
Hall Amp Common-Mode	V _H ch		1.3		3.7		V
Input Voltage Range							
Hall Input-Output Voltage Gain	G _{VH01}			56			dB
	G _{VH02}			43			dB
[Control-Output]							
Control-Output Drive Gain	G _{VCO}		38	41	44		dB
Control-Output CH Difference	ΔG _{VCO}		-2		+2		dB
[FG Amplifier]							
FG Amp Input Offset Voltage	V _{FG} offset		-8		+8		mV
Open-Loop Voltage Gain	G _{VFG}	f = 1kHz		60			dB
Source Output Saturation Voltage	V _{FG OUT}	I _O = 2mA	3.7				V
Sink Output Saturation Voltage	V _{FG OD}	I _O = -2mA			1.3		V
Common-Mode Signal	CHR	(See note.)		80			dB
Rejection Ratio							
FG Amp Common-Mode	V _{FG CH}		0		3.5		V
Input Voltage Range							
Phase Margin		(See note.)		30			deg.
[Motor Detection]							
Motor Detection Amp			35	50	65		mV
Hysteresis Width							
CR Pin Threshold Voltage		V _{CR} changes from LOW to HIGH.	2.35	2.5	2.65		V
Thermal Shutdown Temperature	T _{SD}	(See note.)	150	180	210		°C
Thermal Shutdown Hysteresis	ΔT _{SD}	(See note.)		15			°C

Note : Values shown are design targets only. No measurements have been taken.

■ No products described or contained herein are intended for use in surgical implants, life-support systems, aerospace equipment, nuclear power control systems, vehicles, disaster/crime-prevention equipment and the like, the failure of which may directly or indirectly cause injury, death or property loss.

■ Anyone purchasing any products described or contained herein for an above-mentioned use shall:

- ① Accept full responsibility and indemnify and defend SANYO ELECTRIC CO., LTD., its affiliates, subsidiaries and distributors and all their officers and employees, jointly and severally, against any and all claims and litigation and all damages, cost and expenses associated with such use:
- ② Not impose any responsibility for any fault or negligence which may be cited in any such claim or litigation on SANYO ELECTRIC CO., LTD., its affiliates, subsidiaries and distributors or any of their officers and employees jointly or severally.

■ Information (including circuit diagrams and circuit parameters) herein is for example only; it is not guaranteed for volume production. SANYO believes information herein is accurate and reliable, but no guarantees are made or implied regarding its use or any infringements of intellectual property rights or other rights of third parties.

LB1689D

Equivalent Circuit Block Diagram

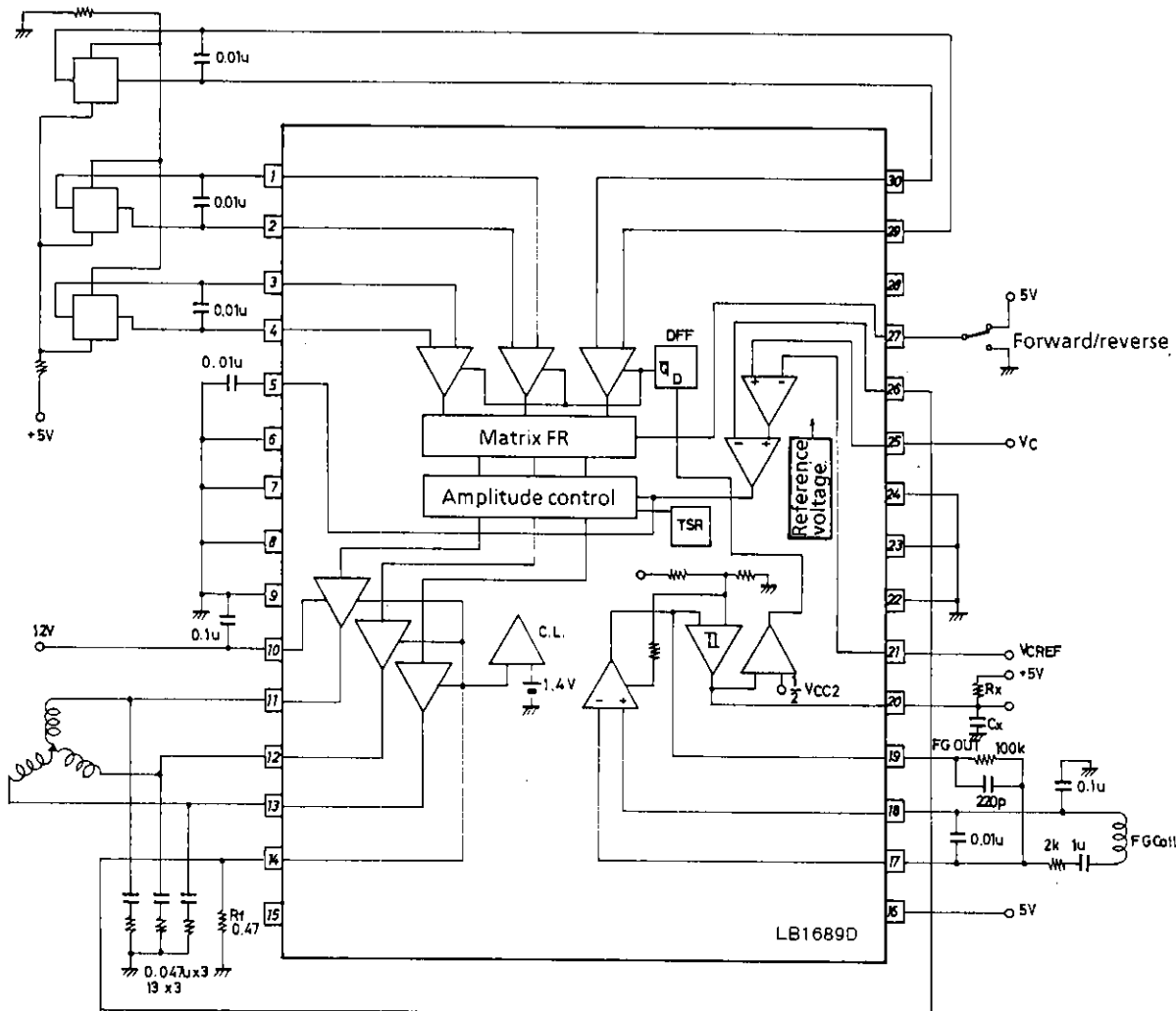

Unit (resistance: Ω , capacitance: F)

Pin Assignment

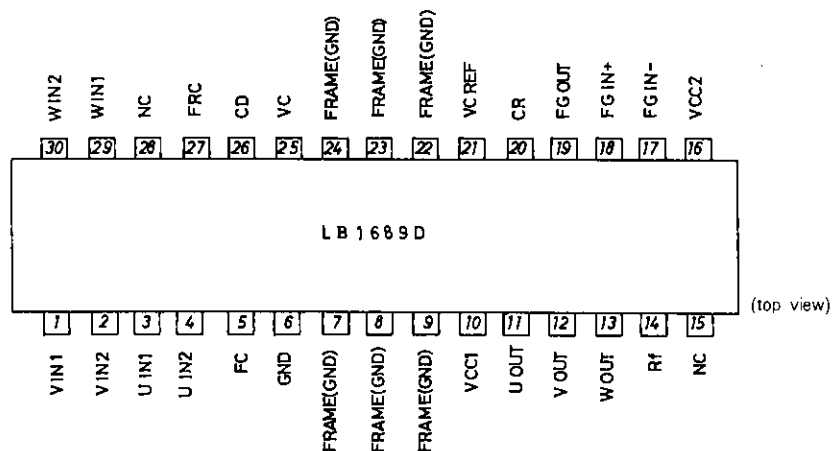

Note : All FRAME pins are connected to GND.

LB1689D

Pin Description

Pin Name	Pin No.	Description
U _{IN1} , U _{IN2} V _{IN1} , V _{IN2} W _{IN1} , W _{IN2}	3, 4 1, 2 29, 30	U phase hall element input pin. 'H' of logic : V _{IN1} > V _{IN2} V phase hall element input pin. 'H' of logic : V _{IN1} > V _{IN2} W phase hall element input pin. 'H' of logic : V _{IN1} > V _{IN2}
U _{OUT} V _{OUT} W _{OUT}	11 12 13	U phase output pin V phase output pin W phase output pin
V _{CC1}	10	Power supply pin for applying output
V _{CC2}	16	Power supply pin for applying voltage to each section other than output section. This voltage must be stabilized to be free from ripple, noise, etc.
R _f	14	Output current detect pin. By connecting R _f across this pin and GND pin, output current is detected as voltage. The result is used to control the overcurrent protection circuit.
CD	26	Pin for fetching current (voltage) detected with R _f . Takes feedback from R _f to reduce output voltage gain. Ground when not in use.
FC	5	Frequency characteristic correction
V _C	25	Speed-phase control pin Control is of voltage-controlled type that controls output voltage.
V _{CREF}	21	Control reference voltage
GND	6	GND for other than output Minimum potential of output transistor is at R _f pin.
F/R _C	27	Forward/reverse control pin By setting this pin to 'H' (more than 2.0V)/'L' (less than 0.3V), truth value is changed to perform forward/reverse rotation.
FG _{in-} , FG _{in+}	17, 18	FG signal input pin
FG _{OUT}	19	FG amp output pin
CR	20	This pin voltage can be used to change the hall input-output gain. Connection of an external resistor and capacitor makes it possible to detect the rotational speed of a motor and change the hall input gain in two steps.

Truth Table

	Source	Sink	Input			Forward/Reverse Control F/R _C
			U	V	W	
1	W phase → V phase		H	H	L	L
	V phase → W phase		H	H	L	H
2	W phase → U phase		H	L	L	L
	U phase → W phase		H	L	L	H
3	V phase → W phase		L	L	H	L
	W phase → V phase		L	L	H	H
4	U phase → V phase		L	H	L	L
	V phase → U phase		L	H	L	H
5	V phase → U phase		H	L	H	L
	U phase → V phase		H	L	H	H
6	U phase → W phase		L	H	H	L
	W phase → U phase		L	H	H	H

Input:

H: High level. One of the inputs should have a potential at least 0.2V higher than the other.

L: Low level. One of the inputs should have a potential at least 0.2V lower than the other.

Forward/reverse control:

H: 2.0 to V_{CC2}

L: 0 to 0.3V